

Distributed by:



www.Jameco.com ♦ 1-800-831-4242

The content and copyrights of the attached material are the property of its owner.

Accelerometers

GENERAL PURPOSE, LP SERIES

- ▼ High Performance, 1-Axis and 3-Axis Accelerometers
- ▼ Small, Low-Cost
- ▼ Reliable Packaging with Screw-Down Mounting
- ▼ Factory Calibrated



Applications

- ▼ Automotive Testing
- ▼ Instrumentation
- ▼ Equipment Monitoring

LP Series

The LP Series accelerometers are low cost, general purpose, linear acceleration and/or vibration sensors available in ranges of ± 4 g, ± 10 g, ± 25 g, ± 50 g, and ± 100 g. Common applications are automotive testing, instrumentation, and equipment monitoring. The LP Series sensing element is a silicon micro-machined capacitive beam. The capacitive beam is held in force balance for full scale non-linearity of less than 0.2 %.

The LP Series offers wide dynamic range, has excellent frequency response, operates on a single +5 VDC power supply, and is easy to interface to standard data acquisition systems. The scale factor and the 0 g output level are both ratiometric to the power supply so the accelerometer and any following circuitry will track each other if the supply voltage varies. Alternatively, by specifying the -R option, an unregulated 8-30 V power supply can be used.

Compared to traditional piezoelectric and piezoresistive accelerometer technologies, the silicon micro-machined sensors offer equivalent performance at a significantly lower cost.

The LP Series is offered with a standard 5-pin female connector. The highly flexible, low-mass cable prevents disruption of the measurement.

In addition, Crossbow offers its new **DigiCal** cable and connector option. The **DigiCal** connector allows the user to read the sensor ID, serial number, and calibration information using an I2C bus commonly available on microcontrollers. This new option functions as a TEDS or Transducer Electronic Datasheet, allowing customers to automatically readout the sensor parameters upon power up.

Crossbow recommends its new ACCEL-WIZARD data acquisition system for use with the LP Series and **DigiCal**. The ACCEL-WIZARD data logger and real-time data acquisition system is described on page 25. The ACCEL-WIZARD is a capable high-speed data acquisition system that works with personal computers and laptops via RS-232. The new **DigiCal** LP sensors plug into the ACCEL-WIZARD. ACCEL-WIZARD recognizes the sensors, their measurement range, and calibration data. The ACCEL-WIZARD and LP Series combination allows for turn-key test and measurement that can be set up and configured in a matter of minutes.

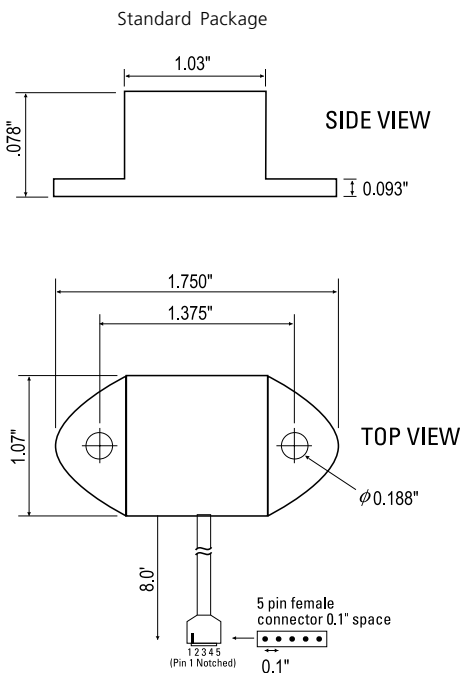

Specifications	CXL04LP1 CXL04LP1Z CXL04LP3	CXL10LP1 CXL10LP1Z CXL10LP3	CXL25LP1 CXL25LP1Z CXL25LP3	CXL50LP1 CXL50LP1Z CXL50LP3	CXL100LP1Z	Remarks
Performance						
Input Range (g)	± 4	± 10	± 25	± 50	± 100	± 5%
Zero g Drift (g)	± 0.2	± 0.2	± 0.2	± 0.2	± 0.2	0°C to 70°C
Sensitivity (mV/g)	500 ± 25	200 ± 10	80 ± 4	40 ± 2	20 ± 4	
Transverse Sensitivity (% Span)	± 5	± 5	± 5	± 5	± 5	
Non-Linearity (% FS)	± 0.2	± 0.2	± 0.2	± 0.2	± 0.2	typical
Alignment Error (deg)	± 2	± 2	± 2	± 2	± 2	typical
Noise (mg rms)	10	10	10	50	80	typical
Bandwidth (Hz)	DC -100	DC -100	DC -100	DC -100	DC -100	
Environment						
Operating Temp. Range (°C)	-40 to +85	-40 to +85	-40 to +85	-40 to +85	-40 to +85	
Shock (g)	2000	2000	2000	2000	2000	
Electrical						
Supply Voltage (Volts)	+ 5.0	+ 5.0	+ 5.0	+ 5.0	+ 5.0	
Supply Voltage -R option (VDC)	+ 8.0 to 30	+ 8.0 to 30	+ 8.0 to 30	+ 8.0 to 30	+ 8.0 to 30	
Supply Current (mA)	5/axis	5/axis	5/axis	5/axis	5/axis	typical
Zero g Output (Volts)	+ 2.5 ± 0.1	+ 2.5 ± 0.1	+ 2.5 ± 0.1	+ 2.5 ± 0.1	+ 2.5 ± 0.1	@25°C
Span Output (Volts)	± 2.0 ± 0.1	± 2.0 ± 0.1	± 2.0 ± 0.1	± 2.0 ± 0.1	± 2.0 ± 0.2	
Output Loading	> 10 kΩ, < 1 nF	> 10 kΩ, < 1 nF	> 10 kΩ, < 1 nF	> 10 kΩ, < 1 nF	> 10 kΩ, < 1 nF	
Physical						
Size	Standard package		0.75" x 1.875" x 1.00 (1.90 cm x 4.76 cm x 2.54 cm)			
	Aluminum package		0.95" x 2.00" x 1.20" (2.41 cm x 5.08 cm x 3.05 cm)			
Weight	Standard package		1.62 oz (46 gm)			
	Aluminum package		2.40 oz (68 gm)			

Notes

Sensitivity is ratiometric to supply: $V_{out} = [Vs/2 + (sensitivity \times Vs/5 \times accel)]$. Zero g Output is ratiometric to supply, proportional to $Vs/2$. Non-linearity is the deviation from a best fit straight line at full scale. Transverse sensitivity is error measured in the primary axis output created by forces induced in the orthogonal axis. Transverse sensitivity error is primarily due to the effects of misalignment (i.e., much of it can be tuned out by adjusting the package orientation or mathematical compensation). Zero g drift is specified as the typical change in 0 g level from its initial value at +25°C to its worst case value at T_{min} or T_{max} . Specifications subject to change without notice.

Pin	Color	Function
1	Red	Power In
2	Black	Ground
3	White	X-axis Out
4	Yellow	Y-axis Out
5	Green	Z-axis Out

Pin Diagram (w/o DigiCal)

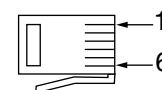
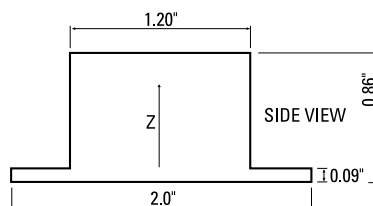
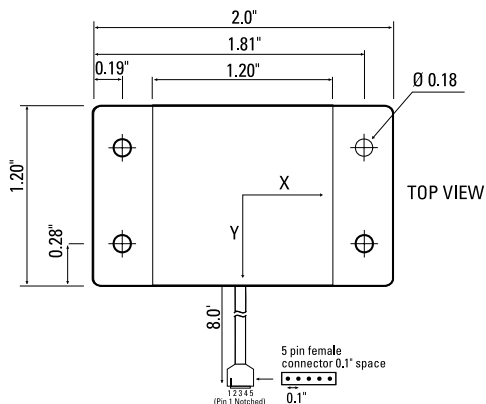

DigCal Connector (Right Hand British-Telcom)

High Temperature Package



Ordering Information

Model	Axes	Span (g)	Sensitivity (mV/g)	Noise (mg rms)	Bandwidth (Hz)
CXL04LP1	X	± 4	500	10	DC-100
CXL04LP1Z	Z	± 4	500	10	DC-100
CXL04LP3	TRI	± 4	500	10	DC-100
CXL10LP1	X	± 10	200	10	DC-100
CXL10LP1Z	Z	± 10	200	10	DC-100
CXL10LP3	TRI	± 10	200	10	DC-100
CXL25LP1	X	± 25	80	10	DC-100
CXL25LP1Z	Z	± 25	80	10	DC-100
CXL25LP3	TRI	± 25	80	10	DC-100
CXL50LP1	X	± 50	40	50	DC-100
CXL50LP1Z	Z	± 50	40	50	DC-100
CXL50LP3	TRI	± 50	40	50	DC-100
CXL100LP1Z	Z	± 100	20	80	DC-100
OPTIONS					
-R	Voltage Regulator, 8 – 30 VDC input (not available with DigiCal)				
-AL	High Temperature Package (see package drawing above)				
-D	Digital Calibration EEPROM (DigiCal)				