

Distributed by:



www.Jameco.com ♦ 1-800-831-4242

The content and copyrights of the attached material are the property of its owner.

SNAP-IN INSULATED SHAFT SERIES METAL SHAFT SERIES/SPECIAL USE SERIES CODE EXPLANATION

RV 09 A 1 — 10 01 — 20 F P — B 5K — X X 9999
1 2 3 4 5 6 7 8 9 10 11 12 13 14

1. Product Line Ex :
RV— Rotary Potentiometer

2. Model

3. Structure Difference :

Type	Difference
T、R	With Tap

4. Derivatives

5. Type of Terminal

Code	Type of Terminal
10	Solder lug
20	PC board (horizontal)
30	PC board (vertical);front
40	PC board (vertical);back

6. Type of Bushing

7. Shaft Length

8. Type of Shaft

9. Axis Angle of F-type Shaft

10. Pattern of Resistance Curve

11. Resistance Value

12. Materials & Methods for Manufacturing Shaft & Bushing

13. Number of Click :

Code	Specification
O	None
C	Center Click
D	11 Positions click
E	21 Positions click
F	41 Positions click

14. Serial No .

訂單指定事項 :

開立訂單時，用途請依下表記載予以指定製品之規格詳細記載並確認之。

項目 :

1. 型號。
2. 公稱阻值及線性要求。
3. 軸型及長度。
4. 端子型式。
5. 段點的有無。
6. 中間抽頭的有無。
7. 音量用或其它。
8. 手焊錫或錫爐焊錫。











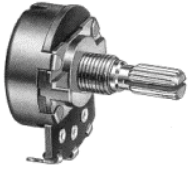
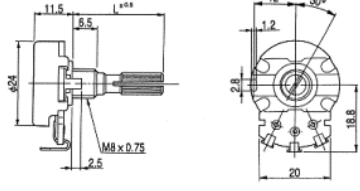

ORDERING INSTRUCTIONS

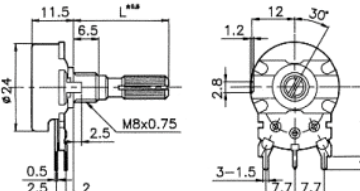
WHEN PLACING YOUR ORDER, PLEASE SPECIFY THE FOLLOWING ITEMS ACCORDING TO YOUR APPLICATION NEEDS. FOR MORE INFORMATION ABOUT OUR PRODUCTS, PLEASE REFER TO THE SPECIFICATIONS GIVEN ON THE FOLLOWING PAGES.

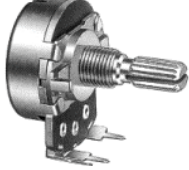
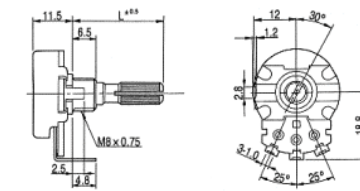
ITEMS :

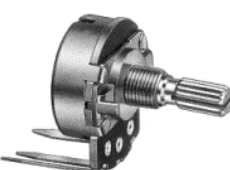
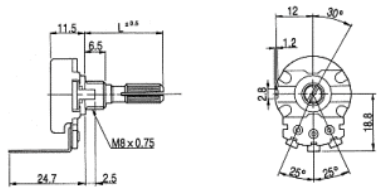
1. MODEL.
2. NORMAL RESISTANCE VALUE AND TAPER.
3. SHAFT STYLE AND LENGTH.
4. TERMINAL STYLE.
5. WITH CLICK OR WITHOUT CLICK, CLICK POSITION.
6. WITH TAP OR WITHOUT TAP, TAP POSITION.
7. FOR VOLUME CONTROL OR OTHER USE.
8. MANUAL SOLDERING OR DIP SOLDERING.

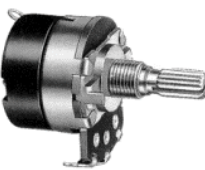
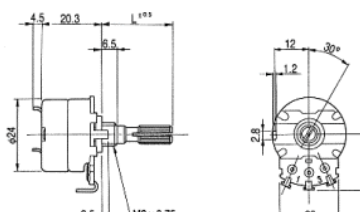
24mm SIZE METAL SHAFT SERIES

Model	Outline Drawing	Features / Individual Specifications
RV24A-10 	 <p style="text-align: center;">SHAFT SHOWN IN FULL C.C.W. POSITION</p>	 <p>300° rotation, single unit</p> 
RV24A-22 	 <p style="text-align: center;">SHAFT SHOWN IN FULL C.C.W. POSITION</p>	 <p>300° rotation, single unit</p> 
RV24A-30 	 <p style="text-align: center;">SHAFT SHOWN IN FULL C.C.W. POSITION</p>	 <p>300° rotation, single unit</p> 
RV24A-40 	 <p style="text-align: center;">SHAFT SHOWN IN FULL C.C.W. POSITION</p>	 <p>300° rotation, single unit</p> 
RV24A01-10 RV24A02-10 	 <p style="text-align: center;">SHAFT SHOWN IN FULL C.C.W. POSITION</p>	 <p>300° rotation, single unit with Rotary SW. S.P.S.T. 125VAC. 1A S.P.D.T. 125VAC. 1A</p> 

12mm,16mm, 17mm, 24mm METAL SHAFT SERIES

Standard Shaft, Bushing, Nut and Washer Dimensions

METAL SHAFT

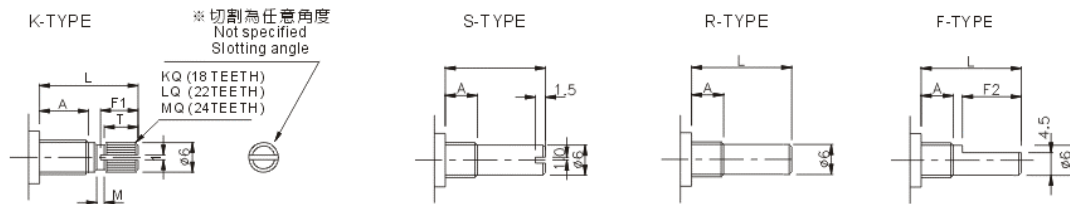

A : 5 m/m

Shaft-Type	L	10	15	20	25	30	35	40
K	F1	3.5	6.5	11	14	14	14	14
	T	3.2	6	10	12	12	12	12
	M	0.5	1	2	4	4	4	4
F	F2	4	7	12	14	14	14	14
R, S	L	10	15	20	25	30	35	40

A : 6.5 m/m

Shaft-Type	L	10	15	20	25	30	35	40
K	F1	2.4	6.5	11	14	14	14	14
	T	2.2	6	10	12	12	12	12
	M	0.5	1	2	4	4	4	4
F	F2	2.5	7	12	14	14	14	14
R, S	L	10	15	20	25	30	35	40

BUSHING

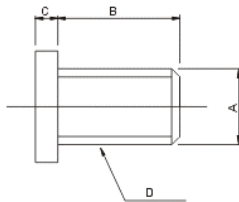

Series	RV24A	RV170	RV160	RV060	RV123	RV120	RV122
A	φ8	φ7	φ7	φ9	φ7	φ7	φ9
B	6.5	5	6.5	7	5	7	8
C	2	1	1.4	0.7	0.5	3.3	—
D	M8x0.75	M7x0.75	M7x0.75	M9x0.75	M7x0.75	M7x0.75	M9x0.75

NUT, WASHER

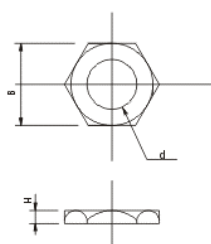



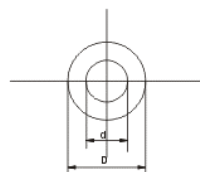









d	B	H
M6x0.75	8	1.8
M7x0.75	10	1.8
M8x0.75	11	1.8
M9x0.75	12	2
M10x0.75	14	2.2
3/8" 32NEF	12.6	2.3















Series	d	D	t
M6	φ6.1	φ10	0.4
M7	φ7.1	φ12	0.4
M8	φ8.1	φ14	0.4
M9	φ9.1	φ14	0.4
M10	φ10.2	φ14.8	0.5
3/8" 32NEF	φ9.7	φ16	0.4

AXIS ANGLE OF F-TYPE SHAFT

Standard Angle (for 300° rotation)

AXIS Angle	Symbol
	F00, (O)
 105°	F01, (A)
 120°	F02, (B)
 135°	F03, (C)
 150°	F04, (D)
 165°	F05, (E)
	F06, (F)
 15°	F07, (G)
 30°	F08, (H)
 45°	F09, (J)
 60°	F10, (K)
 75°	F11, (L)

AXIS Angle	Symbol
	F12, (M)
 105°	F13, (N)
 120°	F14, (P)
 135°	F15, (Q)
 150°	F16, (R)
 165°	F17, (S)
	F18, (T)
 15°	F19, (V)
 30°	F20, (W)
 45°	F21, (X)
 60°	F22, (Y)
 75°	F23, (Z)

Axis angle is shown in full C.C.W. Position

ROTARY POTENTIOMETERS

電氣的性能 Electrical characteristics

項目 Items	嵌入式絕緣軸 Snap-In Insulated Shaft Potentiometers							
	9mm size		11mm size		14mm size			
	單連 Single unit	雙連 Dual unit	單連 Single unit	雙連 Dual unit For high-cut tone	雙連 Dual unit			
殘留阻抗 Residual resistance	$R \leq 1K\Omega$ $1K\Omega < R \leq 50K\Omega$ $50K\Omega < R \leq 100K\Omega$ $100K\Omega < R \leq 500K\Omega$ $500K\Omega < R \leq 1M\Omega$	30Ω Max. 100Ω Max. 300Ω Max. 500Ω Max. $1K\Omega$ Max.	$R \leq 10K\Omega$ $10K\Omega < R < 50K\Omega$ $50K\Omega \leq R \leq 500K\Omega$ of total resistance	20Ω Max. 30Ω Max.	$R \leq 1K\Omega$ $5K\Omega \leq R \leq 50K\Omega$ $50K\Omega < R \leq 100K\Omega$ $100K\Omega < R \leq 250K\Omega$ $250K\Omega < R \leq 500K\Omega$	30Ω Max. 100Ω 200Ω 500Ω $1K\Omega$	$R \leq 30K\Omega$ $30K < R \leq 500K\Omega$ of total resistance	30Ω Max. 0.1% Max.

電氣的性能 Electrical characteristics

項目 Items	嵌入式絕緣軸 Snap-In Insulated Shaft Potentiometers	
	12型 12mm size	16型 16mm size
殘留阻抗 Residual resistance	$R \leq 30K\Omega$ $30K\Omega < R \leq 500K\Omega$	40Ω Max. 0.1% Max. to total resistance

電氣的性能 Electrical characteristics 金屬軸共通規格

項目 Items	9型 9mm size	12型 12mm size	16型, 24型 16mm size, 24mm size	40型 40mm size	
殘留阻抗 Residual resistance	300° 迴轉 300° rotation	$R \leq 10K\Omega$ 20Ω Max. $10K\Omega < R < 50K\Omega$ 30Ω Max. $50K\Omega \leq R$ 全阻抗值 0.1% 以下 $50K\Omega \leq R$, 0.1% Max. of total resistance	3Ω Max.	$R \leq 10K\Omega$ 20Ω Max. $10K\Omega < R < 50K\Omega$ 30Ω Max. $50K\Omega < R$ 全阻抗值 公稱全阻抗值 0.1% 以下 0.1% or less of normal total resistance	3Ω Max.
	120° 迴轉 120° rotation	$R \leq 10K\Omega$ 30Ω Max. $10K\Omega < R$ 全阻抗值 0.2% 以下 $10K\Omega < R$, 0.2% Max. of total resistance	20Ω Max.		

ROTARY POTENTIOMETERS

機械的性能 Mechanical characteristics

	絕緣軸 Insulated Shaft			金屬軸 Metal Shaft			
	9型 9mm size		9型金屬軸 9mm size	12型金屬軸 12mm size	16型 16mm size		
軸、押、拉力強度 Pull-push strength	50N {5kg} Max.	80N {8kg} Max.		100N Max. {10kg} Max.			
軸搖動 Shaft wobble	0.8XL/20mm P-P Max.	Without bushing 0.7 L/20mmp-p Max. 0.7L/30mmp-p以下 With bushing 0.7 L/30mmp-p Max. With 500mg-cm 用500mg-cm	0.6L/20mm P-P Max.	The shaft wobble at the position of 5mm from the top when a load of A gf is applied to said position after mounting the bushing shall be B mm P-P Max.			
				Shaft length (mm)	Thrust A(gf)	Single and outer shafts B(mm P-P)	Inner shaft B(mm P-P)
				15	1000	0.14	—
				20	670	0.2	—
				25	500	0.27	0.4
			30	400	0.34	0.5	

電氣的性能 Electrical characteristics

一般用阻值 Normal total resistance

迴轉型電位器 Rotary potentiometers	
RV09	5K, 10K, 20K, 50K, 100K, 200K
	5K, 10K, 20K, 50K, 100K, 200K
RV12	5K, 10K, 20K, 50K, 100K, 200K, 500K
	5K, 10K, 20K, 50K, 100K, 200K, 500K
RV16,17,24	1K, 5K, 10K, 50K, 100K, 200K, 500K, 1M
	5K, 10K, 20K, 50K, 100K, 200K, 500K, 1M

僅供使用參考
This page is for your reference only.

Resistance taper standards

Taper	Effective rotation angle / Effective travel			
	20%	50%	60%	80%
A		10-25		
B		40-60		
C		10-25		
D		2-15		
E		19-33		
RD		2-15		
W	1-7	40-60		93-99

Across Terminal 1-2 A, B, D, K, W
Across Terminal 2-3 C, E, R, D