

Re: 153277

HALL EFFECT IC APPLICATIONS GUIDE

Cosmo Electric Corporation uses the latest bipolar integrated circuit technology in combination with the century-old Hall Effect to produce Hall Effect ICs. These are contactless, magnetically activated switches and sensors with the potential to simplify and improve systems.

Low-Cost Simplified Switching

Simplified switching is a Hall sensor's strong point. Cosmo Hall Effect IC switches combine Hall voltage generators, signal amplifiers, Schmitt trigger circuits, and transistor output circuits on single integrated circuit chips. Out put is clean, fast, and switched without bounce - an inherent problem with mechanical contact switches. A Cosmo Hall Effect switch typically operates at up to a 100 kHz repetition rate, and costs less than many common electromechanical switches.

The Cosmo Digital Hall Effect sensor detects the motion, position, or change in field strength of an electromagnet, a permanent magnet, or a ferromagnetic material with an applied magnetic bias. Energy consumption is very low. The output is linear and temperature-stable. The sensor's frequency response is flat up to approximately 25 kHz.

A Cosmo Hall Effect sensor is more efficient and effective than inductive or optoelectronic sensors, and at a lower cost.

FUNCTION BLOCK DIAGRAM

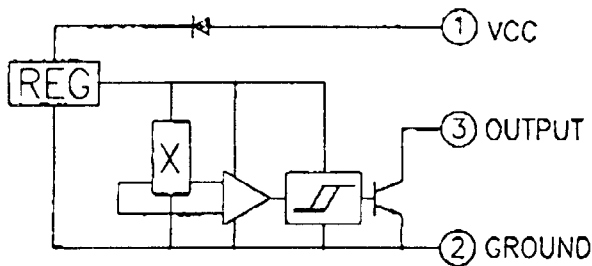

Figure 1

Sensitive Circuits For Rugged Service

The Hall Effect sensor is virtually immune to environmental contaminants and is suitable for use under severe service conditions. The circuit is very sensitive and provides reliable, repetitive operation in close tolerance applications. The Hall Effect sensor can see precisely through dirt and darkness.

Current Applications

Current applications for Cosmo Hall Effect ICs include use in ignition systems, speed controls, security systems, alignment controls, micrometers, mechanical limit switches, computers, printers, disk drives, keyboards, machine tools, key-switches, and push-button switches. They are also used as tachometer pickups, current limit switches, position detectors, selector switches, current sensors, linear potentiometers and brushless DC motor commutators.

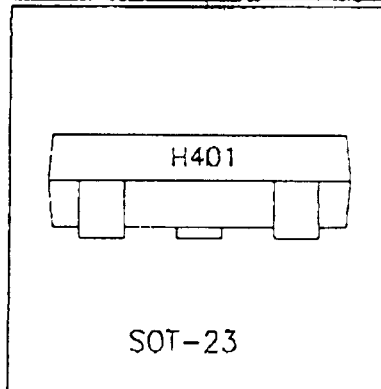
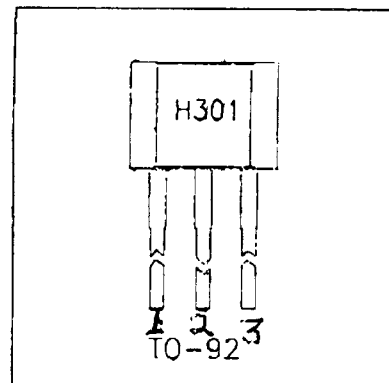

ABSOLUTE MAXIMUM RATINGS at $T_A = +25^\circ\text{C}$

Supply Voltage, V_{CC}	30V
Reverse Battery Voltage, V_{RCC}	-30V
Magnetic Flux Density, B	Unlimited
Output OFF Voltage, V_{OUT}	28V
Reverse Out Put Voltage, V_{OUT}	-0.5V
Continuous Output Current, I_{OUT}	25mA
Operating Temperature Range, T_A	
Suffix 'E'.....	-40 $^\circ\text{C}$ to + 85 $^\circ\text{C}$

Cosmo Hall Effect IC

P/N 153277

■ General Description ITEM NO=H301-A1

Cosmo Electric Corporation uses the latest bipolar integrated circuit technology in combination with the century-old Hall Effect to produce Hall Effect ICs. These are contactless, magnetically activated switches and sensors with the potential to simplify and improve systems.

Though there are many other applications for Cosmo Hall Effect IC, the design, specifications, and performance have been optimized for commutation application in 5V and 24V fans.

The output transistor will be "latched on" in the presence of a sufficiently strong South pole magnetic field facing the marked side of the package. Similarly, the output will be "latched off" in the presence of a North field.

■ Function Block Diagram

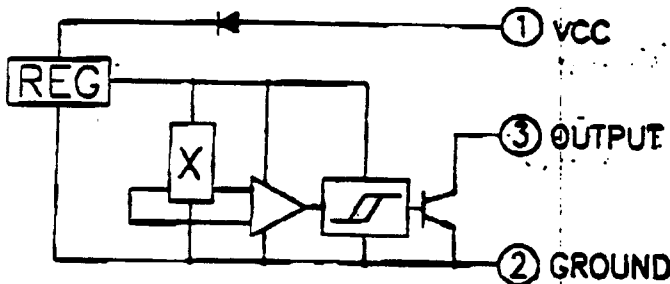

■ Applications

- Fan Motor Commutation
- Brushless DC Motor Commutation
- Speed Sensing
- Current Sensing

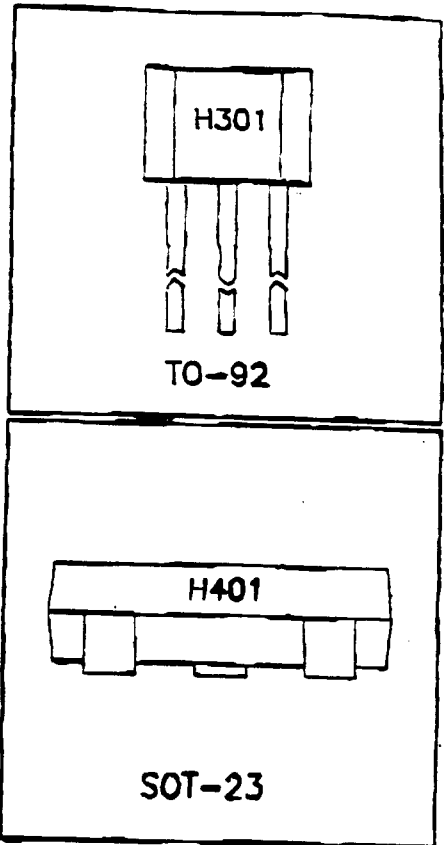

ABSOLUTE MAXIMUM RATINGS at $T_A = +25^\circ\text{C}$.

Supply Voltage, V_{CC}	30V
Reverse Battery Voltage, V_{RCC}	-30V
Magnetic Flux Density, B.....	Unlimited
Output OFF Voltage, V_{OFF}	30V
Reverse Output Voltage, V_{OIT}	-0.5V
Continuous Output Current, I_{OUT}	15mA
Operating Temperature Range, T_A	-40 °C to +85 °C
Storage Temperature Range,	
T_S	-65 °C to +170 °C

Cosmo Hall Effect IC

Absolute Maximum Ratings

(TA=25 °C)

PARAMETER	SYMBOL	RATING	UNITS
SUPPLY VOLTAGE	V _{cc}	30	V
SUPPLY CURRENT	I _{cc}	8	mA
OUTPUT CURRENT	I _{out}	15	mA
POWER DISSIPATION	P _d	100	mW
OPERATING AMBIENT TEMPERATURE	T _a	-30 - +80	°C
STORAGE TEMPERATURE	T _s	-55 - +125	°C
OPERATING SUPPLY VOLTAGE RANGE	V _{cc}	4 - 30	V

Electrical Characteristics

(12VDC AT 25 °C ± 2 °C UNLESS OTHERWISE SPECIFICALLY MENTIONED)

PARAMETER	SYMBOL	TEST CONDITIONS	LIMITS			UNITS
			MIN.	TYP.	MAX.	
SUPPLY VOLTAGE	V _{cc}	OPERATING	4	-	30	V
SUPPLY CURRENT	I _{cc}	OPERATING	4	-	8	mA
SATURATION VOLTAGE	V _{sat}	I _{out} =5mA E>B _{op}	-	-	0.4	V
OUTPUT LEAKAGE	I _{leak}	V _{out} =24v B<B _{rp}	-	0.5	2	µA
OUTPUT RISE TIME	t _r	V _{cc} =12V R ₁ =1.2K C ₁ =20pF	-	0.4	-	µS
OUTPUT FALL TIME	t _f	V _{cc} =12V R ₁ =1.2K C ₁ =20pF	-	0.4	-	µS

Magnetic Specifications At 25 °C 12VDC

RANK	MAXIMUM OPERATE POINT B _{op}	MAXIMUM RELEASE POINT B _{rp}	UNIT
		-70	GAUSS
H301A1	+70	-100	GAUSS
H301A	+100	-150	GAUSS
H301B	+150	-100	GAUSS
H401A	+100	-150	GAUSS
H401B	+150	-150	GAUSS

Cosmo Hall Effect IC

■ *Simensions in Millimeters*

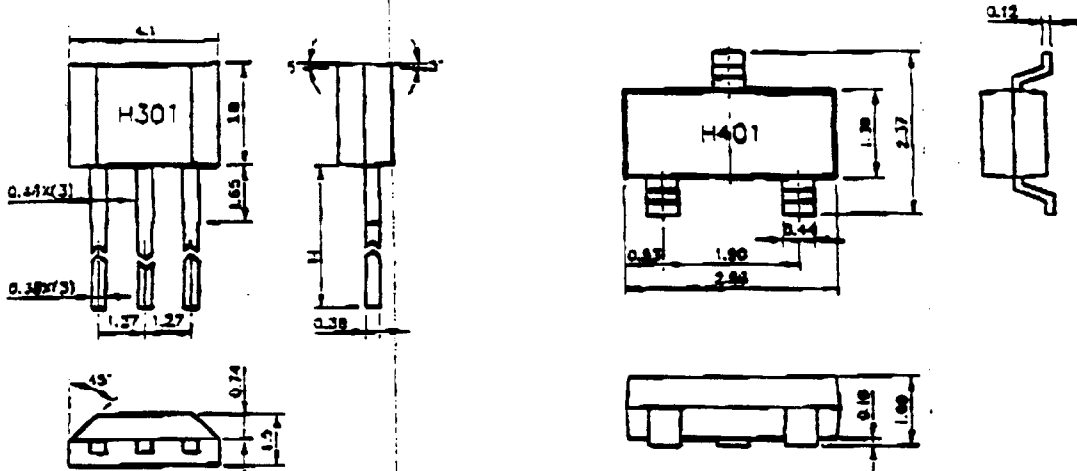

■ *Operational Characteristics*

