

Distributed by:

JAMECO[®]
ELECTRONICS

www.Jameco.com ♦ 1-800-831-4242

The content and copyrights of the attached
material are the property of its owner.

Jameco Part Number 1300161

Wire-to-Wire BMI Connector System

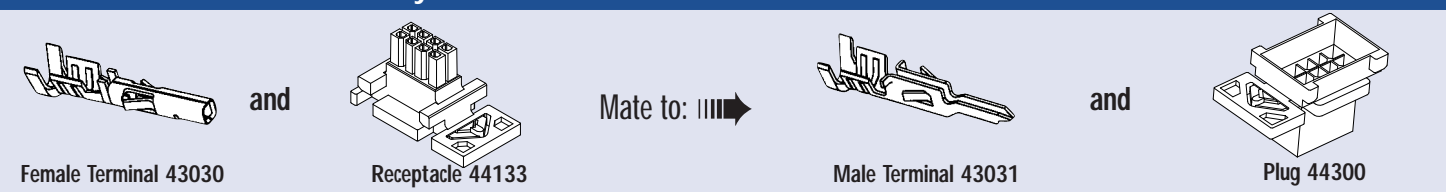

Wire-to-Board BMI Connector System

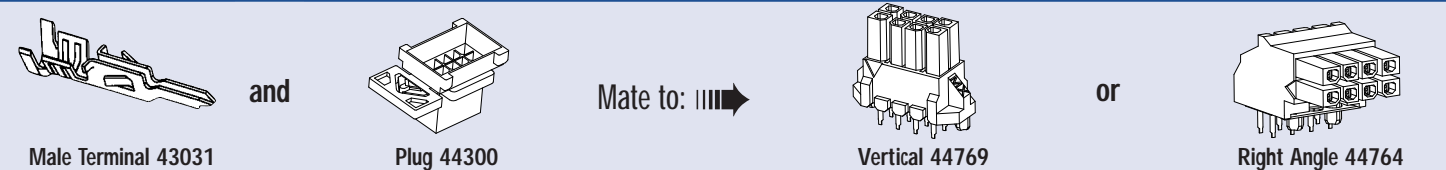

Board-to-Board BMI Connector System

Horizontal Boards

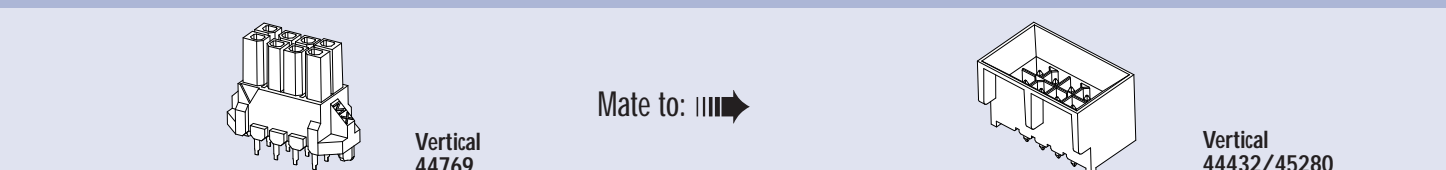

Coplanar Boards

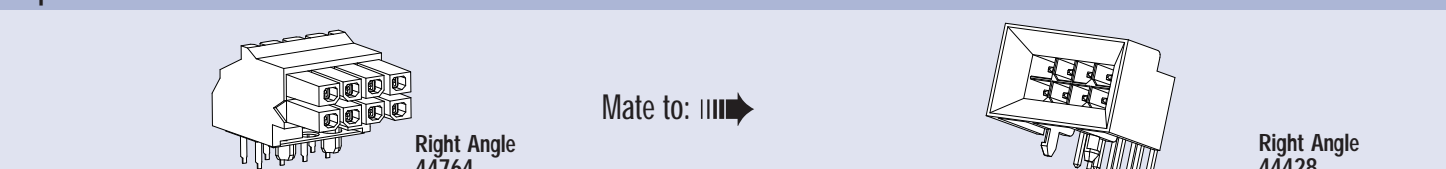

Right Angle Boards

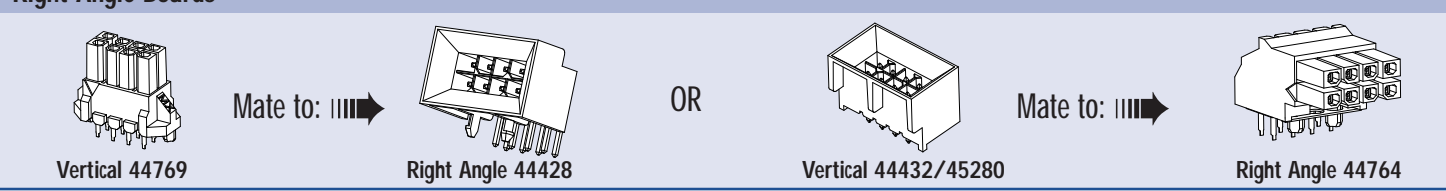

MICRO-FIT 3.0 FAMILY APPLICATION EXAMPLES

- Personal Computers
- Work Stations
- Vending Machines
- Mainframe Computers
- Satellites
- Pin Ball Machines
- Handheld Computers
- Cellular Telephones
- Slot Machines
- Notebook PCs
- AC Power Line Cords
- Exercise Equipment
- Fan Tray Assemblies
- Coffeemakers
- Backplane Applications
- Power Supplies
- Fax Machines

Americas Headquarters
Lisle, Illinois 60532 U.S.A.
Tel: 1-800-78MOLEX
Fax: 630-969-1352

Far East North Headquarters
Yamato, Kanagawa, Japan
Tel: 81-462-65-2324
Fax: 81-462-65-2366

Far East South Headquarters
Jurong, Singapore
Tel: 65-6-268-6868
Fax: 65-6-265-2985

European Headquarters
Munich, Germany
Tel: 49-89-413092-0
Fax: 49-89-401527

Corporate Headquarters
2222 Wellington Ct.
Lisle, IL 60532 U.S.A.
Tel: 630-969-4550
Fax: 630-969-1352

- Fully isolated contacts
- Up to 5.0A per circuit
- Full polarization
- 250V AC rating
- Positive locks
- UL 94V-0, CSA, TUV approved

Crimp Terminals

Description	Order No.		Wire Gauge	Plating
	Reel	Bag		
Female Terminal	43030-0001	43030-0007	20 - 24	Tin
	43030-0004	43030-0010	26 - 30	Tin
	43030-0002	43030-0008	20 - 24	15µ" Gold
	43030-0005	43030-0011	26 - 30	15µ" Gold
	43030-0003	43030-0009	20 - 24	30µ" Gold
	43030-0006	43030-0012	26 - 30	30µ" Gold
Male Terminal	43031-0001	43031-0007	20 - 24	Tin
	43031-0004	43031-0010	26 - 30	Tin
	43031-0002	43031-0008	20 - 24	15µ" Gold
	43031-0005	43031-0011	26 - 30	15µ" Gold
	43031-0003	43031-0009	20 - 24	30µ" Gold
	43031-0006	43031-0012	26 - 30	30µ" Gold

Crimp Housings

Description	Order No.	Material	Description	Order No.	Material
Receptacles (Use with 43030 terminals)			Plugs (Use with 43031 terminals)		
Single Row	43645-XX00	Black Polyester	Single Row, Free Hanging	43640-XX01	Black Polyester
			Single Row, Panel Mount	43640-XX00	Black Polyester
Dual Row	43025-XX00	Black Polyester	Dual Row, Free Hanging	43020-XX01	Black Polyester
			Dual Row, Panel Mount	43020-XX00	Black Polyester

Right Angle Headers

Single Row	Description	Order No.	Plating	Material	Dual Row	Description	Order No.	Plating	Material
Surface Mount Compatible with Pegs		43650-XX00	Tin	High Temperature, Black LCP	Surface Mount Compatible with Pegs		43045-XX00	Tin	High Temperature, Black LCP
		43650-XX01	15µ" Gold				43045-XX01	15µ" Gold	
		43650-XX02	30µ" Gold				43045-XX02	30µ" Gold	
SMT with Solderable Retention Clip		43650-XX09	Tin	High Temperature, Black LCP	SMT with Solderable Retention Clip		43045-XX06	Tin	High Temperature, Black LCP
		43650-XX10	15µ" Gold				43045-XX07	15µ" Gold	
		43650-XX11	30µ" Gold				43045-XX08	30µ" Gold	
SMT with Solder Tabs		43650-XX12	Tin	High Temperature, Black LCP	SMT with Solder Tabs		43045-XX09	Tin	High Temperature, Black LCP
		43650-XX13	15µ" Gold				43045-XX10	15µ" Gold	
		43650-XX14	30µ" Gold				43045-XX11	30µ" Gold	

Vertical Headers

Single Row	Description	Order No.	Plating	Material	Dual Row	Description	Order No.	Plating	Material
Surface Mount Compatible with Pegs		43650-XX15	Tin	High Temperature, Black LCP	Surface Mount Compatible with Pegs		43045-XX12	Tin	High Temperature, Black LCP
		43650-XX16	15µ" Gold				43045-XX13	15µ" Gold	
		43650-XX17	30µ" Gold				43045-XX14	30µ" Gold	
SMT with Solderable Retention Clip		43650-XX21	Tin	High Temperature, Black LCP	SMT with Solderable Retention Clip		43045-XX15	Tin	High Temperature, Black LCP
		43650-XX22	15µ" Gold				43045-XX16	15µ" Gold	
		43650-XX23	30µ" Gold				43045-XX17	30µ" Gold	
SMT with Solder Tabs		43650-XX24	Tin	High Temperature, Black LCP	SMT with Solder Tabs		43045-XX18	Tin	High Temperature, Black LCP
		43650-XX25	15µ" Gold				43045-XX19	15µ" Gold	
		43650-XX26	30µ" Gold				43045-XX20	30µ" Gold	

Replace XX with number of circuits, 02 to 24

MICRO-FIT 3.0

molex 3.00mm (.118") Pitch
Micro-Fit 3.0™ Family

The Micro-Fit 3.0 is a unique connector system that incorporates many of the features previously found only on large power connectors. These connectors are the perfect choice when you need compact connectors that can carry up to 5.0A of current. Micro-Fit 3.0 is available in circuit sizes 2 to 24 for wire-to-board and wire-to-wire applications. With more than 500 part numbers and still growing, this expansive product line offers through hole and SMT options. SMT versions are available in tape and reel packaging for robotic placement on the PCB.

Wire-to-Wire Single Row Connector System



Wire-to-Board Single Row Connector System

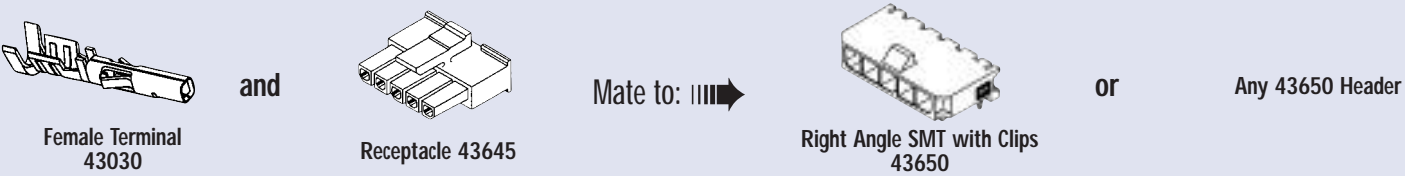

Wire-to-Wire Dual Row Connector System



Wire-to-Board Dual Row Connector System



MICRO-FIT 3.0, CPI AND MICRO-FIT 3.0, BMI CPI

The Micro-Fit 3.0, CPI (Compliant Pin Interface) and Micro-Fit 3.0, BMI CPI (Blind Mate Version with Compliant Pin Interface) are vertical header product extensions featuring press-fit PC tails.

- CPI style (Press-Fit) pins require no soldering to the PCB
- 2.36mm (.093") minimum PCB thickness

Standard CPI

	Description	Order No.	Plating	Material
	Standard Vertical CPI	44914-XX01	Tin	High Temperature, Black LCP
		44914-XX02	12µ" Gold	
		44914-XX03	30µ" Gold	

BMI CPI

	Blind Mate Vertical CPI	45280-XX01	Tin	High Temperature, Black Glass-Filled Nylon
		45280-XX02	12µ" Gold	
		45280-XX03	30µ" Gold	

MICRO-FIT 3.0, BMI

molex 3.00mm (.118") Pitch
Micro-Fit 3.0™ Family

Micro-Fit 3.0, BMI™ (Blind Mate Interface) features an innovative panel mounting design that securely locks the plugs and receptacles in place in the panel cutout, while allowing for removal. The plugs and headers feature a funnel entry to guide the mating receptacle or receptacle header into place. Micro-Fit 3.0, BMI housings and headers mate exclusively with the BMI components shown here.

- Full polarization
- Fully isolated contacts
- Dual row
- Sizes 4 to 24 circuits
- Up to 5.0A per circuit
- Up to 1500V AC dielectric withstand voltage
- UL 94V-0, CSA, TUV approved

Crimp Housings

- Use standard Micro-Fit terminals
- Receptacle floats in panel cutout up to 1.27mm (.050") in any direction
- Can be utilized with BMI board-to-board connectors
- Panel thickness: 1.57mm (.062")

	Description	Order No.	Material
	Panel Mount Receptacle	44133-XX00	Black, Polyester
	Panel Mount Plug	44300-XX00	Black, Polyester

Headers

- Can be utilized with BMI wire-to-wire connectors
- 1.57mm (.062") PCB thickness
- Surface mount compatible (SMC)
- Black, glass filled nylon housings

Right Angle

	Description	Order No.	Plating		Description	Order No.	Plating
	Right Angle Header with Pegs	44428-XX01	Tin		Right Angle Receptacle	44764-XX01	Tin
		44428-XX02	15µ" Gold			44764-XX02	15µ" Gold
		44428-XX03	30µ" Gold			44764-XX03	30µ" Gold

Vertical

	Vertical Header with Pegs	44432-XX01	Tin		Vertical Receptacle	44769-XX01	Tin
		44432-XX02	15µ" Gold			44769-XX02	15µ" Gold
		44432-XX03	30µ" Gold			44769-XX03	30µ" Gold

Replace XX with number of circuits, 04 to 24



PRODUCT SPECIFICATION

MICRO-FIT

1.0 SCOPE

This Product Specification covers the 3.00 mm (.118 inch) centerline (pitch) square pin headers when mated with either printed circuit board (PCB) connector or connectors terminated with 20 to 30 AWG wire using crimp technology.

2.0 PRODUCT DESCRIPTION

2.1 PRODUCT NAME AND SERIES NUMBERS

Receptacle: 43025 Terminal: 43030
Plug: 43020 Terminal: 43031
Headers: 43045, 44914

Test Plug: 44242 (recommended for continuity testing only)

Other products conforming to this specification are noted on the individual drawings.

2.2 DIMENSIONS, MATERIALS, PLATINGS AND MARKINGS

Housings: Polyester or LCP
Terminal: Phosphor Bronze
Pins: Brass, Modified Tin/Brass

2.3 SAFETY AGENCY APPROVALS

UL File Number: E29179
CSA: LR19980
TUV: 72040445

3.0 APPLICABLE DOCUMENTS AND SPECIFICATIONS

Test Summary: TS-43045-001

4.0 RATINGS

4.1 VOLTAGE

UL: 250 Volts AC (MAX) {or 176 Volts DC}
TUV: 250 Volts

4.2 CURRENT AND APPLICABLE WIRES (Current is dependent on connector size, contact material, plating, ambient temperature, printed circuit board characteristics and related factors. Actual current rating is application dependent and should be evaluated for each application.)

AWG	Amps	Max. Outside Insulation Diameter
20	5	1.85 mm (.073 inch)
22	5	1.85 mm (.073 inch)
24	4	1.85 mm (.073 inch)
26	3	1.27 mm (.050 inch)
28	2	1.27 mm (.050 inch)
30	1	1.27 mm (.050 inch)

4.2.1 CURRENT FOR TEST PLUG 44242

2.5 Amps Maximum (Pogo pin current capacity)

(Test plugs are for testing purposes only and not intended for continuous use.)

4.3 TEMPERATURE

Operating: - 40°C to + 105°C (Including Terminal Temperature Rise)
Nonoperating: - 40°C to + 105°

REVISION: L	EGR/ECN INFORMATION: EC No: UCP2007-1024 DATE: 2006/10/24	TITLE: PRODUCT SPECIFICATION MICRO-FIT DUAL ROW CONNECTORS	SHEET No. 1 of 5
DOCUMENT NUMBER: PS-43045		CREATED / REVISED BY: M.KIPPER	CHECKED BY: S.SOUSEK
		APPROVED BY: F.SMITH	



PRODUCT SPECIFICATION

5.0 PERFORMANCE

5.1 ELECTRICAL REQUIREMENTS

DESCRIPTION	TEST CONDITION	REQUIREMENT
Contact Resistance (Low Level)	Mate connectors: apply a maximum voltage of 20 mV and a current of 100 mA. (Does not include wire resistance)	10 milliohms MAXIMUM [initial]
Contact Resistance @ Rated Current	Mate connectors: apply a maximum voltage of 20 mV at rated current.	30 milliohms MAXIMUM [initial]
Contact Resistance of Wire Termination (Low Level)	Terminate the applicable wire to the terminal and measure wire using a voltage of 20 mV and a current of 100 mA.	5 milliohms MAXIMUM [initial]
Insulation Resistance	Unmate & unmount connectors: apply a voltage of 500 VDC between adjacent terminals and between terminals to ground.	1000 Megohms MINIMUM
Dielectric Withstanding Voltage	Unmate connectors: apply a voltage of {two times the rated voltage plus 1000 volts} VAC for 1 minute between adjacent terminals and between terminals to ground.	No breakdown; current leakage < 5 mA
Capacitance	Measure between adjacent terminals at 1 MHz.	2 picofarads MAXIMUM
Temperature Rise (via Current Cycling)	Mate connectors: measure the temperature rise at the rated current after: 1) 96 hours (steady state) 2) 240 hours (45 minutes ON and 15 minutes OFF per hour) 3) 96 hours (steady state)	Temperature rise: +30°C MAXIMUM

5.2 MECHANICAL REQUIREMENTS

DESCRIPTION	TEST CONDITION	REQUIREMENT
Connector Mate and Unmate Forces	Mate and unmate connector (male to female) at a rate of 25 ± 6 mm (1 ± ¼ inch) per minute. (Per circuit)	8.0 N (1.8 lbf) MAXIMUM insertion force & 3.7 N (0.8 lbf) MINIMUM withdrawal force
Terminal Retention Force (in Housing)	Axial pullout force on the terminal in the housing at a rate of 25 ± 6 mm (1 ± ¼ inch) per minute.	24.5 N (5.5 lbf) MINIMUM retention force
Terminal Insertion Force (into Housing)	Apply an axial insertion force on the terminal at a rate of 25 ± 6 mm (1 ± ¼ inch) per minute.	14.7 N (3.3 lbf) MAXIMUM insertion force

REVISION: L	EGR/ECN INFORMATION: EC No: UCP2007-1024 DATE: 2006/10/24	TITLE: PRODUCT SPECIFICATION MICRO-FIT DUAL ROW CONNECTORS	SHEET No. 2 of 5
DOCUMENT NUMBER: PS-43045	CREATED / REVISED BY: M.KIPPER	CHECKED BY: S.SOUSEK	APPROVED BY: F.SMITH



PRODUCT SPECIFICATION

5.2 MECHANICAL REQUIREMENTS

Durability	Mate connectors up to 30 cycles at a maximum rate of 10 cycles per minute prior to Environmental Tests.	20 milliohms MAXIMUM (change from initial)
Vibration (Random)	Mate connectors and vibrate per EIA 364-28, test condition VII.	20 milliohms MAXIMUM (change from initial) & Discontinuity < 1 microsecond
Shock (Mechanical)	Mate connectors and shock at 50 g's with 1/2 sine wave (11 milliseconds) shocks in the ±X,±Y,±Z axes (18 shocks total).	20 milliohms MAXIMUM (change from initial) & Discontinuity < 1 microsecond
Wire Pullout Force (Axial) (Wire from Terminal)	Apply an axial pullout force on the wire at a rate of 25 ± 6 mm (1 ± 1/4 inch) per minute.	MINIMUM pullout force 20 awg: 57.8 N (13.0 lbf) 22 awg: 35.6 N (8.0 lbf) 24 awg: 22.2 N (5.0 lbf) 26 awg: 13.3 N (3.0 lbf) 28 awg: 8.9 N (2.0 lbf) 30 awg: 6.6 N (1.5 lbf)
Normal Force	Apply a perpendicular force.	2.7 N (275 grams) MINIMUM
Pin to Header Retention	Apply axial push force to pin at a rate of 25 ± 6 mm (1 ± 1/4 inch) per minute.	13.7 N (3.1 lbf) MINIMUM pushout force
Thumb Latch to Ramp Yield Strength	Full mate and then Unmate the connectors at a rate of 25 ± 6 mm (1 ± 1/4 inch) per minute.	68.4 N (15.4 lbf) MINIMUM Yield Strength
Panel Mount Retention	Full mate and then Unmate the connectors at a rate of 25 ± 6 mm (1 ± 1/4 inch) per minute.	155.7 N (35 lbf) MINIMUM pushout force
Compliant Pin Insertion Force into PCB Hole (44914 Series)	Apply an axial insertion force on the terminal at a rate of 25 ± 6 mm (1 ± 1/4 inch) per minute.	106.7 N (24 lbf) MAXIMUM Insertion force (Per Terminal)
Compliant Pin Retention Force in PCB Hole (44914 Series)	Apply an axial extraction force on the terminal at a rate of 25 ± 6 mm (1 ± 1/4 inch) per minute.	35.6 N (8 lbf) MINIMUM Retention force (Per Terminal)

REVISION: L	EGR/ECN INFORMATION: EC No: UCP2007-1024 DATE: 2006/10/24	TITLE: PRODUCT SPECIFICATION MICRO-FIT DUAL ROW CONNECTORS	SHEET No. 3 of 5
DOCUMENT NUMBER: PS-43045	CREATED / REVISED BY: M.KIPPER	CHECKED BY: S.SOUSEK	APPROVED BY: F.SMITH



PRODUCT SPECIFICATION

5.3 ENVIRONMENTAL REQUIREMENTS

DESCRIPTION	TEST CONDITION	REQUIREMENT
Thermal Aging	Mate connectors; expose to: 240 hours at 105 ± 2°C OR 500 hours at 85 ± 2°C	20 milliohms MAXIMUM (change from initial)]
Humidity (Steady State)	Mate connectors: expose to a temperature of 40 ± 2°C with a relative humidity of 90-95% for 96 hours. Note: Remove surface moisture and air dry for 1 hour prior to measurements.	20 milliohms MAXIMUM (change from initial) & Dielectric Withstanding Voltage: No Breakdown at 500 VAC & Insulation Resistance: 1000 Megohms MINIMUM
Solderability	Per SMES-152	Solder coverage: 95% MINIMUM (per SMES-152)
Solder Resistance	A) Wave Solder Process Dip connector terminal tails in solder; Solder Duration: 5 ± 0.5 seconds; Solder Temperature: 260°C MAX B) Convection Reflow Solder Process 235°C MAX Per SMES-152	Visual: No Damage to insulator material
Cold Resistance	Mate connectors: Duration: 96 hours; Temperature: -40 ± 3°C	20 milliohms MAXIMUM (change from initial)

6.0 PACKAGING

Parts shall be packaged to protect against damage during handling, transit and storage per the packaging specifications listed below:

Receptacle: PK-43025-001

Plug: PK-43020-001

Headers: PK-70873-0313, PK-70873-0314, PK-70873-05**.

REVISION: L	EGR/ECN INFORMATION: EC No: UCP2007-1024 DATE: 2006/10/24	TITLE: PRODUCT SPECIFICATION MICRO-FIT DUAL ROW CONNECTORS	SHEET No. 4 of 5
DOCUMENT NUMBER: PS-43045		CREATED / REVISED BY: M.KIPPER	CHECKED BY: S.SOUSEK
		APPROVED BY: F.SMITH	



PRODUCT SPECIFICATION

7.0 GAGES AND FIXTURES

It is recommended that test plugs (Series 44242) be used for continuity testing of receptacles. Standard mating parts should not be used for harness testing.

8.0 OTHER INFORMATION

8.1 CABLE TIE AND OR WIRE TWIST LOCATION

CKT Sizes	Dim T	Min.
2-8	.500	(12.70)
10-16	.750	(19.10)
18-24	1.000	(25.40)

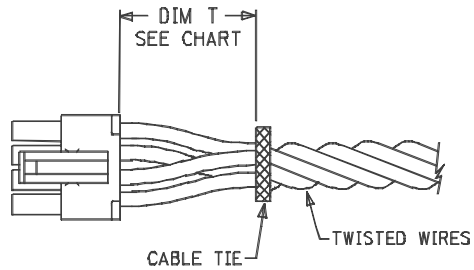

REVISION: L	EGR/ECN INFORMATION: EC No: UCP2007-1024 DATE: 2006/10/24	TITLE: PRODUCT SPECIFICATION MICRO-FIT DUAL ROW CONNECTORS	SHEET No. 5 of 5
DOCUMENT NUMBER: PS-43045	CREATED / REVISED BY: M.KIPPER	CHECKED BY: S.SOUSEK	APPROVED BY: F.SMITH

13 12 11 10 9 8 7 6 5 4 3 2 43045

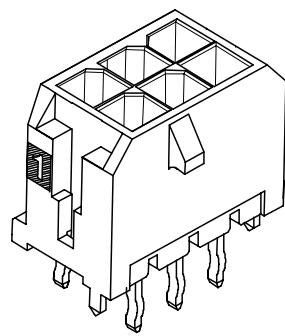
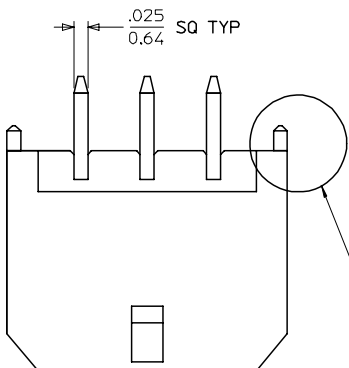

NOTE : (2) POLARIZATION PEGS ARE SHOWN. HOWEVER, ASSEMBLIES MAY BE MANUFACTURED WITH (1) PEG ONLY.

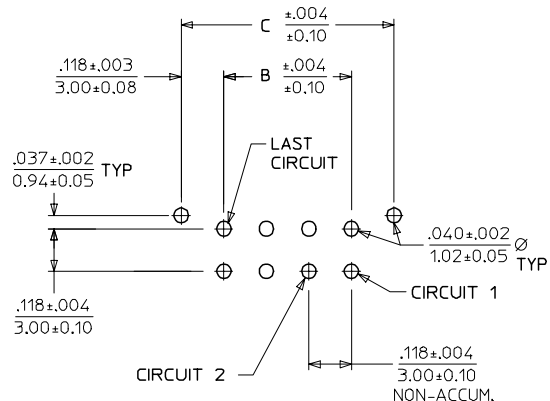

PCB LAYOUT: COMPONENT SIDE
RECOMMEND PCB THICKNESS: .062/157

CKTS	A	B	C
02	.262 6.65	NA	.236 6.00
04	.380 9.65	.118 3.00	.354 9.00
06	.498 12.65	.236 6.00	.472 12.00
08	.616 15.65	.354 9.00	.591 15.00
10	.734 18.65	.472 12.00	.709 18.00
12	.852 21.65	.591 15.00	.827 21.00
14	.970 24.65	.709 18.00	.945 24.00
16	1.088 27.65	.827 21.00	1.063 27.00
18	1.206 30.65	.945 24.00	1.181 30.00
20	1.325 33.65	1.063 27.00	1.299 33.00
22	1.443 36.65	1.181 30.00	1.417 36.00
24	1.561 39.65	1.299 33.00	1.535 39.00

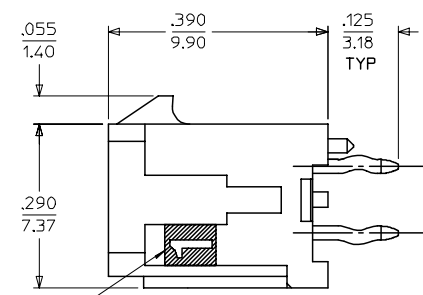
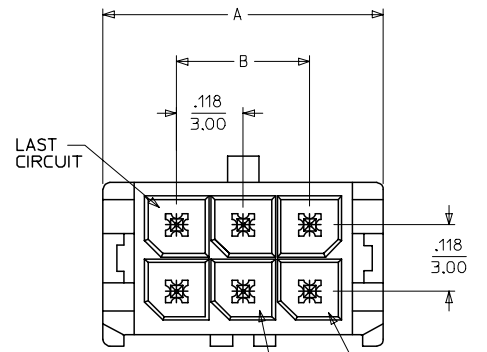

CIRCUIT "1" IDENTIFIED ON THIS SURFACE (APPROX. LOCATION SHOWN FOR REF.)

NOTES:

- HOUSING MATERIAL: GLASS FILLED LIQUID CRYSTAL POLYMER, UL94V-0. COLOR: BLACK
TERMINAL MATERIAL: BRASS ALLOY
- FINISH:
A = .000100/(0.00254) MIN. TIN OVER
.000050/(0.00127) MIN. NICKEL PLATE.
B = .000015/(0.00038) MIN. SELECT GOLD IN CONTACT AREA,
.000100/(0.00254) MIN. SELECT TIN ON SOLDER TAILS;
BOTH OVER .000050/(0.00127) MIN. NICKEL PLATE.
C = .000030/(0.00076) MIN. SELECT GOLD IN CONTACT AREA,
.000100/(0.00254) MIN. SELECT TIN ON SOLDER TAILS;
BOTH OVER .000050/(0.00127) MIN. NICKEL PLATE.
- * THE PRIMARY SHIPPING CARTON WILL BE LABELED "COMPLIANT TO RoHS DIRECTIVE 2002/95/EC AND ELV ANNEX II OF DIRECTIVE 2000/53/EC." CARTONS WITHOUT THIS LABEL MAY CONTAIN PRODUCT WITH TIN/LEAD IN THE PC TAIL AREA.
- PRODUCT SPECIFICATION: PS-43045
- MATES WITH MICRO FIT (3.0) RECEPTACLE SERIES 43025
- TRAY PACKAGED: SEE MOLEX DRAWING PK-70873-0314

	FINISH A	FINISH B	FINISH C
CKTS	MATERIAL NO:	MATERIAL NO:	MATERIAL NO:
02	43045-0212	43045-0213	43045-0214
04	43045-0412	43045-0413	43045-0414
06	43045-0612	43045-0613	43045-0614
08	43045-0812	43045-0813	43045-0814
10	43045-1012	43045-1013	43045-1014
12	43045-1212	43045-1213	43045-1214
14	43045-1412	43045-1413	43045-1414
16	43045-1612	43045-1613	43045-1614
18	43045-1812	43045-1813	43045-1814
20	43045-2012	43045-2013	43045-2014
22	43045-2212	43045-2213	43045-2214
24	43045-2412	43045-2413	43045-2414

CHANGED "1" LOCATION FC NO: UCP2006-1962 DRAWN:PRDIER 2006/03/30 CHKD:SSOUSEK 2006/03/31 APPR:FSMITH 2006/04/03	QUALITY SYMBOLS	GENERAL TOLERANCES (UNLESS SPECIFIED)	SCALE ---	DESIGN UNITS METRIC	THIRD ANGLE PROJECTION	REVISE ON CAD ONLY	
	DESCRIPTION ▽ - 0 ▽ - 0	4 PLACES ± --- ± ---	mm INCH	DIMENSION STYLE IN/MM		DRAWN BY DATE SAMIEC 2000/03/15 CHECKED BY DATE MUELLER 2000/03/15 APPROVED BY DATE EDGLEY 2000/03/15	TITLE MICRO FIT (3.0) DUAL ROW VERTICAL THRU HOLE HEADER ASS'Y molex MOLEX INCORPORATED
		3 PLACES ± --- ± .010					
		2 PLACES ± 0.25 ± .014					
1 PLACE ± 0.36 ± ---							
	ANGULAR ±1/2°	DRAFT WHERE APPLICABLE MUST REMAIN WITHIN DIMENSIONS		MATERIAL NO. DOCUMENT NO. SHEET NO.			
				SD-43045-005 1 OF			
				THIS DRAWING CONTAINS INFORMATION THAT IS PROPRIETARY TO MOLEX INCORPORATED AND SHOULD NOT BE USED WITHOUT WRITTEN PERMISSION			

12 11 10 9 8 7 6 5 4 3 2 1