

Distributed by:

**JAMECO**<sup>®</sup>  
ELECTRONICS

**www.Jameco.com ♦ 1-800-831-4242**

The content and copyrights of the attached  
material are the property of its owner.

Jameco Part Number 1847844

# 1-Kb, 2-Kb and 4-Kb SPI Serial CMOS EEPROM



## FEATURES

- 10 MHz SPI compatible
- 1.8V to 5.5V supply voltage range
- SPI modes (0,0) & (1,1)
- 16-byte page write buffer
- Self-timed write cycle
- Hardware and software protection
- Block write protection
  - Protect 1/4, 1/2 or entire EEPROM array
- Low power CMOS technology
- 1,000,000 program/erase cycles
- 100 year data retention
- Industrial and Extended temperature range
- RoHS-compliant 8-lead PDIP, SOIC, TSSOP and 8-pad TDFN packages

## DESCRIPTION

The CAT25010/20/40 are 1-Kb/2-Kb/4-Kb Serial CMOS EEPROM devices internally organized as 128x8/256x8/512x8 bits. They feature a 16-byte page write buffer and support the Serial Peripheral Interface (SPI) protocol. The device is enabled through a Chip Select ( $\overline{CS}$ ) input. In addition, the required bus signals are a clock input (SCK), data input (SI) and data output (SO) lines. The  $\overline{HOLD}$  input may be used to pause any serial communication with the CAT25010/20/40 device. These devices feature software and hardware write protection, including partial as well as full array protection.



## PIN CONFIGURATION

	PDIP (L)		
	SOIC (V)		
	TSSOP (Y)		
	TDFN (VP2)		
$\overline{CS}$	1	8	$V_{CC}$
SO	2	7	$\overline{HOLD}$
$\overline{WP}$	3	6	SCK
$V_{SS}$	4	5	SI

## PIN FUNCTION

Pin Name	Function
$\overline{CS}$	Chip Select
SO	Serial Data Output
$\overline{WP}$	Write Protect
$V_{SS}$	Ground
SI	Serial Data Input
SCK	Serial Clock
$\overline{HOLD}$	Hold Transmission Input
$V_{CC}$	Power Supply

## FUNCTIONAL SYMBOL

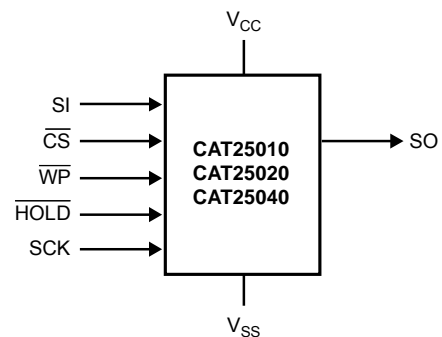

For Ordering Information details, see page 16.

**ABSOLUTE MAXIMUM RATINGS<sup>(1)</sup>**

Parameters	Ratings	Units
Storage Temperature	-65 to +150	°C
Voltage on any Pin with Respect to Ground <sup>(2)</sup>	-0.5 to $V_{CC} + 0.5$	V

**RELIABILITY CHARACTERISTICS<sup>(3)</sup>**

Symbol	Parameter	Min	Units
$N_{END}$ <sup>(4)</sup>	Endurance	1,000,000	Program/ Erase Cycles
$T_{DR}$	Data Retention	100	Years

**D.C. OPERATING CHARACTERISTICS**

$V_{CC} = +1.8V$  to  $+5.5V$ ,  $T_A = -40^\circ C$  to  $+125^\circ C$  unless otherwise specified.

Symbol	Parameter	Test Conditions	Min	Max	Units	
$I_{CC}$	Supply Current	Read, Write, $V_{CC} = 5.0V$ , SO open	10MHz / $-40^\circ C$ to $85^\circ C$	2	mA	
			5MHz / $-40^\circ C$ to $125^\circ C$	2	mA	
$I_{SB1}$	Standby Current	$V_{IN} = GND$ or $V_{CC}$ , $\overline{CS} = V_{CC}$ , $\overline{WP} = V_{CC}$ , $V_{CC} = 5.0V$		2	$\mu A$	
$I_{SB2}$	Standby Current	$V_{IN} = GND$ or $V_{CC}$ , $\overline{CS} = V_{CC}$ , $\overline{WP} = GND$ , $V_{CC} = 5.0V$	$T_A = -40^\circ C$ to $+85^\circ C$	4	$\mu A$	
			$T_A = -40^\circ C$ to $+125^\circ C$	5	$\mu A$	
$I_L$	Input Leakage Current	$V_{IN} = GND$ or $V_{CC}$	-2	2	$\mu A$	
$I_{LO}$	Output Leakage Current	$\overline{CS} = V_{CC}$ , $V_{OUT} = GND$ or $V_{CC}$	$T_A = -40^\circ C$ to $+85^\circ C$	-1	1	$\mu A$
			$T_A = -40^\circ C$ to $+125^\circ C$	-1	2	$\mu A$
$V_{IL}$	Input Low Voltage		-0.5	$0.3V_{CC}$	V	
$V_{IH}$	Input High Voltage		$0.7V_{CC}$	$V_{CC} + 0.5$	V	
$V_{OL1}$	Output Low Voltage	$V_{CC} > 2.5V$ , $I_{OL} = 3.0mA$		0.4	V	
$V_{OH1}$	Output High Voltage	$V_{CC} > 2.5V$ , $I_{OH} = -1.6mA$	$V_{CC} - 0.8V$		V	
$V_{OL2}$	Output Low Voltage	$V_{CC} > 1.8V$ , $I_{OL} = 150\mu A$		0.2	V	
$V_{OH2}$	Output High Voltage	$V_{CC} > 1.8V$ , $I_{OH} = -100\mu A$	$V_{CC} - 0.2V$		V	

**PIN CAPACITANCE<sup>(3)</sup>**

$T_A = 25^\circ C$ ,  $f = 1.0MHz$ ,  $V_{CC} = +5.0V$

Symbol	Test	Conditions	Min	Typ	Max	Units
$C_{OUT}$	Output Capacitance (SO)	$V_{OUT} = 0V$			8	pF
$C_{IN}$	Input Capacitance ( $\overline{CS}$ , SCK, SI, $\overline{WP}$ , HOLD)	$V_{IN} = 0V$			8	pF

**Notes:**

- (1) Stresses above those listed under "Absolute Maximum Ratings" may cause permanent damage to the device. These are stress ratings only, and functional operation of the device at these or any other conditions outside of those listed in the operational sections of this specification is not implied. Exposure to any absolute maximum rating for extended periods may affect device performance and reliability.
- (2) The DC input voltage on any pin should not be lower than  $-0.5V$  or higher than  $V_{CC} + 0.5V$ . During transitions, the voltage on any pin may undershoot to no less than  $-1.5V$  or overshoot to no more than  $V_{CC} + 1.5V$ , for periods of less than 20ns.
- (3) These parameters are tested initially and after a design or process change that affects the parameter according to appropriate AEC-Q100 and JEDEC test methods.
- (4) Page Mode,  $V_{CC} = 5V$ ,  $25^\circ C$

**A.C. CHARACTERISTICS**
 $T_A = -40^{\circ}\text{C}$  to  $+125^{\circ}\text{C}$ , unless otherwise specified.<sup>(1)</sup>

Symbol	Parameter	$V_{CC} = 1.8\text{V}-5.5\text{V}$		$V_{CC} = 2.5\text{V}-5.5\text{V}$ $T_A = -40^{\circ}\text{C}$ to $+85^{\circ}\text{C}$		Units
		Min.	Max.	Min.	Max.	
$f_{\text{SCK}}$	Clock Frequency	DC	5	DC	10	MHz
$t_{\text{SU}}$	Data Setup Time	30		20		ns
$t_{\text{H}}$	Data Hold Time	30		20		ns
$t_{\text{WH}}$	SCK High Time	75		40		ns
$t_{\text{WL}}$	SCK Low Time	75		40		ns
$t_{\text{LZ}}$	$\overline{\text{HOLD}}$ to Output Low Z		50		25	ns
$t_{\text{RI}}^{(2)}$	Input Rise Time		2		2	$\mu\text{s}$
$t_{\text{FI}}^{(2)}$	Input Fall Time		2		2	$\mu\text{s}$
$t_{\text{HD}}$	$\overline{\text{HOLD}}$ Setup Time	0		0		ns
$t_{\text{CD}}$	$\overline{\text{HOLD}}$ Hold Time	10		10		ns
$t_{\text{V}}$	Output Valid from Clock Low		75		40	ns
$t_{\text{HO}}$	Output Hold Time	0		0		ns
$t_{\text{DIS}}$	Output Disable Time		50		20	ns
$t_{\text{HZ}}$	$\overline{\text{HOLD}}$ to Output High Z		100		25	ns
$t_{\text{CS}}$	$\overline{\text{CS}}$ High Time	50		15		ns
$t_{\text{CSS}}$	$\overline{\text{CS}}$ Setup Time	50		15		ns
$t_{\text{CSH}}$	$\overline{\text{CS}}$ Hold Time	50		15		ns
$t_{\text{WPS}}$	$\overline{\text{WP}}$ Setup Time	10		10		ns
$t_{\text{WPH}}$	$\overline{\text{WP}}$ Hold Time	10		10		ns
$t_{\text{WC}}^{(4)}$	Write Cycle Time		5		5	ms

**Power-Up Timing<sup>(2)(3)</sup>**

Symbol	Parameter	Max.	Units
$t_{\text{PUR}}$	Power-up to Read Operation	1	ms
$t_{\text{PUW}}$	Power-up to Write Operation	1	ms

**Notes:**

(1) AC Test Conditions:

 Input Pulse Voltages:  $0.3V_{CC}$  to  $0.7V_{CC}$ 

 Input rise and fall times:  $\leq 10\text{ns}$ 

 Input and output reference voltages:  $0.5V_{CC}$ 

 Output load: current source  $I_{OL\text{ max}}/I_{OH\text{ max}}$ ;  $C_L = 50\text{pF}$ 

(2) This parameter is tested initially and after a design or process change that affects the parameter.

 (3)  $t_{\text{PUR}}$  and  $t_{\text{PUW}}$  are the delays required from the time  $V_{CC}$  is stable until the specified operation can be initiated.

 (4)  $t_{\text{WC}}$  is the time from the rising edge of  $\overline{\text{CS}}$  after a valid write sequence to the end of the internal write cycle.

### PIN DESCRIPTION

**SI:** The serial data input pin accepts op-codes, addresses and data. In SPI modes (0,0) and (1,1) input data is latched on the rising edge of the SCK clock input.

**SO:** The serial data output pin is used to transfer data out of the device. In SPI modes (0,0) and (1,1) data is shifted out on the falling edge of the SCK clock.

**SCK:** The serial clock input pin accepts the clock provided by the host and used for synchronizing communication between host and CAT25010/20/40.

**CS:** The chip select input pin is used to enable/disable the CAT25010/20/40. When CS is high, the SO output is tri-stated (high impedance) and the device is in Standby Mode (unless an internal write operation is in progress). *Every communication session between host and CAT25010/20/40 must be preceded by a high to low transition and concluded with a low to high transition of the CS input.*

**WP:** The write protect input pin will allow all write operations to the device when held high. When WP pin is tied low all write operations are inhibited.

**HOLD:** The HOLD input pin is used to pause transmission between host and CAT25010/20/40, without having to retransmit the entire sequence at a later time. To pause, HOLD must be taken low and to resume it must be taken back high, with the SCK input low during both transitions. When not used for pausing, the HOLD input should be tied to V<sub>CC</sub>, either directly or through a resistor.

### FUNCTIONAL DESCRIPTION

The CAT25010/20/40 devices support the Serial Peripheral Interface (SPI) bus protocol, modes (0,0) and (1,1). The device contains an 8-bit instruction register. The instruction set and associated op-codes are listed in Table 1.

Reading data stored in the CAT25010/20/40 is accomplished by simply providing the READ command and an address. Writing to the CAT25010/20/40, in addition to a WRITE command, address and data, also requires enabling the device for writing by first setting certain bits in a Status Register, as will be explained later.

After a high to low transition on the CS input pin, the CAT25010/20/40 will accept any one of the six instruction op-codes listed in Table 1 and will ignore all other possible 8-bit combinations. The communication protocol follows the timing from Figure 1.

**Table 1: Instruction Set** <sup>(1)</sup>

Instruction	Opcode	Operation
WREN	0000 0110	Enable Write Operations
WRDI	0000 0100	Disable Write Operations
RDSR	0000 0101	Read Status Register
WRSR	0000 0001	Write Status Register
READ	0000 X011	Read Data from Memory
WRITE	0000 X010	Write Data to Memory

**Note:**

(1) X = 0 for CAT25010, CAT25020. X = A8 for CAT25040

**Figure 1. Synchronous Data Timing**

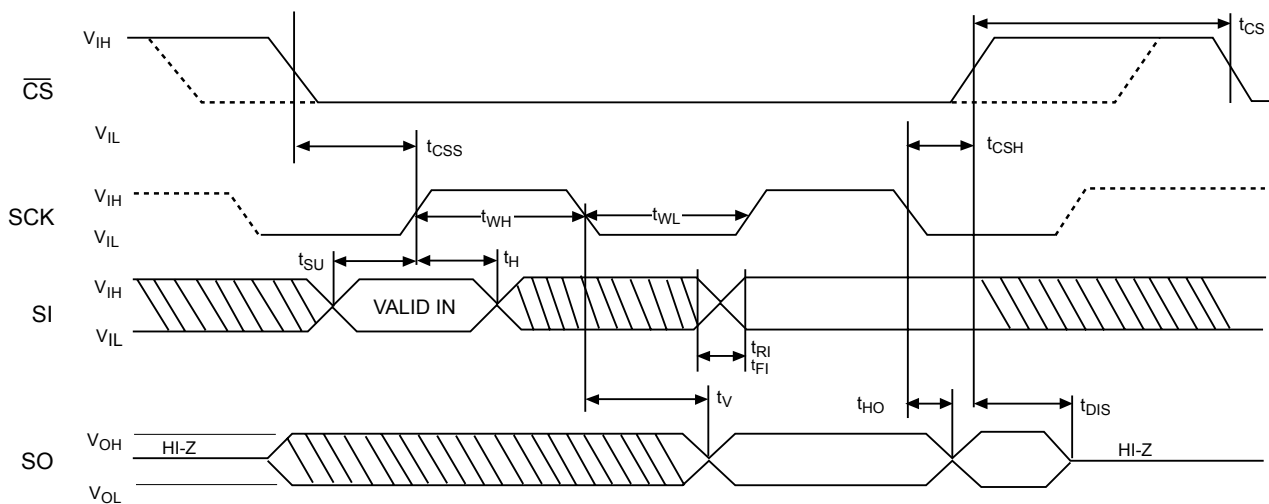

**Note:** Dashed Line = mode (1, 1) -----

## STATUS REGISTER

The Status Register, as shown in Table 2, contains a number of status and control bits.

The  $\overline{\text{RDY}}$  (Ready) bit indicates whether the device is busy with a write operation. This bit is automatically set to 1 during an internal write cycle, and reset to 0 when the device is ready to accept commands. For the host, this bit is read only.

The WEL (Write Enable Latch) bit is set/reset by the WREN/WRDI commands. When set to 1, the device is

in a Write Enable state and when set to 0, the device is in a Write Disable state.

The BP0 and BP1 (Block Protect) bits determine which blocks are currently write protected. They are set by the user with the WRSR command and are non-volatile. The user is allowed to protect a quarter, one half or the entire memory, by setting these bits according to Table 3. The protected blocks then become read-only.

**Table 2. Status Register**

7	6	5	4	3	2	1	0
1	1	1	1	BP1	BP0	WEL	$\overline{\text{RDY}}$

**Table 3. Block Protection Bits**

Status Register Bits		Array Address Protected	Protection
BP1	BP0		
0	0	None	No Protection
0	1	CAT25010: 060-07F CAT25020: 0C0-0FF CAT25040: 180-1FF	Quarter Array Protection
1	0	CAT25010: 040-07F CAT25020: 080-0FF CAT25040: 100-1FF	Half Array Protection
1	1	CAT25010: 000-07F CAT25020: 000-0FF CAT25040: 000-1FF	Full Array Protection

## WRITE OPERATIONS

The CAT25010/20/40 device powers up into a write disable state. The device contains a Write Enable Latch (WEL) which must be set before attempting to write to the memory array or to the status register. In addition, the address of the memory location(s) to be written must be outside the protected area, as defined by BP0 and BP1 bits from the status register.

### Write Enable and Write Disable

The internal Write Enable Latch and the corresponding Status Register WEL bit are set by sending the WREN instruction to the CAT25010/20/40. Care must be taken

to take the  $\overline{CS}$  input high after the WREN instruction, as otherwise the Write Enable Latch will not be properly set. WREN timing is illustrated in Figure 2. The WREN instruction must be sent prior any WRITE or WRSR instruction.

The internal write enable latch is reset by sending the WRDI instruction as shown in Figure 3. Disabling write operations by resetting the WEL bit, will protect the device against inadvertent writes.

**Figure 2. WREN Timing**

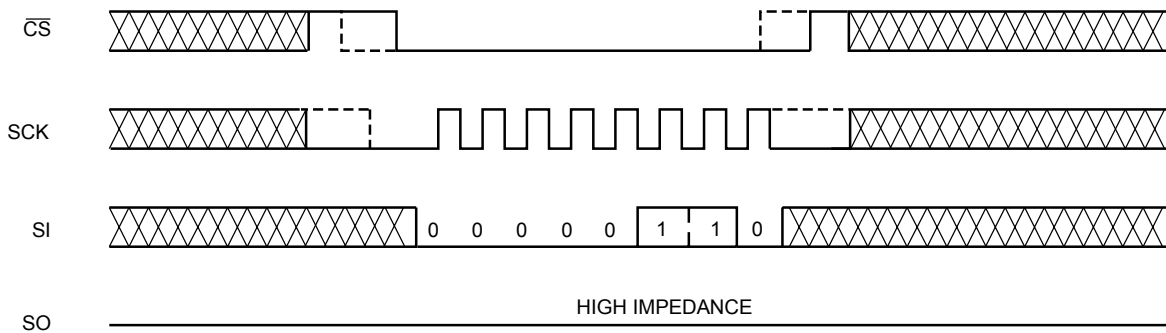

**Note:** Dashed Line = mode (1, 1)-----

**Figure 3. WRDI Timing**

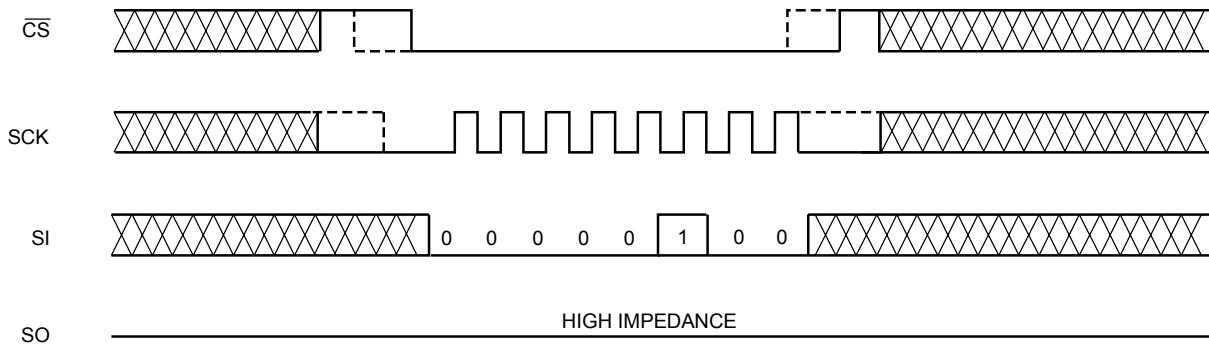

**Note:** Dashed Line = mode (1, 1)-----

**Byte Write**

Once the WEL bit is set, the user may execute a write sequence, by sending a WRITE instruction, a 8-bit address and data as shown in Figure 4. For the CAT25040, bit 3 of the write instruction opcode contains A8 address bit. Internal programming will start after the low to high  $\overline{CS}$  transition. During an internal write cycle, all commands, except for RDSR (Read Status Register) will be ignored. The  $\overline{RDY}$  bit will indicate if the internal write cycle is in progress ( $\overline{RDY}$  high), or the the device is ready to accept commands ( $\overline{RDY}$  low).

**Page Write**

After sending the first data byte to the CAT25010/20/40, the host may continue sending data, up to a total of 16 bytes, according to timing shown in Figure 5. After each data byte, the lower order address bits are automatically incremented, while the higher order address bits (page address) remain unchanged. If during this process the end of page is exceeded, then loading will “roll over” to the first byte in the page, thus possibly overwriting previously loaded data. Following completion of the write cycle, the CAT25010/20/40 is automatically returned to the write disable state.

**Figure 4. Byte WRITE Timing**

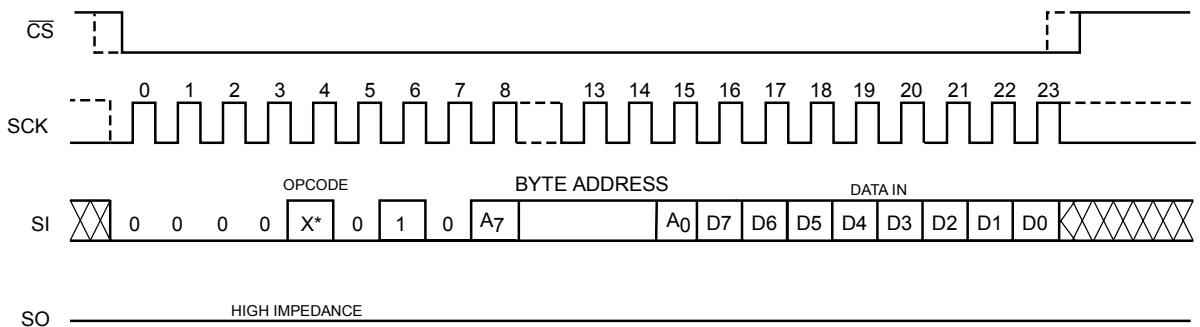

**Notes:**

Dashed Line = mode (1, 1)-----  
\* X = 0 for CAT25010, CAT25020. x = A8 for CAT25040

**Figure 5. Page WRITE Timing**

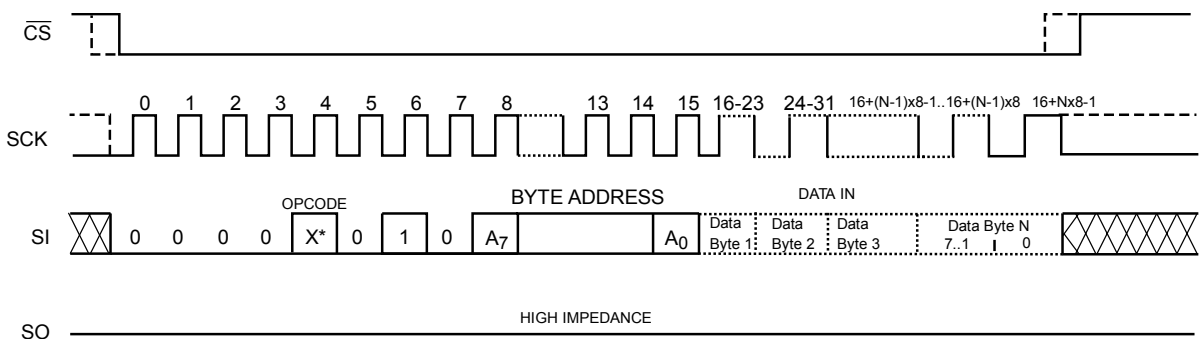

**Notes:**

Dashed Line = mode (1, 1)-----  
\* X = 0 for CAT25010, CAT25020. x = A8 for CAT25040



### Write Status Register

The Status Register is written by sending a WRSR instruction according to timing shown in Figure 6. Only bits 2 and 3 can be written using the WRSR command.

### Write Protection

When  $\overline{WP}$  input is low all write operations to the memory array and Status Register are inhibited.  $\overline{WP}$  going low while  $\overline{CS}$  is still low will interrupt a write to the status register. If the internal write cycle has already been initiated,  $\overline{WP}$  going low will have no effect on any write operation to the Status Register. The  $\overline{WP}$  input timing is shown in Figure 7.

Figure 6. WRSR Timing

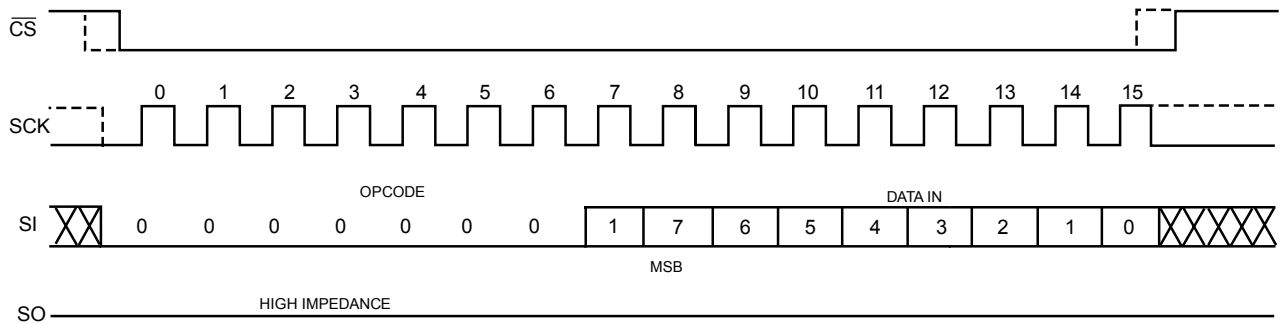

Note: Dashed Line = mode (1, 1) -----

Figure 7. WP Timing

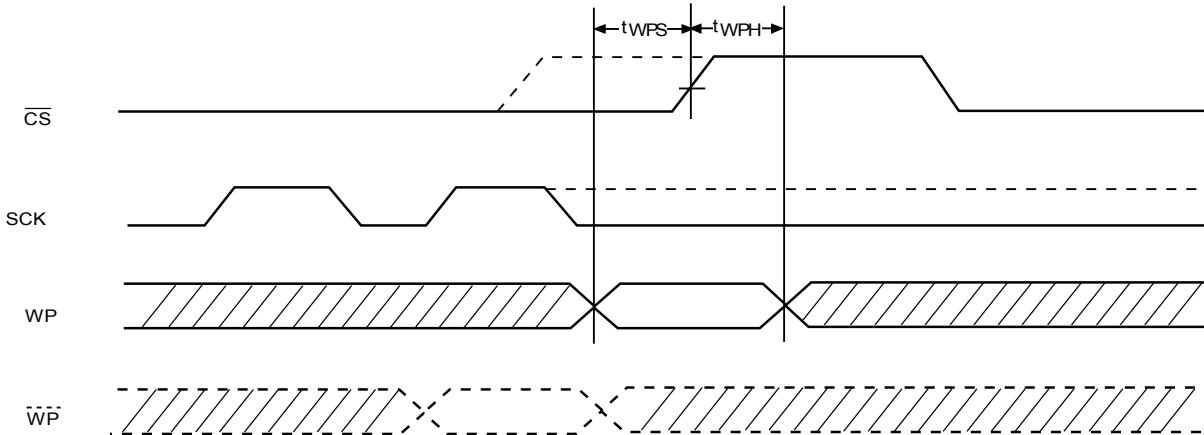

Note: Dashed Line = mode (1, 1) -----

## READ OPERATIONS

### Read from Memory Array

To read from memory, the host sends a READ instruction followed by a 8-bit address (for the CAT25040, bit 3 of the read instruction opcode contains A8 address bit).

After receiving the last address bit, the CAT25010/20/40 will respond by shifting out data on the SO pin (as shown in Figure 8). Sequentially stored data can be read out by simply continuing to run the clock. The internal address pointer is automatically incremented to the next higher address as data is shifted out. After reaching the highest memory address, the address counter “rolls over” to the lowest memory address, and the read cycle can be continued indefinitely. The read operation is terminated by taking  $\overline{CS}$  high.

### Read Status Register

To read the status register, the host simply sends a RDSR command. After receiving the last bit of the command, the CAT25010/20/40 will shift out the contents of the status register on the SO pin (Figure 9). The status register may be read at any time, including during an internal write cycle.

**Figure 8. READ Timing**

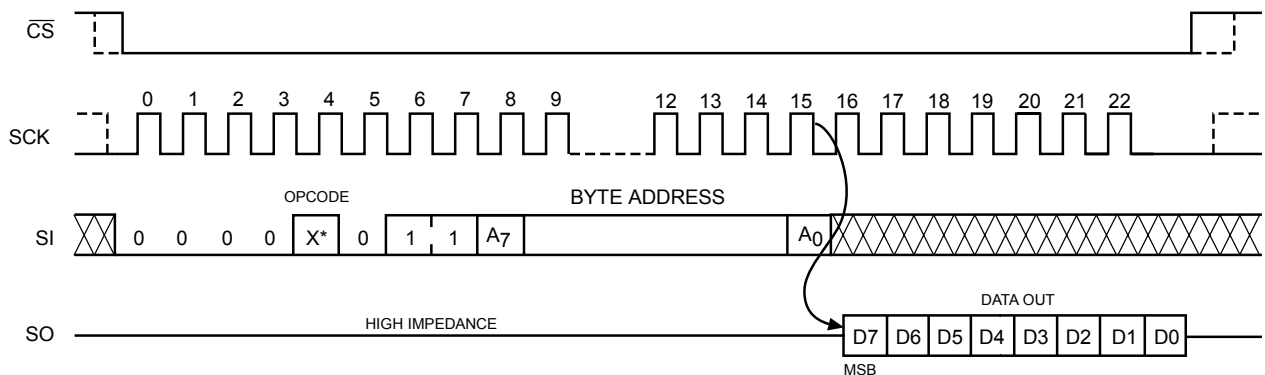

**Notes:**

Dashed Line = mode (1, 1) - - - - -

\* X = 0 for CAT25010, CAT25020. X = A8 for CAT25040

**Figure 9. RDSR Timing**

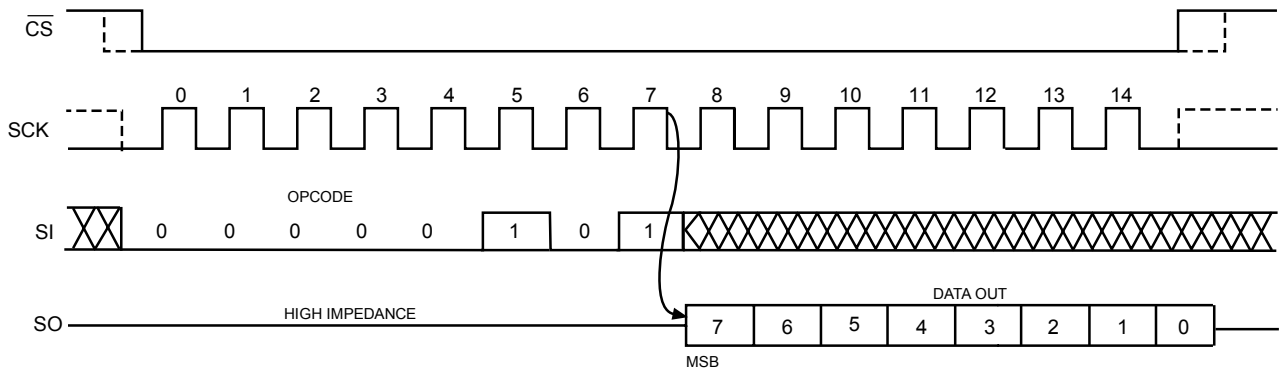

**Note:** Dashed Line = mode (1, 1) - - - - -

### Hold Operation

The  $\overline{\text{HOLD}}$  input can be used to pause communication between host and CAT25010/20/40. To pause,  $\overline{\text{HOLD}}$  must be taken low while SCK is low (Figure 10). During the hold condition the device must remain selected ( $\overline{\text{CS}}$  low). During the pause, the data output pin (SO) is tri-stated (high impedance) and SI transitions are ignored. To resume communication,  $\overline{\text{HOLD}}$  must be taken high while SCK is low.

### DESIGN CONSIDERATIONS

The CAT25010/20/40 devices incorporate Power-On Reset (POR) circuitry which protects the internal logic against powering up in the wrong state. The device will power up into Standby mode after  $V_{CC}$  exceeds the POR trigger level and will power down into Reset mode when  $V_{CC}$  drops below the POR trigger level. This bi-directional POR behavior protects the device against 'brown-out' failure following a temporary loss of power.

The CAT25010/20/40 device powers up in a write disable state and in a low power standby mode. A WREN instruction must be issued prior any writes to the device.

After power up, the  $\overline{\text{CS}}$  pin must be brought low to enter a ready state and receive an instruction. After a successful byte/page write or status register write, the device goes into a write disable mode. The  $\overline{\text{CS}}$  input must be set high after the proper number of clock cycles to start the internal write cycle. Access to the memory array during an internal write cycle is ignored and programming is continued. Any invalid op-code will be ignored and the serial output pin (SO) will remain in the high impedance state.

Figure 10. HOLD Timing

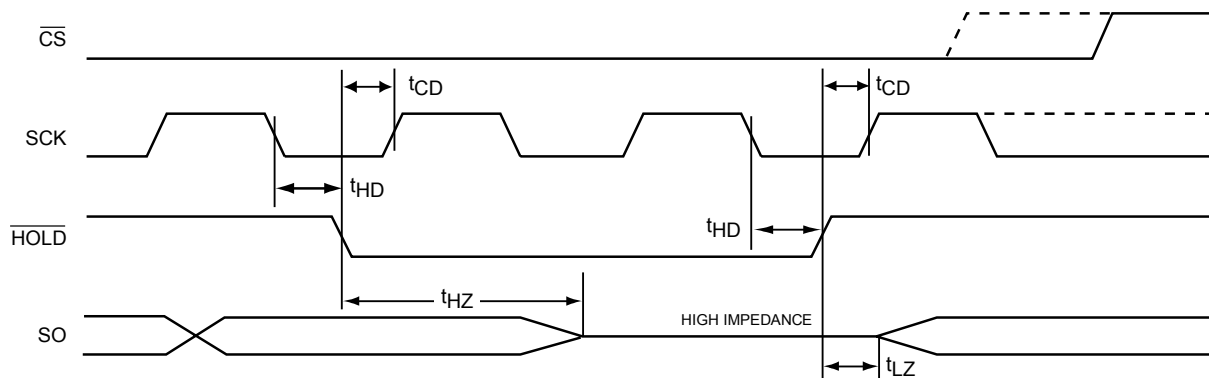

Note: Dashed Line = mode (1, 1) - - - - -

**PACKAGE OUTLINES DRAWING**

**PDIP 8-Lead 300mils (L) <sup>(1)(2)</sup>**

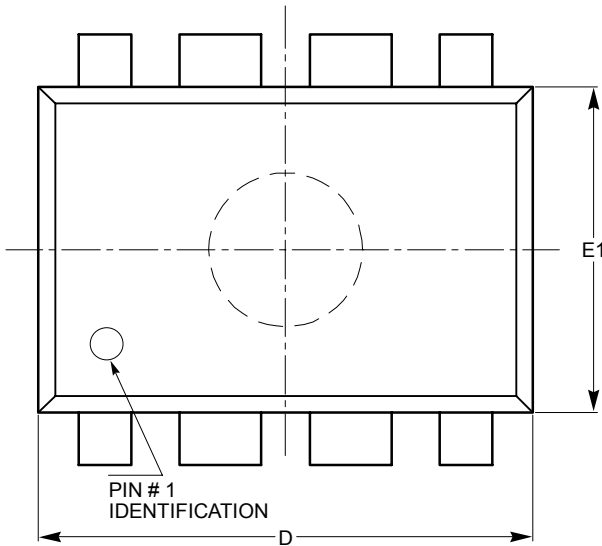

**TOP VIEW**

SYMBOL	MIN	NOM	MAX
A			5.33
A1	0.38		
A2	2.92	3.30	4.95
b	0.36	0.46	0.56
b2	1.14	1.52	1.78
c	0.20	0.25	0.36
D	9.02	9.27	10.16
E	7.62	7.87	8.25
e	2.54 BSC		
E1	6.10	6.35	7.11
eB	7.87		10.92
L	2.92	3.30	3.80

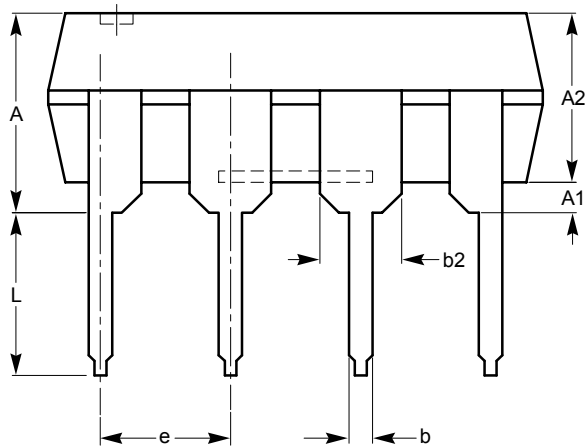

**SIDE VIEW**

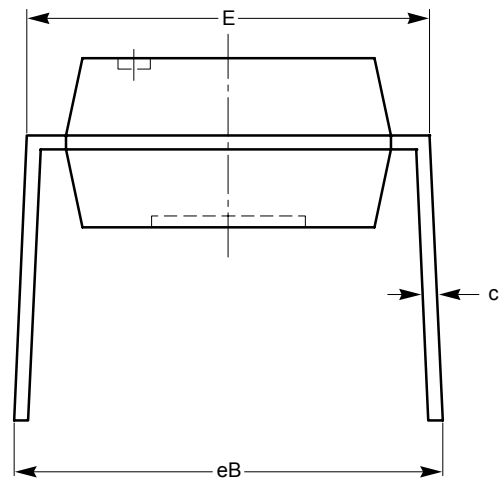

**END VIEW**

**For current Tape and Reel information, download the PDF file from:  
<http://www.catsemi.com/documents/tapeand reel.pdf>.**

**Notes:**

- (1) All dimensions are in millimeters.
- (2) Complies with JEDEC specification MS-001

SOIC 8-Lead 150mils (V) <sup>(1)(2)</sup>

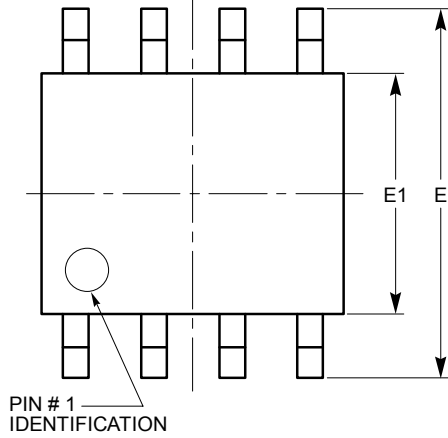

TOP VIEW

SYMBOL	MIN	NOM	MAX
A	1.35		1.75
A1	0.10		0.25
b	0.33		0.51
c	0.19		0.25
D	4.80		5.00
E	5.80		6.20
E1	3.80		4.00
e	1.27 BSC		
h	0.25		0.50
L	0.40		1.27
$\theta$	0°		8°

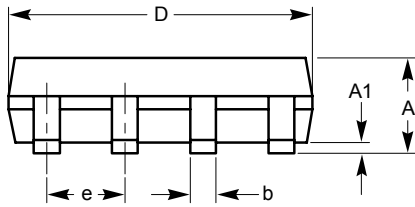

SIDE VIEW

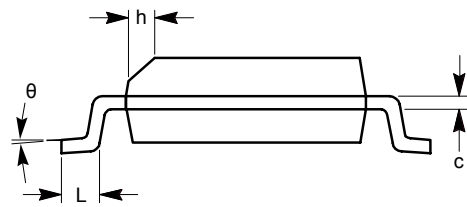

END VIEW

For current Tape and Reel information, download the PDF file from:  
<http://www.catsemi.com/documents/tapeandreel.pdf>.

**Notes:**

- (1) All dimensions are in millimeters.
- (2) Complies with JEDEC specification MS-012.

**TSSOP 8-Lead (Y) <sup>(1)(2)</sup>**

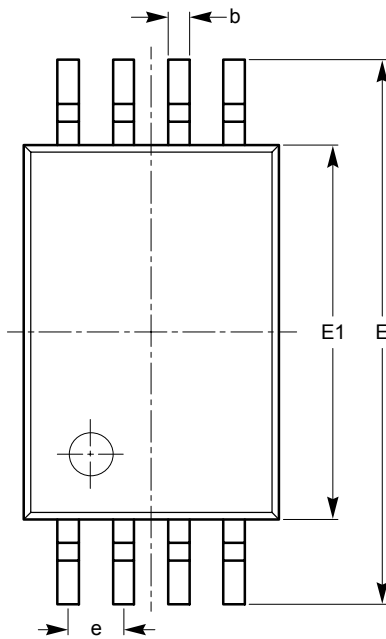

**TOP VIEW**

SYMBOL	MIN	NOM	MAX
A			1.20
A1	0.05		0.15
A2	0.80	0.90	1.05
b	0.19		0.30
c	0.09		0.20
D	2.90	3.00	3.10
E	6.30	6.40	6.50
E1	4.30	4.40	4.50
e	0.65 BSC		
L	1.00 REF		
L1	0.50	0.60	0.75
$\theta 1$	0°		8°

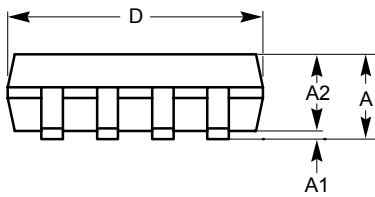

**SIDE VIEW**

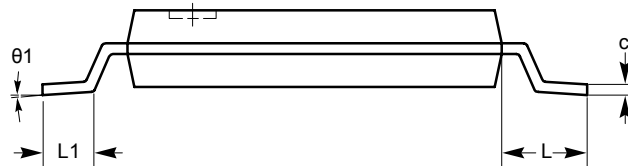

**END VIEW**

**For current Tape and Reel information, download the PDF file from:  
<http://www.catsemi.com/documents/tapeandreel.pdf>.**

**Notes:**

- (1) All dimensions are in millimeters.
- (2) Complies with JEDEC specification MO-153.

TDFN 8-Pad 2 x 3mm (VP2) <sup>(1)(2)</sup>

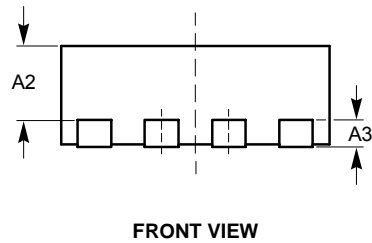
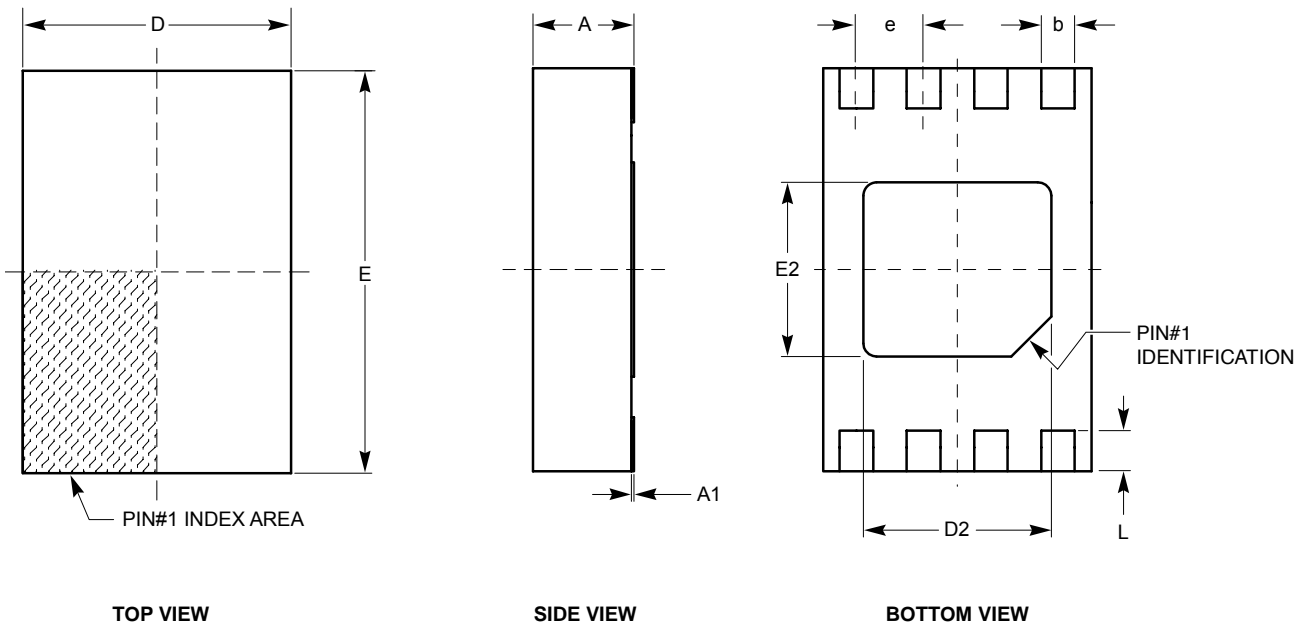

SYMBOL	MIN	NOM	MAX
A	0.70	0.75	0.80
A1	0.00	0.02	0.05
A2	0.45	0.55	0.65
A3	0.20 REF		
b	0.20	0.25	0.30
D	1.90	2.00	2.10
D2	1.30	1.40	1.50
E	2.90	3.00	3.10
E2	1.20	1.30	1.40
e	050 TYP		
L	0.20	0.30	0.40

For current Tape and Reel information, download the PDF file from:  
<http://www.catsemi.com/documents/tapeandreel.pdf>.

Notes:

- (1) All dimensions are in millimeters.
- (2) Complies with JEDEC specification MO-229.

**MSOP 8-Lead 3 x 3mm (Z) <sup>(1)(2)</sup>**

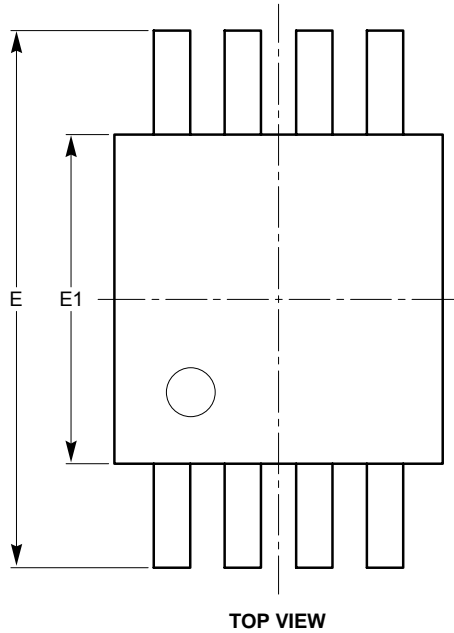

SYMBOL	MIN	NOM	MAX
A			1.10
A1	0.05	0.10	0.15
A2	0.75	0.85	0.95
b	0.22		0.38
c	0.13		0.23
D	2.90	3.00	3.10
E	4.80	4.90	5.00
E1	2.90	3.00	3.10
e	0.65 BSC		
L	0.40	0.60	0.80
L1	0.95 REF		
L2	0.25 BSC		
$\theta$	0°		6°

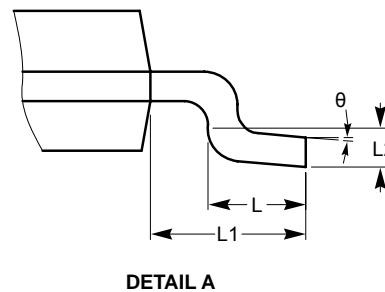
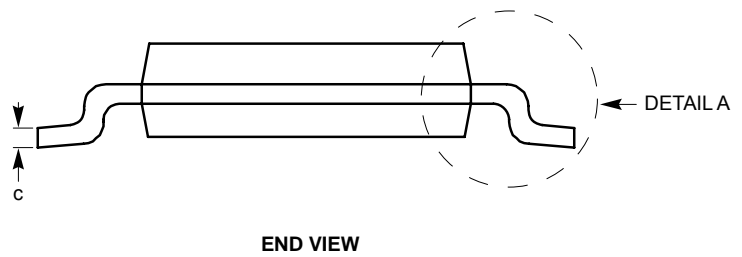
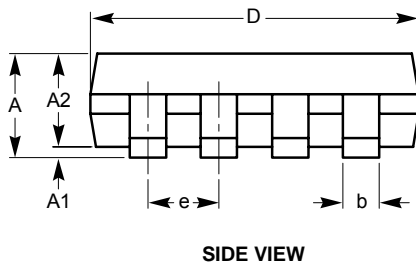

**For current Tape and Reel information, download the PDF file from:  
<http://www.catsemi.com/documents/tapeandreel.pdf>.**

**Notes:**

- (1) All dimensions are in millimeters.
- (2) Complies with JEDEC specification MO-187.



**EXAMPLE OF ORDERING INFORMATION**

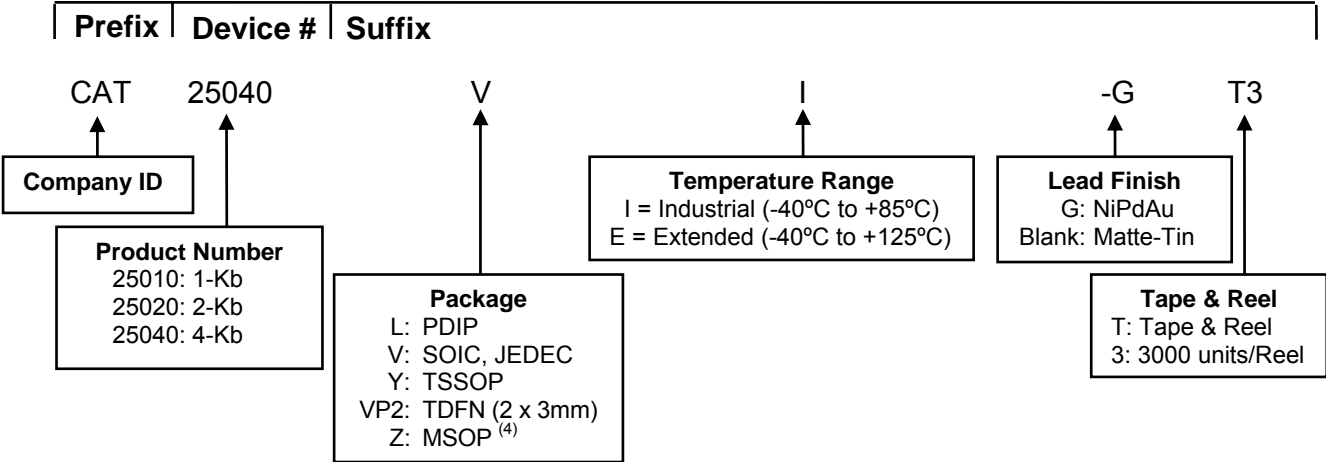

**Notes:**

- (1) All packages are RoHS-compliant (Lead-free, Halogen-free).
- (2) The standard lead finish is NiPdAu.
- (3) The device used in the above example is a CAT25040VI-GT3 (SOIC, Industrial Temperature, NiPdAu, Tape & Reel).
- (4) For availability, please contact your nearest Catalyst Semiconductor Sales office.

## REVISION HISTORY

Date	Rev.	Comments
10/13/05	N	Update D.C. Operating Characteristics Update Ordering Information
12/09/05	O	Update Pin Configuration Update D.C. Operating Characteristics Update Pin Impedance Characteristics Update Figure 2, 3, 4, 6, 8 Add Tape and Reel Update Ordering Information
03/21/06	P	Update D.C. Operating Characteristics Update A.C. Characteristics Update Pin Description
06/30/06	Q	Update Features Update Description Update A.C. Characteristics Update Package Marking Remove Tape and Reel Update Example of Ordering Information
07/31/06	R	Add TDFN and MSOP packages Update Package Marking Update Ordering Information
10/13/06	S	Update Example of Ordering Information
9/14/07	T	Add Extended Temperature range Updated text format Update D.C. Operating Characteristics table for Extended Temperature range Update A.C. Characteristics table for Extended Temperature range Add MD- to document number

### Copyrights, Trademarks and Patents

© Catalyst Semiconductor, Inc.

Trademarks and registered trademarks of Catalyst Semiconductor include each of the following:  
Beyond Memory™, DPP™, EZDim™, LDD™, MiniPot™ and Quad-Mode™

Catalyst Semiconductor has been issued U.S. and foreign patents and has patent applications pending that protect its products.

*CATALYST SEMICONDUCTOR MAKES NO WARRANTY, REPRESENTATION OR GUARANTEE, EXPRESS OR IMPLIED, REGARDING THE SUITABILITY OF ITS PRODUCTS FOR ANY PARTICULAR PURPOSE, NOR THAT THE USE OF ITS PRODUCTS WILL NOT INFRINGE ITS INTELLECTUAL PROPERTY RIGHTS OR THE RIGHTS OF THIRD PARTIES WITH RESPECT TO ANY PARTICULAR USE OR APPLICATION AND SPECIFICALLY DISCLAIMS ANY AND ALL LIABILITY ARISING OUT OF ANY SUCH USE OR APPLICATION, INCLUDING BUT NOT LIMITED TO, CONSEQUENTIAL OR INCIDENTAL DAMAGES.*

Catalyst Semiconductor products are not designed, intended, or authorized for use as components in systems intended for surgical implant into the body, or other applications intended to support or sustain life, or for any other application in which the failure of the Catalyst Semiconductor product could create a situation where personal injury or death may occur.

Catalyst Semiconductor reserves the right to make changes to or discontinue any product or service described herein without notice. Products with data sheets labeled "Advance Information" or "Preliminary" and other products described herein may not be in production or offered for sale.

Catalyst Semiconductor advises customers to obtain the current version of the relevant product information before placing orders. Circuit diagrams illustrate typical semiconductor applications and may not be complete.



Catalyst Semiconductor, Inc.  
Corporate Headquarters  
2975 Stender Way  
Santa Clara, CA 95054  
Phone: 408.542.1000  
Fax: 408.542.1200  
www.catsemi.com

Document No: MD-1006  
Revision: T  
Issue date: 9/14/07