

MCD Electronics Inc.

8100 M4 Wyoming Blvd. NE, #268 Albuquerque, NM 87113
Tel: (505) 246-8000 Fax: (505) 246-9101
E-mail: sales@mcdelectronics.com http://www.mcdelectronics.com

DATA SHEET

PART NO. : MCDL-5T8R6G5B6C-CA

REV : A / 0

CUSTOMER'S APPROVAL : _____ DCC : _____

DRAWING NO. : DS-35-08-0141

DATE : 2008-04-29

Page : 1

5.0 mm DIA LED LAMP

MCDL-5T8R6G5B6C-CA

REV:A / 0

PACKAGE DIMENSIONS

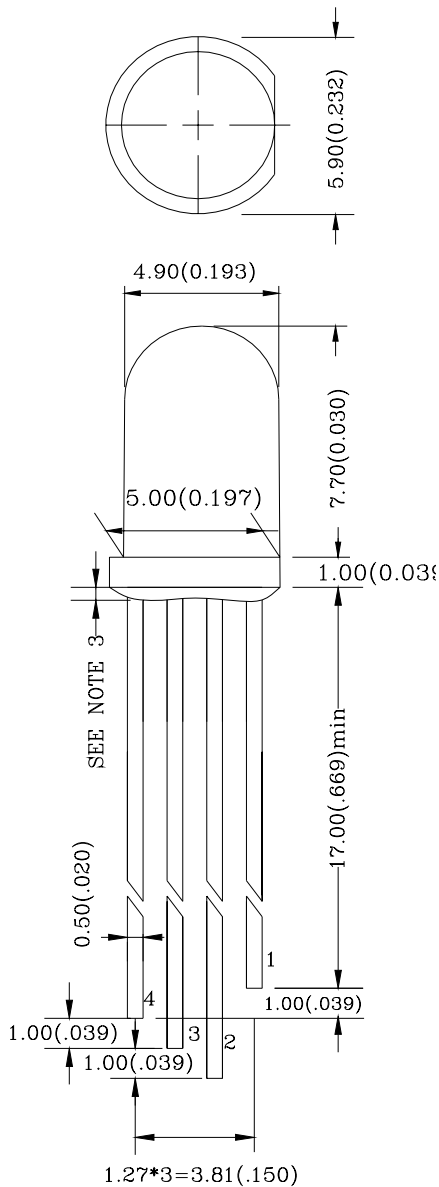

ITEM	MATERIALS
RESIN	Epoxy Resin
LEAD FRAME	Sn Plating iron Alloy

Note:

- All Dimensions are in millimeters.
- Tolerance is $\pm 0.25\text{mm}$ (0.010 ") Unless otherwise specified.
- Protruded resin under flange is 1.5mm (0.059 ") max.
- Lead spacing is measured where the leads emerge from the package.
- Specification are subject to change without notice
- highlight $< -400\text{V}$ the led can withstand the max static level when assembling or operation (HBM).
- The lamps have sharp and hard points that may injure human eyes or fingers etc., so please pay enough care in the handling.

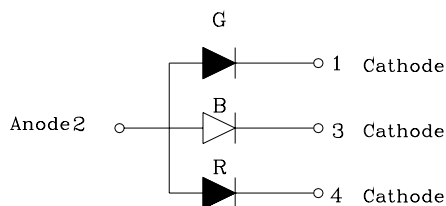

5.0 mm DIA LED LAMP

MCDL-5T8R6G5B6C-CA

REV:A / 0

FEATURES

- * SUITABLE HIGH PULSE CURRENT OPERATION
- * EXTRA HIGH RADIANT POWER AND RADIANT INTENSITY
- * HIGH RELIABILITY
- * LOW FORWARD VOLTAGE
- * Pb FREE PRODUCTS

CHIP MATERIALS

- * Dice Material : GaAlInP/Si & GaInN/GaN & GaInN/GaN
- * Light Color : FULL COLOR(ULTRA ORANGE & ULTRA PURE GREEN & ULTRA BLUE)
- * Lens Color : WATER CLEAR

ABSOLUTE MAXIMUM RATING : (Ta = 25°C)

SYMBOL	DESCRIPTION	ULTRA ORANGE	ULTRA PURE GREEN	ULTRA BLUE	UNIT
PD	Power Dissipation Per Chip	85	120	120	mW
VR	Reverse Voltage Per Chip	5	5	5	V
IF	Average Forward Current Per Chip	30	30	30	mA
IPF	Peak Forward Current (Duty=0.1,1KHZ) Per Chip	150	120	70	mA
-	Derating Linear From 25°C Per Chip	0.4	0.4	0.4	mA/°C
Topr	Operating Temperature Range	-25°C to 85°C			
Tstg	Storage Temperature Range	-25°C to 85°C			

ELECTRO-OPTICAL CHARACTERISTICS : (Ta = 25°C)

SYMBOL	PARAMETER	TEST CONDITION	MIN.	TYP.	MAX.	UNIT
VF	Forward Voltage	IF=20mA	Ultra Orange	2.25	2.8	V
			Ultra Pure Green	3.5	4.0	V
			Ultra Blue	3.5	4.0	V
IR	Reverse Current	VR=5V	Ultra Orange		100	μA
			Ultra Pure Green		100	μA
			Ultra Blue		100	μA
λD	Dominant Wavelength	IF=20mA	Ultra Orange	624		nm
			Ultra Pure Green	525		nm
			Ultra Blue	470		nm
Δλ	Spectral Line Half-Width	IF=20mA	Ultra Orange	20		nm
			Ultra Pure Green	22		nm
			Ultra Blue	30		nm
2θ1/2	Half Intensity Angle	IF=20mA	Ultra Orange	20		deg
			Ultra Pure Green	20		deg
			Ultra Blue	20		deg
IV	Luminous Intensity	IF=20mA	Ultra Orange	3500		mcd
			Ultra Pure Green	4000		mcd
			Ultra Blue	2000		mcd

5.0 mm DIA LED LAMP

MCDL-5T8R6G5B6C-CA

REV:A/0

G5 B6

Forward Voltage vs. Forward Current

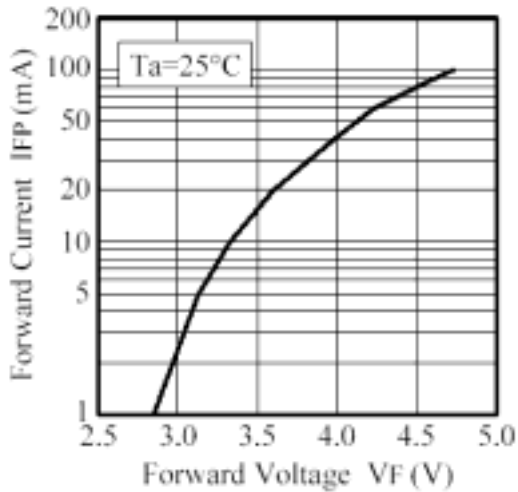

Forward Current vs. Relative luminosity

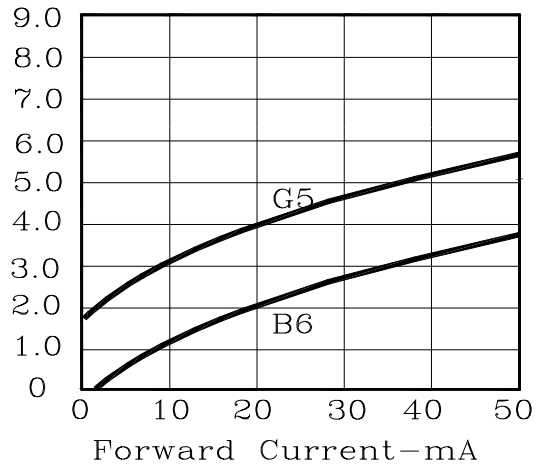

Duty Ratio vs. Allowable Forward Current

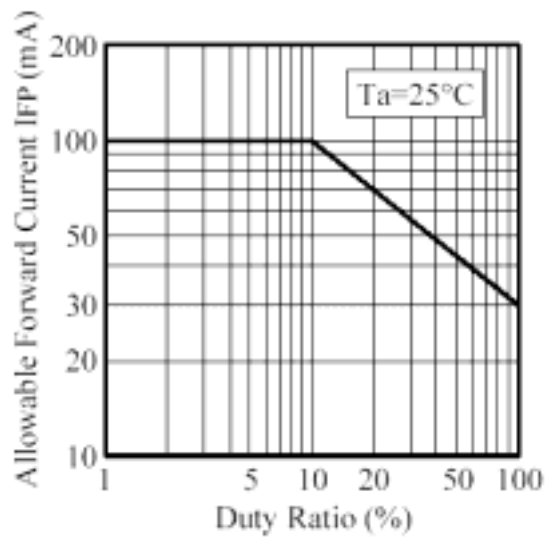

Ambient Temperature vs. Forward Voltage

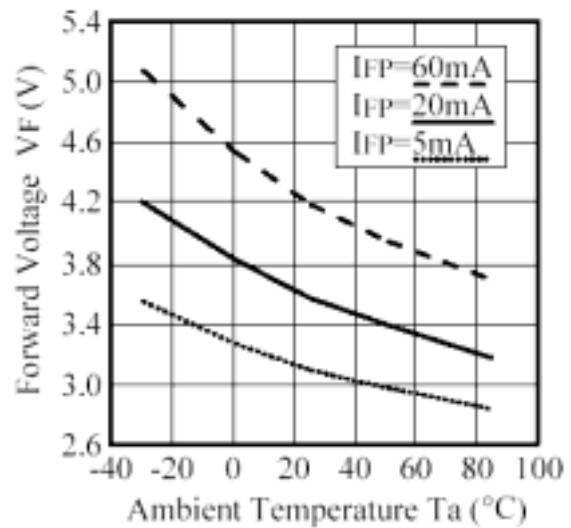

5.0 mm DIA LED LAMP

MCDL-5T8R6G5B6C-CA

REV:A / 0

G5 B6

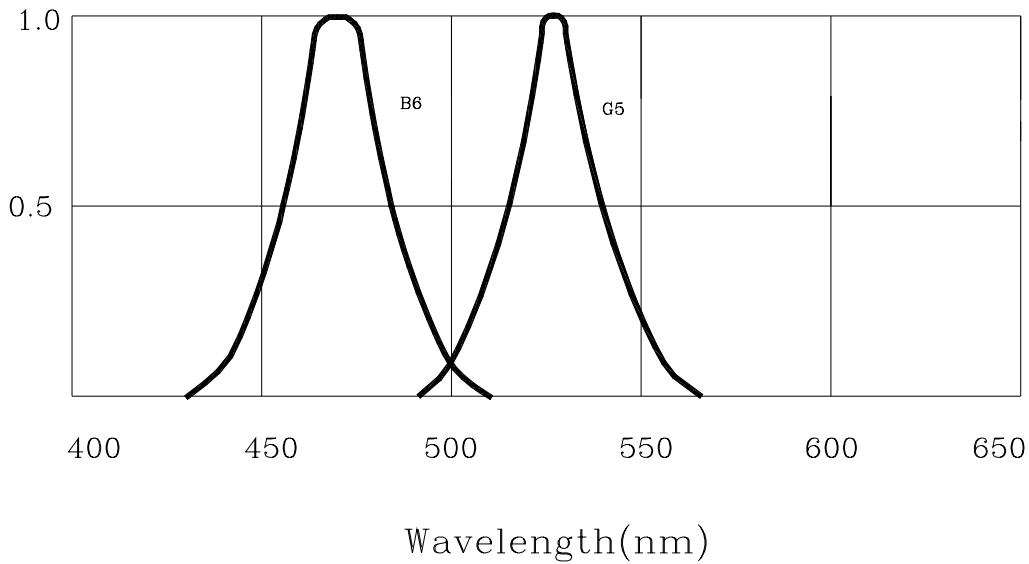
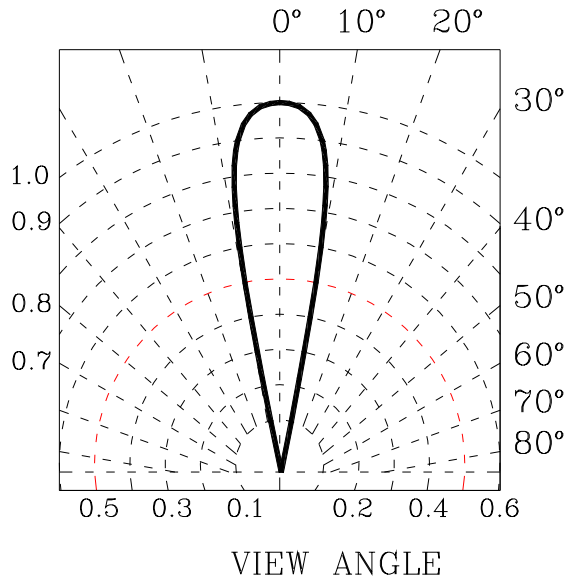

5.0 mm DIA LED LAMP

MCDL-5T8R6G5B6C-CA

REV:A/0

R6

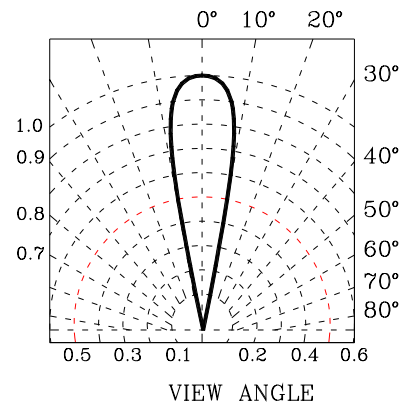
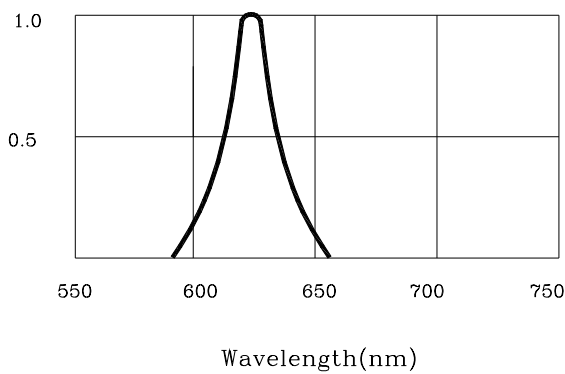
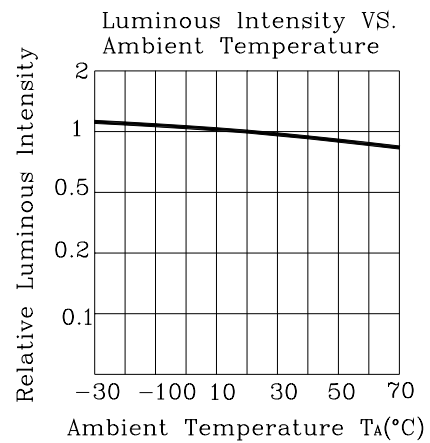
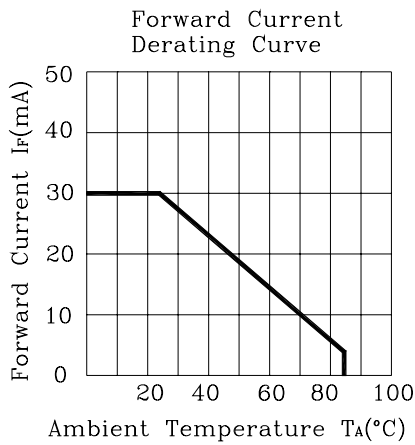
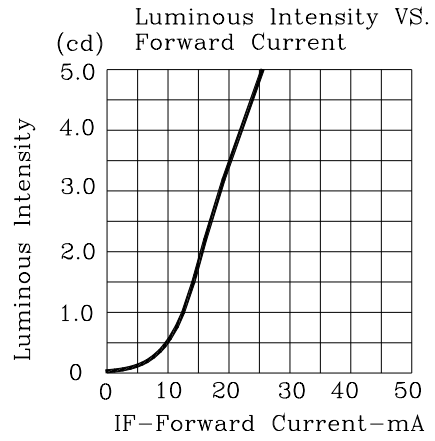
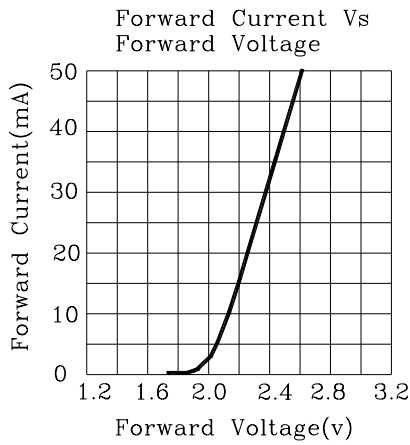

5.0 mm DIA LED LAMP

MCDL-5T8R6G5B6C-CA

REV:A / 0

●SOLDERING

METHOD	SOLDERING CONDITIONS	REMARK
DIP SOLDERING	Bath temperature: 260 Immersion time: with 5 sec, 1 time	<ul style="list-style-type: none"> • Solder no closer than 3mm from the base of the package • Using soldering flux, "RESIN FLUX" is recommended. • Attached data of temperature cure for your reference
SOLDERING IRON	Soldering iron: 30W or smaller Temperature at tip of iron: 300 or lower Soldering time: within 5 sec.	<ul style="list-style-type: none"> • During soldering, take care not to press the tip of iron against the lead. (To prevent heat from being transferred directly to the lead, hold the lead with a pair of tweezers while soldering

1) When soldering the lead of LED in a condition that the package is fixed with a panel (See Fig.1), be careful not to stress the leads with iron tip.

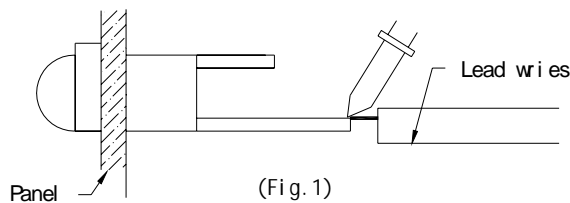

2) When soldering wire to the lead, work with a Fig (See Fig.2) to avoid stressing the package.

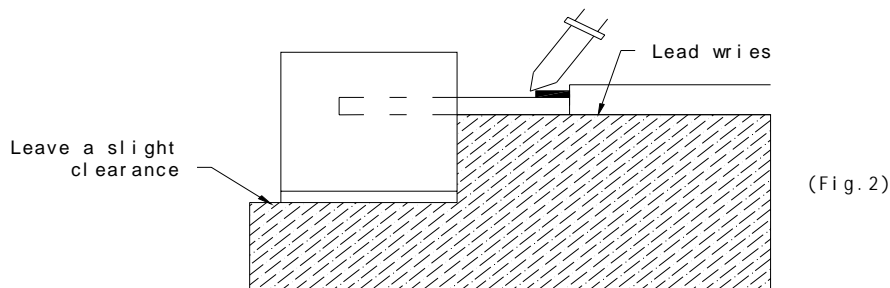

Regarding solution in the tinning oven for product-tinning, compound sub-solution made of tin & copper and silver is proposed with the temperature of Celsius 260. The proportion of the alloyed solution is tin 95.5: copper 3.5: silver 0.5 by percentage. The time of tinning is constantly 3 seconds.

5.0 mm DIA LED LAMP

MCDL-5T8R6G5B6C-CA

REV:A / 0

- 3) Similarly, when a jig is used to solder the LED to PC board, take care as much as possible to avoid steering the leads (See Fig.3).

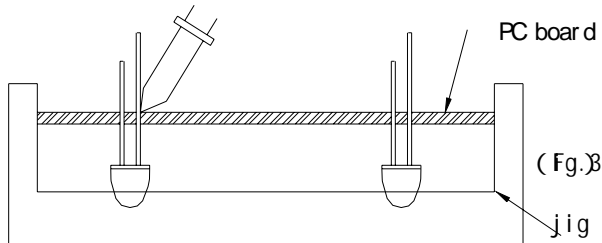

- 4) Repositioning after soldering should be avoided as much as possible. If inevitable, be sure to preserve the soldering conditions with irons stated above: select a best-suited method that assures the least stress to the LED.
- 5) Lead cutting after soldering should be performed only after the LED temperature has returned to normal temperature.

● STORAGE

- 1) The LEDs should be stored at 30 °C or less and 70% RH or less after being shipped from PARA and the storage life limits are 3 months .
- 2) PARA LED lead frames are comprised of a stannum plated iron alloy. The silver surface may be affected by environments which contain corrosive gases and so on. Please avoid conditions which may cause the LEDs to corrode, tarnish or discolor. This corrosion or discoloration may cause difficulty during soldering operations. It is recommended that the LEDs be used as soon as possible.

Please avoid rapid transitions in ambient temperature, especially, in high humidity environments where condensation can occur.

● STATIC ELECTRICITY

- 1) Static electricity or surge voltage damages the LEDs.
It is recommended that a wrist band or an anti-electrostatic glove be used when handling the LEDs.
- 2) All devices, equipment and machinery must be properly grounded. It is recommended that measures be taken against surge voltage to the equipment that mounts the LEDs.
- 3) When inspecting the final products in which LEDs were assembled, it is recommended to check whether the assembled LEDs are damaged by static electricity or not. It is easy to find static-damaged LEDs by a light-on test or a VF test at a lower current (below 1mA is recommended).
- 4) Damaged LEDs will show some unusual characteristics such as the leak current remarkably increases, the forward voltage becomes lower, or the LEDs do not light at the low current .

Criteria : (VF>2.0V at IF=0.5mA)

5.0 mm DIA LED LAMP

MCDL-5T8R6G5B6C-CA

REV:A / 0

•LED MOUNTING METHOD

- 4) When mounting the LED by using a case, as shown Fig.4, ensure that the mounting holds on the PC board match the pitch of the leads correctly-tolerance of dimensions of the respective components including the LED should be taken into account especially when designing the case, PC board, etc. to prevent pitch misalignment between the leads and board holes, the diameter of the board holes should be slightly larger than the size of the lead. Alternatively, the shape of the holes should be made oval. (See Fig.4)

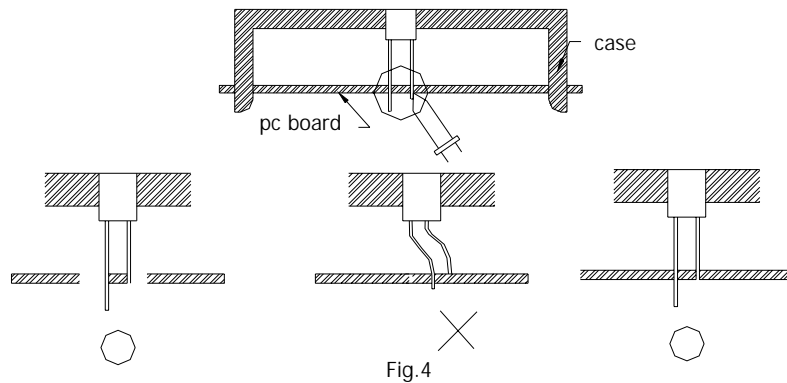

- 5) Use LEDs with stand-off (Fig.5) or the tube or spacer made of resin (Fig.6) to position the LEDs.

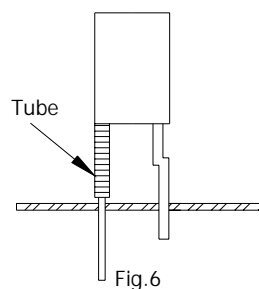
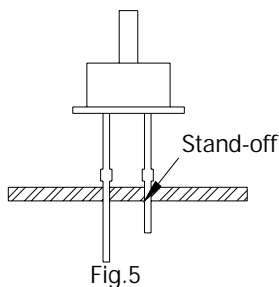

5.0 mm DIA LED LAMP

MCDL-5T8R6G5B6C-CA

REV:A / 0

•FORMED LEAD

- 1) The lead should be bent at a point located at least 2mm away from the package. Bending should be performed with base fixed means of a jig or pliers (Fig.7)

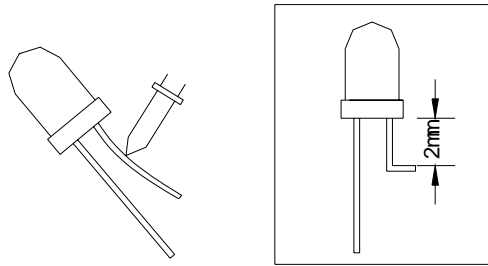

Fig. 7

- 2) Forming lead should be carried out prior to soldering and never during or after soldering.
- 3) Form the lead to ensure alignment between the leads and the hole on board, so that stress against the LED is prevented. (Fig.8)

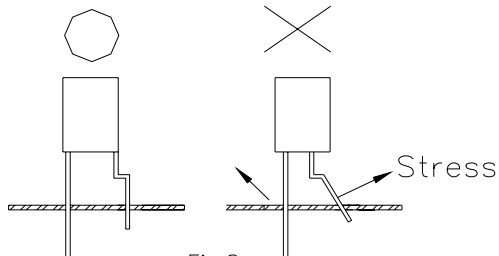

Fig.8

•LEAD STRENGTH

- 1) Bend strength
Do not bend the lead more than twice. (Fig.9)

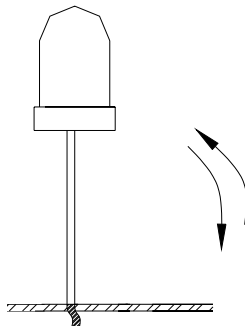

Fig.9

5.0 mm DIA LED LAMP

MCDL-5T8R6G5B6C-CA

REV:A / 0

2) Tensile strength (@Room Temperature)

If the force is 1kg or less, there will be no problem. (Fig.10)

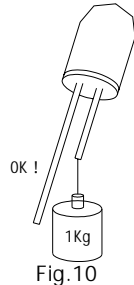

• HEAT GENERATION

- 1) Thermal design of the end product is of paramount importance. Please consider the heat generation of the LED when making the system design. The coefficient of temperature increase per input electric power is affected by the thermal resistance of the circuit board and density of LED placement on the board, as well as other components. It is necessary to avoid intense heat generation and operate within the maximum ratings given in this specification.

The operating current should be decided after considering the ambient maximum temperature of LEDs.

•CHEMICAL RESISTANCE

- 1) Avoid exposure to chemicals as it may attack the LED surface and cause discoloration.
- 2) When washing is required, refer to the following table for the proper chemical to be used.
(Immersion time: within 3 minutes at room temperature.)

SOLVENT	ADAPTABILITY
Freon TE	
Chloroethene	
Isopropyl Alcohol	
Thinner	
Acetone	
Trichloroethylene	

--Usable --Do not use.

NOTE: Influences of ultrasonic cleaning of the LED resin body differ depending on such factors as the oscillator output, size of the PC board and the way in which the LED is mounted. Therefore, ultrasonic cleaning should only be performed after confirming there is no problem by conducting a test under practical.

5.0 mm DIA LED LAMP

MCDL-5T8R6G5B6C-CA

REV:A / 0

Bin Code List

Forward Voltage (VF), Unit:v@20mA					
Bin Code(B6)	Min	Max	Bin Code(G5)	Min	Max
V1	2.88	3.33	V1	2.88	3.33
V2	3.07	3.54	V2	3.07	3.54
V3	3.16	3.74	V3	3.16	3.74
V4	3.46	3.95	V4	3.46	3.95
V5	3.65	4.0	V5	3.65	4.0

Dominant Wavelength(λ_D), Unit:nm@20mA					
Bin Code(B6)	Min	Max	Bin Code(G5)	Min	Max
D3	459	464	D3	509	516
D4	462	467	D4	514	521
D5	465	470	D5	519	526
D6	468	473	D6	524	531
D7	471	475	D7	529	536

Luminous Intensity(IV), Unit:mcd@20mA								
Bin Code(R6)	Min	Max	Bin Code(G5)	Min	Max	Bin Code(B6)	Min	Max
W	1671.3	2339.8	I	1510	2110	G	770	1080
X	2339.8	3275.7	J	2110	2950	H	1080	1510
Y	3275.7	4586	K	2950	4130	I	1510	2110
Z	4586	6421.8	L	4130	5780	J	2110	2950
Z1	6421.8	8027.3	M	5780	8090	K	2950	4130

Tolerance of each bin are $\pm 15\%$

5.0 mm DIA LED LAMP

MCDL-5T8R6G5B6C-CA

REV:A / 0

LED Lamps:

