

THIS DOCUMENT IS THE PROPERTY OF  
KEYSTONE ELECTRONICS CORP. AND  
SHALL NOT BE REPRODUCED, DISTRIBUTED  
OR USED AS A BASIS FOR MANUFACTURE  
WITHOUT PRIOR WRITTEN PERMISSION  
FROM KEYSTONE ELECTRONICS CORP.

ACTUAL SIZE

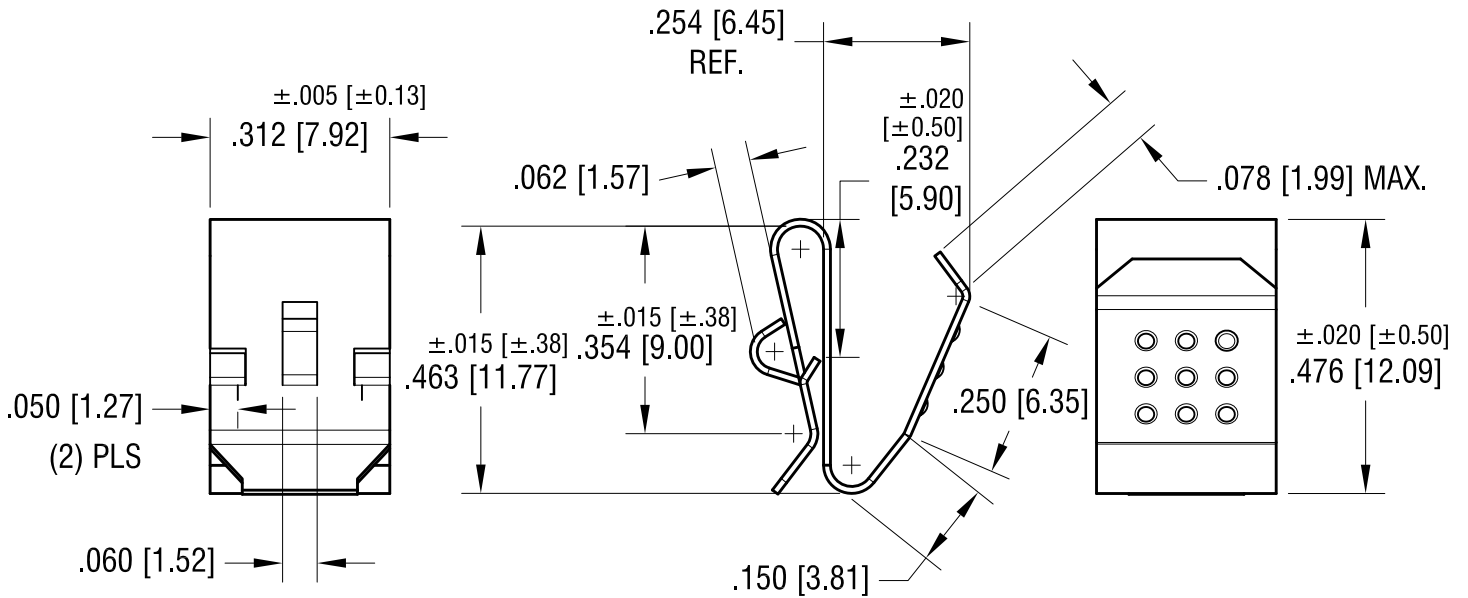
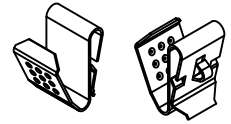

**NOTE:**

1. HEAT TREAT TO SPRING TEMPER.
2. DESIGNED TO CLIP OVER PANELS FROM .060 [1.52] THRU .070 [1.78] TH'K.

11.30.16	CHANGE AS PER ECN 16-099	R
6.16.16	CHANGE AS PER ECN 16-065	P
2.09.16	CHANGE AS PER ECN 16-024	N
8.17.09	CHANGE AS PER ECN 09-117	M
12.23.04	CHANGE AS PER ECN 04-174	L
DATE	DESCRIPTION	REV.

<b>KEYSTONE ELECTRONICS CORP.</b>			
www.keyelco.com • NEW HYDE PARK, NY 11040 • Tel (516) 328-7500			
PART NAME		SINGLE 'A' - 'AA' CONTACT	
MATERIAL		.012 [0.30] TH'K SPRING STEEL	
FINISH		DRN BY	DATE
NICKEL PLATE		BOONE	4.27.83
		APP'D	SCALE
		LN	3X
TOLERANCES	INCH [MM]	CODE	DWG NO.
DECIMAL	± .010 [± 0.25]	C	<b>209</b>
ANGULAR	± 1°		
UNLESS OTHERWISE SPECIFIED			