

# SPECIFICATION FOR APPROVAL

CUSTOMER: JAMES

PART NO:

MODEL NO: ADU150100

DESIGNED NO: V0360 RoHS

REVISION: 1-0

CATEGORY: AC ADAPTOR

DATE SUBMITTED: 2018.08.14

SAMPLE/SPECIFICATION SUBMITTED		CONCLUSION	APPROVED
SAMPLE 0			REJECTED
SPECIFICATION 1			CONDITION APP'D

CUSTOMER'S SIGNATURE:

浩源實業有限公司  
HAWK'S AIM INDUSTRIAL CO., LTD.  
高雄市前鎮區新衙路 286-8 號 5F-2  
5F-2, No.286-8, Shin-Ya Road, Chien-Chen  
District, Kaohsiung, Taiwan 806  
Tel:07-8418448 Fax:07-8419997

MODEL NO: ADU150100  
 CUSTOMER P/N:  
 DESCRIPTION: AC ADAPTOR  
 ISSUED DATE: 2018.08.14  
 REVISION: 1-0

TABLE OF CONTENTS

- 1.0 ELECTRICAL CHARACTERISTIC
- 2.0 MECHANICAL PERFORMANCE
- 3.0 SAFETY STANDARD
- 4.0 APPEARANCE REQUIREMENTS
- 5.0 ENVIRONMENTAL CONDITION
- 6.0 INSPECTION ON LINE
- 7.0 NET WEIGHT
- 8.0 APPEARANCE DIMENSION
- 9.0 MATERIAL LIST
- 10.0 NAMEPLATE DRAWING

REV	DESCRIPTION	DATE
1-0	INITIAL RELEASED	2018.08.14

APP.BY \_\_\_\_\_

CHK.BY \_\_\_\_\_

PRE.BY \_\_\_\_\_

1.0 ELECTRICAL CHARACTERISTIC:

- 1.1 INPUT RATED VOLTAGE AND LINE FREQUENCY: 120 VAC 60 Hz.
- 1.2 INPUT EXCITING CURRENT (Io): 80 mA RMS MAX. AT INPUT 120 VAC 60 Hz.
- 1.3 INPUT LOAD CURRENT (IP): 220 mA RMS MAX. INPUT 120 VAC 60 Hz OUTPUT FULL LOAD.
- 1.4 EMPTY LOSS: X W MAX, AT INPUT X VAC X Hz.
- 1.5 ELECTRICAL CIRCUIT:



1.6 OUTPUT RATED VOLTAGE AND CURRENT:

TEST POINT	FULL LOAD RATED VOLTAGE	RATED CURRENT	RIPPLE VOLTAGE Vp-p	NO LOAD VOLTAGE
	15VAC±5%	1000mA	mV MAX.	18.5VAC±5%

- 1.7 D.C.RESISTANCE:PRIMARY X Ω±5%, MEASURED AT 25°C AMBIENT TEMPERATURE.
- 1.8 HI-POT TEST: 1240 VAC 50/60HZ FOR 60 SECONDS BETWEEN INPUT TO OUTPUT PLUG AND CASE NORMAL PERFORMANCE. (LEAKAGE CURRENT 1mA)
- 1.9 INSULATION RESISTANCE TEST: 500 VDC SUPPLIED, 100 MΩ MIN, BETWEEN INPUT TO OUTPUT PLUG AND CASE.
- 1.10 TEMPERATURE RISE TEST: INPUT 120 VAC 60 Hz, OUTPUT LOAD 1.0 A FOR INPUT COIL 75 °C MAX (BY USE RESISTANCE METHOD) ON CASE SURFACE X °C MAX (BY USE THERMOMETER METHOD) AT 25°C AMBIENT TEMPERATURE.
- 1.11 HUMIDITY TEST: IN AN AMBIENT TEMPERATURE 40±2 °C AND 90-95 % R.H FOR 4 HOURS, AFTER 10 MINUTES OUT OF THE OVEN, THE UNIT SHOULD MEET ITEM 1.8 REQUIREMENTS, AND INSULATION RESISTANCE SHALL BE 10M OHMS MIN.

2.0 MECHANICAL PERFORMANCE:

- 2.1 STRAIN RELIEF TEST: AT NORMAL POSITION, 20 LBS TO OUTPUT CORD FOR 60 SECONDS EACH, THERE SHALL BE NO BREAKAGE DISPLACEMENT.
- 2.2 DROP TEST: DROPPED FREELY FROM 3 FEET HEIGHT ONTO A CONCRETE FLOOR COVERED WITH 1/8 INCH VINYL TILE 3 TIMES FROM 3 DIFFERENT SURFACE THE UNIT SHOULD MEET THE ITEM 1.8 · 1.9.

APP.BY \_\_\_\_\_

CHK.BY \_\_\_\_\_

PRE.BY \_\_\_\_\_

2.3 BENDING TEST: THE PLUG AND S/R SHOULD WITHSTAND WEIGHT OF 200 GRAM, IT SWINGING FROM LEFT TO RIGHT AT AN ANGLE OF 120 DEGREE FOR 300 CYCLES, AND 15-20 CYCLES PER MINUTE, THE CORD SHALL BE CONDUCTIBLE.

3.0 SAFETY STANDARD:

UL/CUL      GS      CE      PSE      BSMI

4.0 APPEARANCE REQUIREMENTS:

4.1 APPEARANCE: DAMAGE AND RUSTING ARE NOT PERMITTED.

5.0 ENVIRONMENTAL CONDITION:

5.1 OPERATING TEMPERATURE RANGE: -10°C ----- +40°C

5.2 STORAGE TEMPERATURE RANGE: -20°C ----- +55°C

5.3 OPERATING HUMIDITY RANGE: 30-85% R.H.

6.0 INSPECTION ON LINE:

6.1 THE TEST ITEMS FOR EACH PRODUCE.

◇ PRIMARY EXCITING CURRENT

◇ CORE LOSS

◇ OUTPUT VOLTAGE

◇ INPUT CURRENT AND POWER AT RATED LOAD

◇ FOREIGN MASS BY SHOCK

◇ POLARITY OF OUTPUT PLUG

◇ HI-POT TEST

◇ APPERANCE

6.2 THE TEST ITEM FOR PART OF PRODUCTS.

◇ HUM OPERATING AT RATED LOAD

◇ D.C.RESISTANCE

◇ INSULATION TEST

7.0 NET WEIGHT: X g

APP.BY \_\_\_\_\_

CHK.BY \_\_\_\_\_

PRE.BY \_\_\_\_\_

8.0 APPEARANCE DIMENSIONS: (UNIT:mm)

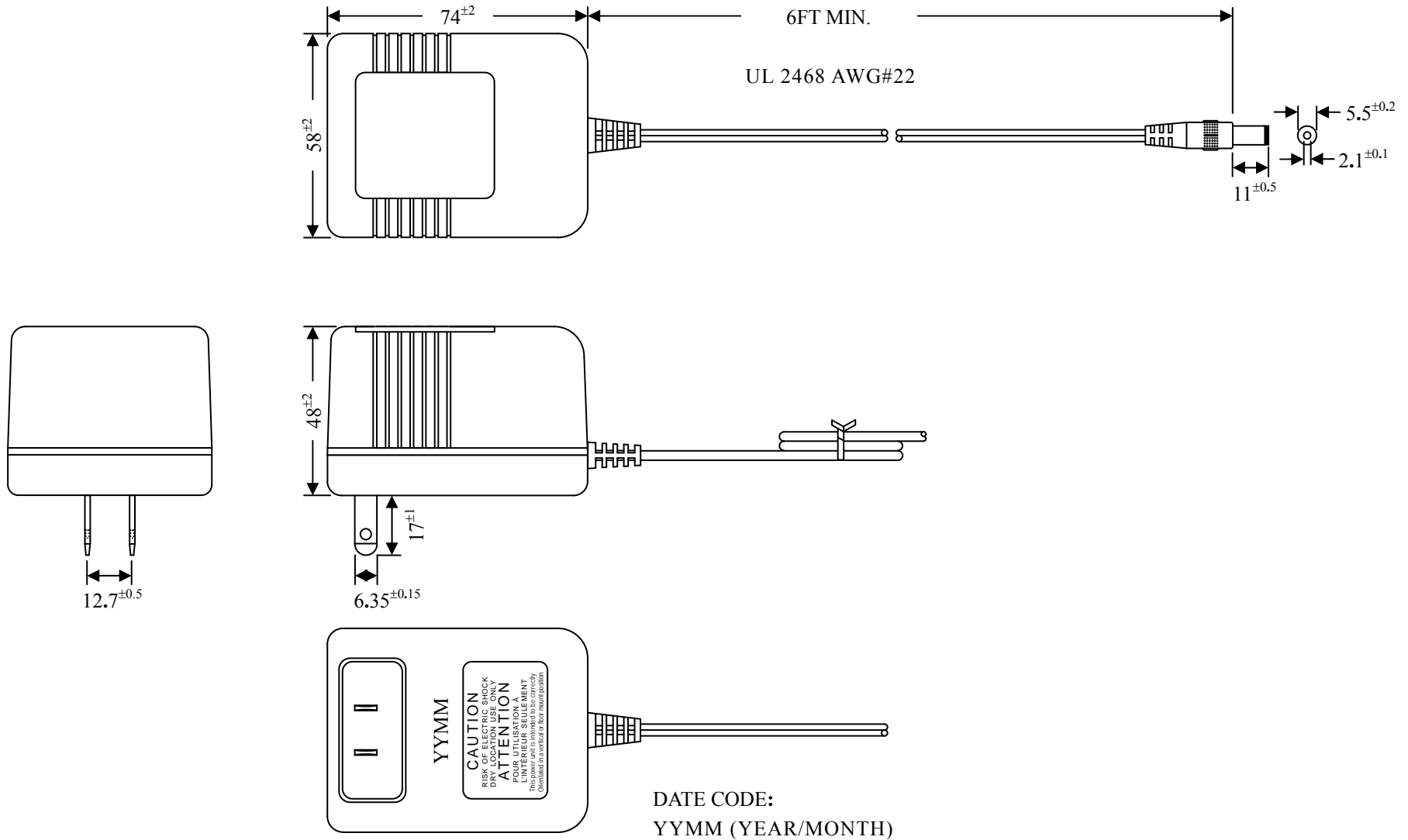

APP.BY \_\_\_\_\_

CHK.BY \_\_\_\_\_

PRE.BY \_\_\_\_\_

9.0 MATERIAL LIST:

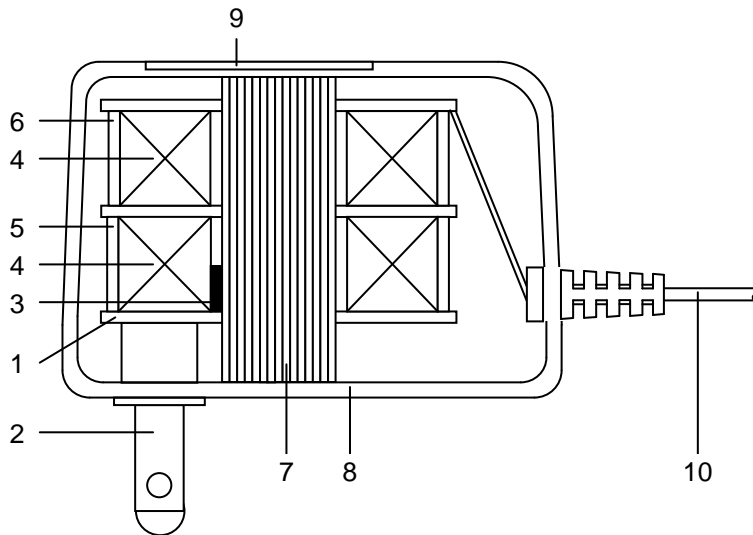

NO.	DESCRIPTION	MATERIAL	SPEC. & Q'TY	MANUFACTURE
1	BOBBIN	70G33L(E41938)		EAST TUNG JUNG PLASTIC HARDWARE CO., LTD. HWA YUE LTD.
2	PRIMARY BLADES	NICKEL PLATING		SPREAD PROFIT ELECTRONIC (DONG CO., LTD.
3	THERMAL CUTOFF	L20 (E142267) A2-F(E140847)	115°C 115°C	JOINT FORCE METAL RESEARCH & CO. AUPO ELECTRONICS LTD.
4	ENAMELED WIRE	POLYURETHANE ENAMELED COPPER WIRE(E85640(S))		FENG CHING METAL CORP. TAI-L ELECTRIC WIRE & CABLE CO., LTD.
5	PRIMARY OUTER WRAP	POLYESTER FILM TAPE (E81174(S))	0.05mm(4T)	QUN YI TAPE (DONGGUAN) CO., LTD. CHYUN YIH TAPE CO., LTD.
6	SECONDARY OUTER WRAP	POLYESTER FILM TAPE (E81174(S))	0.025mm(2T)	QUN YI TAPE (DONGGUAN) CO., LTD. CHYUN YIH TAPE CO., LTD.
7	CORE	SILICON STEEL	0.5mm	SHENZHEN CHUNYUAN STEEL INDUSTRIAL CO., LTD.
8	ENCLOSURE	NORYL SE100X (E161723)		SABIC INNOVATIVE PLASTICS CHINA CO., LTD.
9	NAMEPLATE	PLASTIC FILM	0.2mm	GUANG MING YOU TONG PRINTING FACTORY
10	OUTPUT CORD	FLEXIBLE CORD (E112781)	AWG#22 UL 2468	HUAN WEI ENTERPRISE CO., LTD. MING SHENG ENTERPRISE CO., LTD.

APP.BY \_\_\_\_\_

CHK.BY \_\_\_\_\_

PRE.BY \_\_\_\_\_

## 10.0 NAMEPLATE DRAWING: (UNIT:mm)

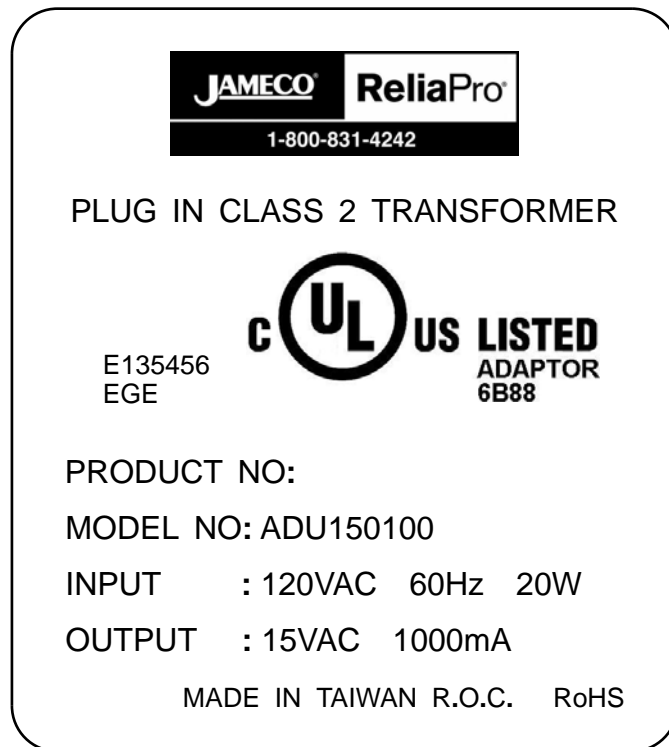

- 1.MATERIAL:Plastic Film
- 2.THICKMESS:0.2
- 3.PRINTING:WORD:BLACK / BACKGROUND: SILVER

APP.BY \_\_\_\_\_

CHK.BY \_\_\_\_\_

PRE.BY \_\_\_\_\_