

Distributed by:



[www.Jameco.com](http://www.Jameco.com) ♦ 1-800-831-4242

The content and copyrights of the attached material are the property of its owner.

Jameco Part Number 230121



# PRODUCT SPECIFICATION

## .093 SERIES PLUG AND RECEPTACLE POWER CONNECTORS

### 1.0 SCOPE

This Product Specification covers the 5.03 mm (.198 inch) centerline connector series using pin and socket terminals terminated with 14 to 24 AWG wire using crimp technology with tin plating.

### 2.0 PRODUCT DESCRIPTION

#### 2.1 PRODUCT NAME AND SERIES NUMBER(S)

<u>PRODUCT NAME</u>	<u>SERIES NUMBER</u>
Plug Housing, 1-circuit	1619-1P
Receptacle Housing, 1-circuit	1619-1R
Plug Housing, 2-circuit	1545-P*
Receptacle Housing, 2-circuit	1545-R*
Plug Housing, 3-circuit	1396-P*
Receptacle Housing, 3-circuit	1396-R*
Plug Housing, 4-circuit (in-line)	1490-P*
Receptacle Housing, 4-circuit (in-line)	1490-R*
Plug Housing, 4-circuit (2 x 2)	2163-P*
Receptacle Housing, 4-circuit (2 x 2)	2163-R*
Plug Housing, 5-circuit	1653-P*
Receptacle Housing, 5-circuit	1653-R*
Plug Housing, 6-circuit	1261-P*
Receptacle Housing, 6-circuit	1261-R*
Plug Housing, 9-circuit	1292-P*
Receptacle Housing, 9-circuit	1292-R*
Plug Housing, 12-circuit	1360-P*
Receptacle Housing, 12-circuit	1360-R*
Socket Terminal, 14-18 AWG	1189
Pin Terminal, 14-18 AWG	1190
Socket Terminal, 18-22 AWG	1380
Pin Terminal, 18-22 AWG	1381
Socket Terminal, 22-24 AWG	2870
Pin Terminal, 22-24 AWG	2871
Socket Terminal, 14-18 AWG, (P-B)	4550
Socket Terminal, 18-22 AWG, (P-B)	2151

#### 2.2 DIMENSIONS, MATERIALS, PLATINGS AND MARKINGS

Housings are molded of UL 94V-2 rated PA66.

Terminals are tin-plated brass or phosphor-bronze.

See appropriate sales drawings for additional information on dimensions, materials, platings and markings.

<u>REVISION:</u> <b>B</b>	<u>ECR/ECN INFORMATION:</u> EC No: <b>UCR#2003-0230</b> DATE: <b>2002 / 08 / 07</b>	<u>TITLE:</u> <b>PRODUCT SPECIFICATION STANDARD .093 SERIES PLUGS &amp; RECEPTACLES</b>	<u>SHEET No.</u> <b>1 of 3</b>
<u>DOCUMENT NUMBER:</u> <b>PS-43660-9999</b>	<u>CREATED / REVISED BY:</u> <b>BWIRKUS 10/4/01</b>	<u>CHECKED BY:</u> <b>BWIRKUS 10/4/01</b>	<u>APPROVED BY:</u> <b>SFRY 10/5/01</b>



# PRODUCT SPECIFICATION

## 2.3 SAFETY AGENCY APPROVALS

UL File #E29179  
CSA File #E29179

## 3.0 APPLICABLE DOCUMENTS AND SPECIFICATIONS

See the appropriate sales drawings for necessary referenced documents and specifications.

## 4.0 RATINGS

### 4.1 VOLTAGE

250 Volts AC (RMS)

### 4.2 CURRENT AND APPLICABLE WIRES

AWG	Circuit Size	Amps
14	3	14
14	9	11
18	3	10
18	9	7
22	3	7
22	9	5

### 4.3 TEMPERATURE

Operating: -55°C to +105°C

## 5.0 PERFORMANCE

### 5.1 ELECTRICAL REQUIREMENTS

ITEM	DESCRIPTION	TEST CONDITION	REQUIREMENT
1	Contact Resistance (Low Level)	Mate connectors: apply a maximum voltage of 20 mV and a current of 20 mA. (Measurement locations in Section 7.0)	10 milliohms MAXIMUM [initial]
2	Dielectric Withstanding Voltage	Mate connectors: apply a voltage of 2000 VAC for 1 minute between adjacent terminals and between terminals to ground.	No breakdown; current leakage < 500 mA
3	Temperature Rise (via Current Cycling)	Mate connectors, measuring the temperature rise at 60 minute intervals during 96 hours of steady state at rated current; followed by 240 hours of current cycling (45 minutes ON and 15 minutes OFF per hour) with measurements made during last 5 minute period of each ON cycle; followed by 96 hours of steady state at rated current with measurements taken at 60 minute intervals.	Temperature rise: +30°C MAXIMUM

REVISION: <b>B</b>	ECR/ECN INFORMATION: EC No: UCR#2003-0230 DATE: 2002 / 08 / 07	TITLE: <b>PRODUCT SPECIFICATION STANDARD .093 SERIES PLUGS &amp; RECEPTACLES</b>	SHEET No. <b>2 of 3</b>
DOCUMENT NUMBER: <b>PS-43660-9999</b>	CREATED / REVISED BY: <b>BWIRKUS 10/4/01</b>	CHECKED BY: <b>BWIRKUS 10/4/01</b>	APPROVED BY: <b>SFRY 10/5/01</b>



# PRODUCT SPECIFICATION

## 5.2 MECHANICAL REQUIREMENTS

ITEM	DESCRIPTION	TEST CONDITION	REQUIREMENT
4	Connector Mate and Unmate Forces	Mate and unmate connector (male to female) at a rate of $25 \pm 6$ mm ( $1 \pm \frac{1}{4}$ inch) per minute for a total of 25 cycles. Initial mate forces to be measured. Unmate forces to be measured after 25 cycles.	<b>15.6 N (3.5 lbf)</b> MAXIMUM insertion force <b>4.4 N (1 lbf)</b> MINIMUM withdrawal force
5	Terminal Retention Force (in Housing)	Axial pullout force on the terminal in the housing at a rate of $25 \pm 6$ mm ( $1 \pm \frac{1}{4}$ inch) per minute.	<b>89 N (20 lbf)</b> MINIMUM retention force
6	Wire Pullout Force (Axial)	Apply an axial pullout force on the wire at a rate of $25 \pm 6$ mm ( $1 \pm \frac{1}{4}$ inch).	MINIMUM pullout forces: 14 AWG <b>178 N (40 lbf)</b> 16 AWG <b>156 N (35 lbf)</b> 18 AWG <b>133 N (30 lbf)</b> 20 AWG <b>89 N (20 lbf)</b> 22 AWG <b>62 N (14 lbf)</b> 24 AWG <b>36 N (8 lbf)</b>
7	Terminal Insertion Force (into Housing)	Apply an axial insertion force on the terminal at a rate of $25 \pm 6$ mm ( $1 \pm \frac{1}{4}$ inch).	<b>22N (5 lbf)</b> MAXIMUM insertion force

## 5.3 ENVIRONMENTAL REQUIREMENTS

ITEM	DESCRIPTION	TEST CONDITION	REQUIREMENT
8	Thermal Cycling	Mate connectors; expose to temperature cycling between $-25^{\circ}\text{C}$ and $70^{\circ}\text{C}$ for 500 cycles with a dwell time of 30 minutes at each extreme. Measurements to be taken initially and after every 100 cycles.	<b>10 milliohms</b> MAXIMUM (change from initial) & Visual: No Damage

## 6.0 PACKAGING

Parts shall be packaged to protect against damage during handling, transit and storage. See the appropriate sales drawings for additional information on packaging requirements.

REVISION: <b>B</b>	ECR/ECN INFORMATION: EC No: <b>UCR#2003-0230</b> DATE: <b>2002 / 08 / 07</b>	TITLE: <b>PRODUCT SPECIFICATION STANDARD .093 SERIES PLUGS &amp; RECEPTACLES</b>	SHEET No. <b>3 of 3</b>
DOCUMENT NUMBER: <b>PS-43660-9999</b>	CREATED / REVISED BY: <b>BWIRKUS 10/4/01</b>	CHECKED BY: <b>BWIRKUS 10/4/01</b>	APPROVED BY: <b>SFRY 10/5/01</b>

# PLUG

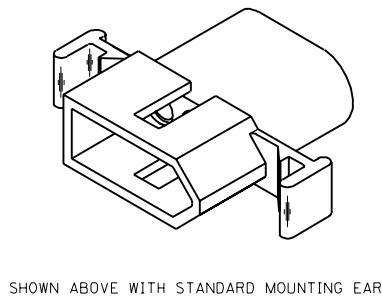
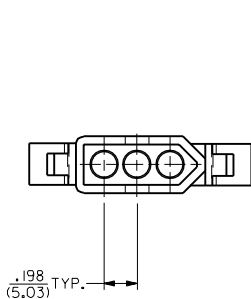
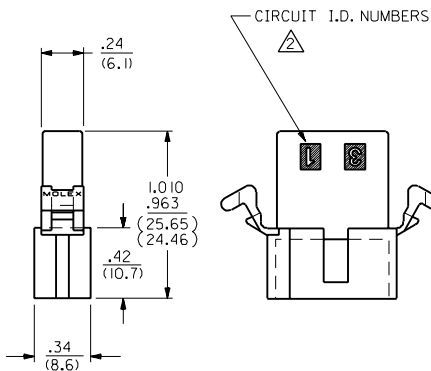
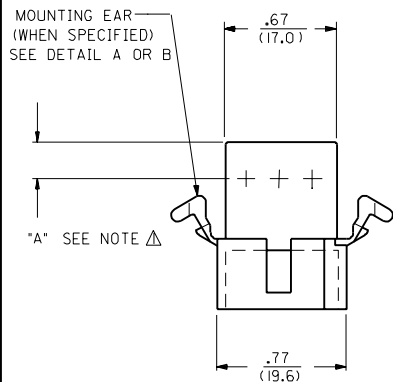
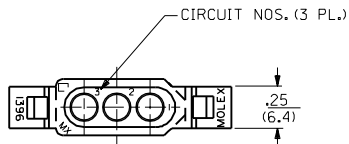

# RECEPTACLE

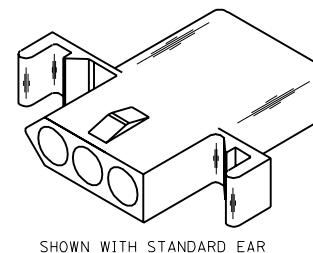
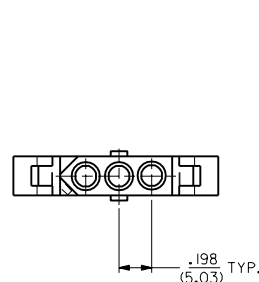
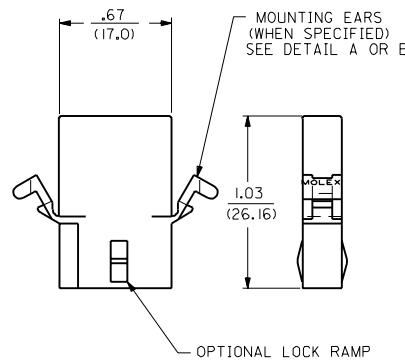
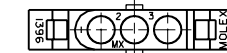
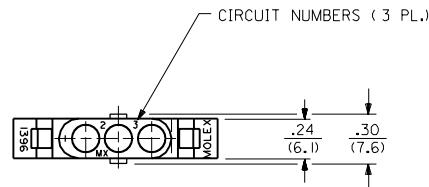

NOTES:  
 Δ DIMENSION FROM THE BACK OF HOUSING TO THE END OF THE BRUSH ON THE WIRE INSERTED INTO THE HOUSING  
 DIM "A" = .256/6.50 FOR 42477 & 42478 TERMINALS  
 .216/5.49 FOR ALL OTHER .093 TERMINALS  
 DIM "B" = .377/9.58 FOR 42477 & 42478 TERMINALS  
 .337/8.56 FOR ALL OTHER .093 TERMINALS

Y3	REVISED PER UCR2000-05B3 3/1/00 DDB
Y2	REMOVE -R3, -R5 VER. PER ECON #UG 1479 6-10-96 RW
Y1	X-REMOVE 1396-R4 ECR U3 1583 GC 10/26/93 RW
Y	ADD CKT. I.D. #'S PER ECR U3 0683 GC 5/4/93 RW
X	REV MAT'L SPECS. ECR U2-1491 10-08-92 A.GUZIK
W1	ADD -D VERSIONS. ECR U1 1106 GC 7/25/91 RW
W	REVISE ON CAD ECR #UB 1381 JJS 4-24-88 RW
2	Y2
1	Y3
MFG. SH.	REV. LTR.
REVISE ONLY ON CAD SYSTEM	

DIMENSIONS SHOWN METRIC (INCH) UNLESS OTHERWISE SPECIFIED TOLERANCES ANGULAR ± 1/2°

	INCH	METRIC
3 PLACE	± .010	---
2 PLACE	± .014	± 0.25
1 PLACE	---	± 0.36

DRAFT WHERE APPLICABLE MUST REMAIN WITHIN DIMENSIONS

DRWG. BY: RAS  
 CHKD. BY: JUS  
 APP'D. BY: RAS

FILE NAME: S1396.3X1.DWG  
 SCALE: 2 : 1

TITLE: .093/(2.36) HOUSING, PLUG & RECEPTACLE  
 3 CIRCUIT, 198/(5.03) C

PART NO.: L15LEJLL  
 MOLEX INCORPORATED  
 60532 U.S.A.

SHEET NO.: 1 of 2  
 DATE: 4 / 3 / 88

DRWG. NO.: SD-1396-•

THIS DRAWING CONTAINS INFORMATION THAT IS PROPRIETARY TO MOLEX INC. AND SHOULD NOT BE USED WITHOUT WRITTEN PERMISSION. CP

13 12 11 10 9 8 7 6 5 4 3 2 1

PLUG		RECEPTACLE	
ORDER NO.	ENG. NO.	ORDER NO.	ENG. NO.
03-09-2031	I396-P	03-09-1031	I396-R
03-09-2032	I396-P1	03-09-1032	I396-R1
03-09-7032	I396-P1BK	03-09-1033	I396-R2
03-09-7031	I396-PBK	03-09-6033	I396-R2BK
PRELIMINARY	I396-P-B	03-09-6032	I396-R1BK
		03-09-6031	I396-RBK
		PRELIMINARY	I396-R-B
		PRELIMINARY	I396-R1-B
		03-09-1081	I396-R4

**LEGEND:**

I396-\*\*\*\*\*

P = PLUG  
R = RECEPTACLE

BLANK = WITH STANDARD EARS  
 1 = WITHOUT EARS  
 2 = RECEPTACLE WITHOUT EARS, WITHOUT LOCK RAMP  
 3 = PLUG ONLY, W/ SIDE MOUNT (SEE SD-I396-P3)  
 4 = WITH PREBENT EARS

COLOR: BLANK=NATURAL COLOR  
 AM=AMBER BK=BLACK BU=BLUE  
 BN=BROWN CY=GRAY GN=GREEN  
 OR=ORANGE RD=RED YW=YELLOW

BLANK = NYLON 6/6, 94V-2  
 B = NYLON TYPE 6/6, 94V-2, UV STABILIZED

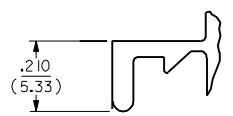

**DETAIL A**  
STANDARD MOUNTING EAR  
(SCALE 4:1)

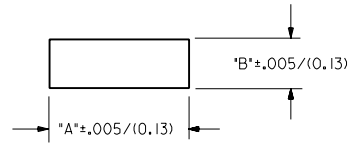
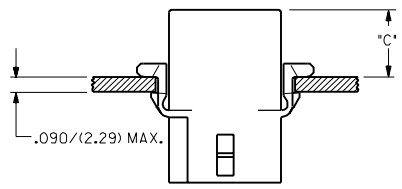

RECOMMENDED PANEL MOUNTING HOLE

HOUSING	DIM. "A"	DIM. "B"	"C" PREBENT EAR	"C" STANDARD EAR
PLUG	.933/(23.70)	.375/(9.53)	.40/(10.2)	.38/(9.7)
RECEPT.	.830/(21.08)	.312/(7.92)	.41/(10.4)	.39/(9.9)

NOTES:  
 1. MOLEX PRODUCT SPEC 02-09 APPLIES.  
 2. CIRCUIT I.D. NUMBERS ON SIDE OF HOUSING APPEAR ON PARTS FROM TOOLS BUILT AFTER 5/4/93.

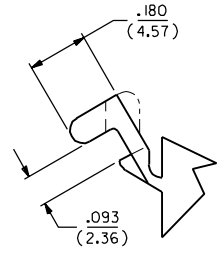
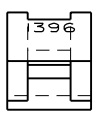

**DETAIL B**  
PREBENT MOUNTING EAR  
(SCALE 4:1)

I396

I396

A

A

DIMENSIONS SHOWN (METRIC) INCH		▽=0 ▽=0		REVISE ONLY ON CAD SYSTEM	
UNLESS OTHERWISE SPECIFIED TOLERANCES ANGLES ARE 1/2°					
INCH		METRIC			
3 PLACE	± .010	---			
2 PLACE	± .014	± 0.25			
1 PLACE	---	± 0.35			
DRAFT WHERE APPLICABLE MUST REMAIN WITHIN DIMENSIONS					
DRWG. BY: JJS	CHK'D. BY: RW	FILE NAME: S13962X2	SCALE: :	THIS DRAWING CONTAINS INFORMATION THAT IS PROPRIETARY TO MOLEX INC. AND SHOULD NOT BE USED WITHOUT WRITTEN PERMISSION.	
APP'D. BY: RAS	SCALE: :	PART NO. SD-1396-*		DATE: 4/8/88	
LTR. REVISIONS		LTR. REVISIONS		CP C	

13 12 11 10 9 8 7 6 5 4 3 2 1

DWG. NO.  
SD-1396-002

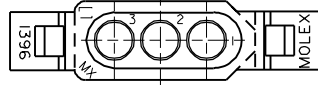

MT'G EARS (表参照)  
参照 DETAIL A

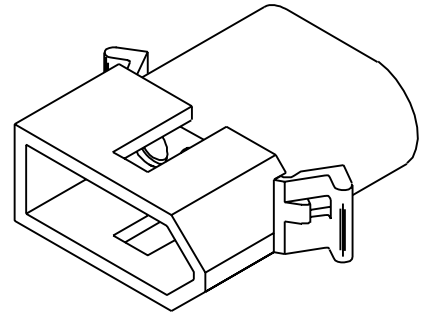
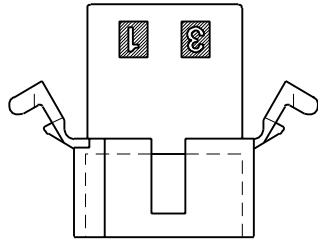
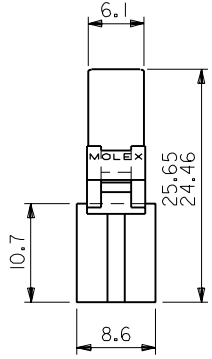
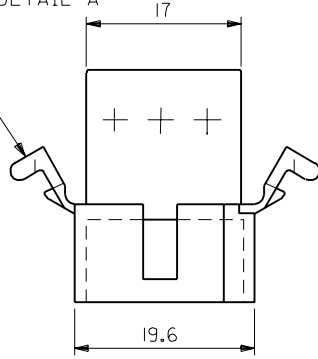

PLUG

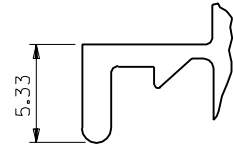
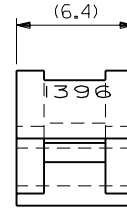

DETAIL A  
(SCALE 4:1)

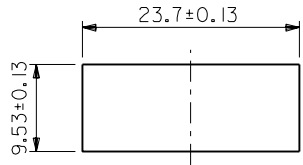
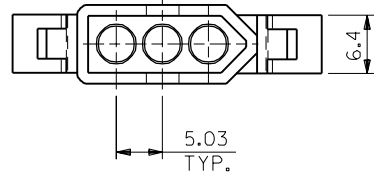

パネル取付穴寸法  
(パネル厚 2.29最大)

1396P1	03-09-2032	無	WITHOUT
1396P	03-09-2031	有	WITH
ENG. NO.	EDP NO.		MT'G EARS

DO NOT SCALE DRAWING

EC NO. DRWN: CHK: APPR:	EC NO. DRWN: CHK: APPR:	EC NO. DRWN: CHK: APPR:	EC NO. DRWN: CHK: APPR:	EC NO. DRWN: CHK: APPR:
RELEASED				
EC NO. JC2001-0078				
DRWN: K.KOHAMA 00/08/28				
CHK: T.YAMAGUCHI				
APPR: M.FUKUSHIMA				

MATERIAL 材料	NYLON66 94V-2
FINISH 仕上り	
WIRE RANGE 適用電線範囲	
INS. RANGE 被覆外径	

GENERAL TOLERANCES: (UNLESS SPECIFIED) 一般公差	
10 UNDER 未満	+0.25 ±0.25
10 OVER 以上 30 UNDER 未満	+0.3 ±0.25
30 OVER 以上	+0.35 ±0.3
ANGLE 角度	+3°

MODEL NO.	03-09-2***	DIMENSIONS:	SHT	REV
SCALE	2:1	DESIGN UNITS <input checked="" type="checkbox"/> mm <input type="checkbox"/> INCH	<input type="checkbox"/> mm <input type="checkbox"/> mm <input checked="" type="checkbox"/> mm ONLY	REVISE ON CAD ONLY
THIRD ANGLE PROJECTION				
DRAWN BY & DATE K.KOHAMA 00/08/28	TITLE: 3 CIRCUITS PLUG HSG (0.093 DIA TERMINAL)			
CHECKED BY & DATE T.YAMAGUCHI 00/08/28	APPROVED BY & DATE M.FUKUSHIMA 00/08/28			
CAD FILENAME 1396002.S01	MATERIAL NO. SEE NOTES	DRAWING NO. SD-1396-002	SHEET NO. 1 OF 1	
THIS DRAWING CONTAINS INFORMATION THAT IS PROPRIETARY TO MOLEX INCORPORATED AND SHOULD NOT BE USED WITHOUT WRITTEN PERMISSION.				SIZE B

EN-02J(097) MXJ-54

1396002.S01