

Distributed by:



www.Jameco.com ♦ 1-800-831-4242

The content and copyrights of the attached material are the property of its owner.

FEATURES AND SPECIFICATIONS

Features and Benefits

- Standard cantilever terminal
- Cantilever design provides high contact pressure
- Wiping action cleans oxides when connector is mated
- 2759 Series is Brass
- 6459 Series is Phosphor Bronze

Reference Information

Product Specification: PS-10-07
 Packaging: Bag or reel
 Tooling Information: See crimp tooling section
 UL File No.: E29179
 CSA File No.: LR19980
 Use With: [2695](#), [5051](#), 6745 and 41895 housings
 Designed In: Inches

Electrical

Voltage: 250V
 Current: 6459—4.0A
 2759—2.5A
 Contact Resistance: 20mΩ max.
 Dielectric Withstanding Voltage: 1500V
 Insulation Resistance: 50K MΩ min.

Mechanical

Wire Pull-Out Force:

Wire Gauge (AWG)	22	24	26	28	30
Pull-Out Force (lb)	10	8	6	4	3

Mating Force: 255g max.
 Unmating Force: 50g min.
 Normal Force: 200g min.

Physical

Contact: 6459—Phosphor Bronze
 2759—Brass
 Plating: See Table
 Wire Accommodation: 22 to 30 AWG
 Insulation Range: 1.58mm (.062") diameter max.



2.54mm (.100") Pitch KK[®] Crimp Terminal

2759/6459

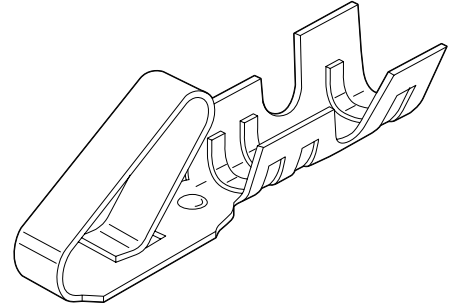

2.54mm (.100") Pitch

CATALOG DRAWING (FOR REFERENCE ONLY)

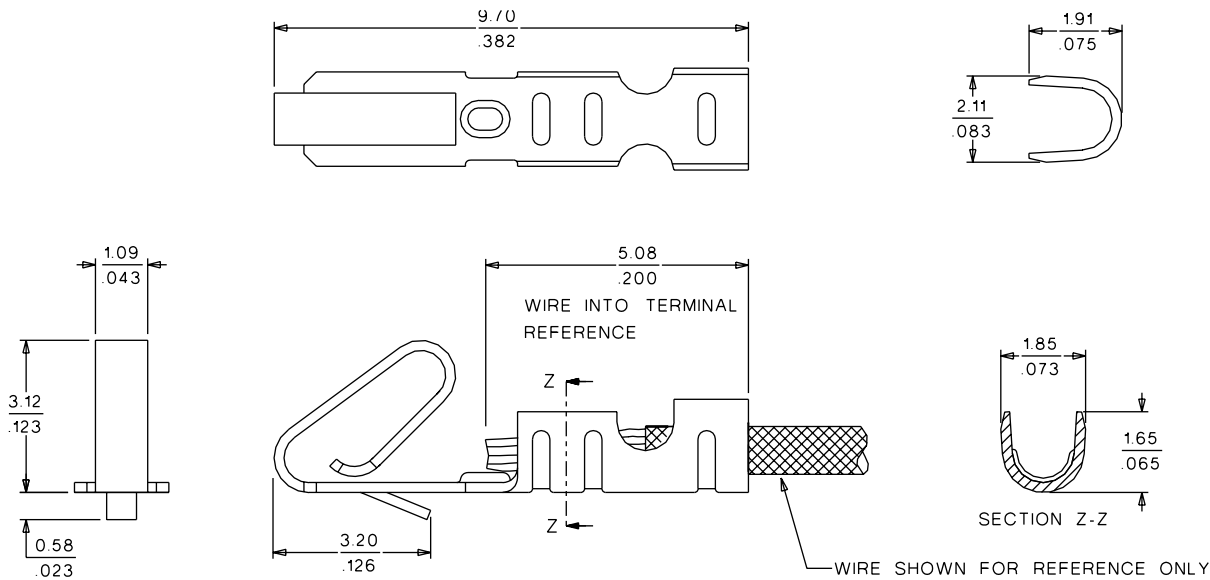

Note: 2759 shown

ORDERING INFORMATION AND DIMENSIONS

Contact	Order No.						Wire Gauge (AWG)	Insulation OD
	Tin Plating		15μ" Gold Plating		15μ" Selective Gold Plating			
	Bag	Reel	Bag	Reel	Bag	Reel		
Brass	• 08-50-0114	• 08-50-0113	• 08-56-0110	• 08-56-0109	• 08-55-0102	• 08-55-0101	22-30	1.57 (.062)
Phosphor Bronze	• 08-52-0123	• 08-52-0101	• 08-65-0814	• 08-65-0813	• 08-65-0816	• 08-65-0815	22-30	1.57 (.062)

• US Standard Product, available through Molex franchised distributors



PRODUCT SPECIFICATION

1.0 SCOPE

This Product Specification covers the 2.54 mm (.100 inch) centerline (pitch) 0.64 mm (.025) square pin headers when mated with either printed circuit board (PCB) connectors or connectors terminated with 22 to 28 AWG wire using crimp technology.

2.0 PRODUCT DESCRIPTION

2.1 PRODUCT NAME AND SERIES NUMBERS

Crimp Terminals: 2759, 41572, 6459

Crimp Housings: 2695

PCB Connectors: 4455, 42625

Headers: 4030, 4094, 6373, 7478, 42225, 42226, 42227, 42228, 42152, 42153, 42375, 42376, 42377, 42624.

Other products conforming to this specification are noted on the individual drawings.

2.2 DIMENSIONS, MATERIALS, PLATINGS AND MARKINGS

Terminal Material: Brass or Phos. Bronze (for Max performance use phos bronze material.)

Housing: Nylon or Polyester

Pins: Brass or Phos. Bronze

For more information on dimensions, materials, and plating see the individual drawings.

2.3 SAFETY AGENCY APPROVALS

UL File Number E29179

CSALR19980

3.0 APPLICABLE DOCUMENTS AND SPECIFICATIONS

None

4.0 RATINGS

4.1 VOLTAGE

250 Volts

4.2 CURRENT AND APPLICABLE WIRES (Current is dependent on connector size, contact material, plating, ambient temperature, printed circuit board characteristics and related factors. Actual current rating is application dependent and should be evaluated for each application.)

AWG	Amps (Max)	Outside Insulation Diameter
22	4.00	See Drawings
24	3.75	See Drawings
26	3.50	See Drawings
28	3.00	See Drawings

4.3 TEMPERATURE (ambient + 30° temp rise)

Operating: 0°C to +75°C

Nonoperating: - 40°C to +105°C

REVISION: P	ECR/ECN INFORMATION: EC No: UCR2002-0299 DATE: 2001 / 09 / 18	TITLE: PRODUCT SPECIFICATION .100 CENTER KK CONNECTORS	SHEET No. 1 of 5
DOCUMENT NUMBER: PS-10-07	CREATED / REVISED BY: SAMIEC	CHECKED BY: MUELLER	APPROVED BY: MARGULIS



PRODUCT SPECIFICATION

5.0 PERFORMANCE

5.1 ELECTRICAL REQUIREMENTS

DESCRIPTION	TEST CONDITION	REQUIREMENT
Contact Resistance (Low Level)	Mate connectors: apply a maximum voltage of 20 mV and a current of 100 mA.	10 milliohms MAXIMUM [initial]
Contact Resistance of Wire Termination (Low Level)	Terminate the applicable wire to the terminal and measure wire using a voltage of 20 mV and a current of 100 mA.	2 milliohms MAXIMUM [initial]
Insulation Resistance	Unmate & unmount connectors: apply a voltage of 500 VDC between adjacent terminals and between terminals to ground.	1000 Megohms MINIMUM
Dielectric Withstanding Voltage	Unmate connectors: apply a voltage of {two times the rated voltage plus 1000 volts} VAC for 1 minute between adjacent terminals and between terminals to ground.	No breakdown
Capacitance	Measure between adjacent terminals at 1 MHz.	2 picofarads MAXIMUM
Temperature Rise (via Current Cycling)	Mate connectors: measure the temperature rise at the rated current after: 1) 96 hours (steady state) 2) 240 hours (45 minutes ON and 15 minutes OFF per hour) 3) 96 hours (steady state)	Temperature rise: +30°C MAXIMUM

REVISION: P	ECR/ECN INFORMATION: EC No: UCR2002-0299 DATE: 2001 / 09 / 18	TITLE: PRODUCT SPECIFICATION .100 CENTER KK CONNECTORS	SHEET No. 2 of 5
DOCUMENT NUMBER: PS-10-07	CREATED / REVISED BY: SAMIEC	CHECKED BY: MUELLER	APPROVED BY: MARGULIS



PRODUCT SPECIFICATION

5.2 MECHANICAL REQUIREMENTS

DESCRIPTION	TEST CONDITION	REQUIREMENT
Connector Mate and Unmate Forces	Per circuit when mated to an .025 Sq. pin. Mate and unmate connector (male to female) at a rate of 25 ± 6 mm ($1 \pm \frac{1}{4}$ inch) per minute.	1.95 N (0.438 lbf) MAXIMUM insertion force & 0.56 N (0.125 lbf) MINIMUM withdrawal force
Terminal Retention Force (in Housing)	Axial pullout force on the terminal in the housing at a rate of 25 ± 6 mm ($1 \pm \frac{1}{4}$ inch) per minute. (Forces will change with platings and materials.)	17.8 N (4.0 lbf) MINIMUM withdrawal force
Terminal Insertion Force (into Housing)	Apply an axial insertion force on the terminal at a rate of 25 ± 6 mm ($1 \pm \frac{1}{4}$ inch). (Forces will change with platings and materials.)	6.67 N (1.5 lbf) MAXIMUM insertion force
Durability	Mate connectors up to 25 cycles at a maximum rate of 10 cycles per minute prior to Environmental Tests.	10 milliohms MAXIMUM (change from initial)
Vibration (Random)	Mate connectors and vibrate per EIA 364-28, test condition VII.	10 milliohms MAXIMUM (change from initial) & Discontinuity < 1 microsecond
Shock (Mechanical)	Mate connectors and shock at 50 g's with $\frac{1}{2}$ sine wave (11 milliseconds) shocks in the $\pm X, \pm Y, \pm Z$ axes (18 shocks total).	10 milliohms MAXIMUM (change from initial) & Discontinuity < 1 microsecond
Wire Pullout Force (Axial)	Apply an axial pullout force on the wire at a rate of 25 ± 6 mm ($1 \pm \frac{1}{4}$ inch). (For maximum performance use Molex application tooling with stranded tinned copper wire)	22 awg = 44 N (10 lbf) 24 awg = 35 N (8 lbf) 26 awg = 26 N (6 lbf) 28 awg = 17 N (4 lbf) 30 awg = 13 N (3 lbf)
Normal Force	Apply a perpendicular force.	2.94 N (300 grams) average

REVISION: P	ECR/ECN INFORMATION: EC No: UCR2002-0299 DATE: 2001 / 09 / 18	TITLE: PRODUCT SPECIFICATION .100 CENTER KK CONNECTORS	SHEET No. 3 of 5
DOCUMENT NUMBER: PS-10-07	CREATED / REVISED BY: SAMIEC	CHECKED BY: MUELLER	APPROVED BY: MARGULIS



PRODUCT SPECIFICATION

5.3 ENVIRONMENTAL REQUIREMENTS

DESCRIPTION	TEST CONDITION	REQUIREMENT										
Shock (Thermal)	Mate connectors; expose to 5 cycles of: <table border="1"> <thead> <tr> <th>Temperature °C</th> <th>Duration (Minutes)</th> </tr> </thead> <tbody> <tr> <td>-40 +0/-3</td> <td>30</td> </tr> <tr> <td>+25 ±10</td> <td>5 MAXIMUM</td> </tr> <tr> <td>+105 +3/-0</td> <td>30</td> </tr> <tr> <td>+25 ±10</td> <td>5 MAXIMUM</td> </tr> </tbody> </table>	Temperature °C	Duration (Minutes)	-40 +0/-3	30	+25 ±10	5 MAXIMUM	+105 +3/-0	30	+25 ±10	5 MAXIMUM	10 milliohms MAXIMUM (change from initial) & Visual: No Damage
Temperature °C	Duration (Minutes)											
-40 +0/-3	30											
+25 ±10	5 MAXIMUM											
+105 +3/-0	30											
+25 ±10	5 MAXIMUM											
Thermal Aging	Mate connectors; expose to: 96 hours at 105 ± 2°C	10 milliohms MAXIMUM (change from initial]) & Visual: No Damage										
Humidity (Steady State)	Mate connectors: expose to a temperature of 40 ± 2°C with a relative humidity of 90-95% for 96 hours. Note: Remove surface moisture and air dry for 1 hour prior to measurements.	10 milliohms MAXIMUM (change from initial) & Dielectric Withstanding Voltage: No Breakdown at 500 VAC & Insulation Resistance: 1000 Megohms MINIMUM & Visual: No Damage										
Humidity (Cyclic)	Mate connectors: cycle per EIA-364-31: 24 cycles at temperature 25 ± 3°C at 80 ± 5% relative humidity and 65 ± 3°C at 50 ± 5% relative humidity; dwell time of 1.0 hour; ramp time of 0.5 hours. {Note: Remove surface moisture and air dry for 1 hour prior to measurements.}	10 milliohms MAXIMUM (change from initial) & Dielectric Withstanding Voltage: No Breakdown at 500 VAC & Insulation Resistance: 1000 Megohms MINIMUM & Visual: No Damage										
Solderability	Per SMES-152	Solder coverage: 95% MINIMUM (per SMES-152)										

REVISION: P	ECR/ECN INFORMATION: EC No: UCR2002-0299 DATE: 2001 / 09 / 18	TITLE: PRODUCT SPECIFICATION .100 CENTER KK CONNECTORS	SHEET No. 4 of 5
DOCUMENT NUMBER: PS-10-07	CREATED / REVISED BY: SAMIEC	CHECKED BY: MUELLER	APPROVED BY: MARGULIS



PRODUCT SPECIFICATION

5.3 ENVIRONMENTAL REQUIREMENTS

DESCRIPTION	TEST CONDITION	REQUIREMENT
Solder Resistance	Dip connector terminal tails in solder: Solder Duration: 5 ± 0.5 seconds; Solder Temperature: $230 \pm 5^\circ\text{C}$	Visual: No Damage to insulator material
Salt Spray	Mate connectors: Duration: 48 hours exposure; Atmosphere: salt spray from a 5% solution; Temperature: $35 +1/-2^\circ\text{C}$	10 milliohms MAXIMUM (change from initial) & Visual: No Damage
Cold Resistance	Mate connectors: Duration: 96 hours; Temperature: $-40 \pm 3^\circ\text{C}$	10 milliohms MAXIMUM (change from initial) & Visual: No Damage
Corrosive Atmosphere: Flowing Mixed Gas (FMG)	Mate connectors: Test per EIA-364-65, method 2A	10 milliohms MAXIMUM (change from initial) & Visual: No Damage

6.0 PACKAGING

Parts shall be packaged to protect against damage during handling, transit and storage.

7.0 GAGES AND FIXTURES

8.0 OTHER

REVISION: P	ECR/ECN INFORMATION: EC No: UCR2002-0299 DATE: 2001 / 09 / 18	TITLE: PRODUCT SPECIFICATION .100 CENTER KK CONNECTORS	SHEET No. 5 of 5
DOCUMENT NUMBER: PS-10-07	CREATED / REVISED BY: SAMIEC	CHECKED BY: MUELLER	APPROVED BY: MARGULIS

CARRIER VIEW

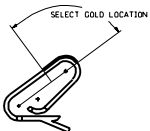
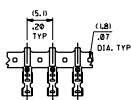

CRIMP DETAIL

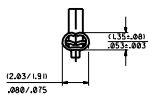

CRIMPED TERMINAL 2759-IP90JILC IS USED WITHOUT WIRE AND IS INSERTED INTO HOUSING TO PROVIDE TENSION WHEN ASSEMBLED TO HEADERS DURING SHIPMENT.

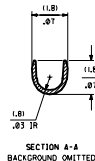
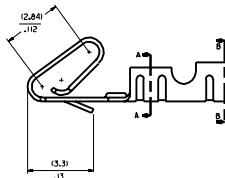
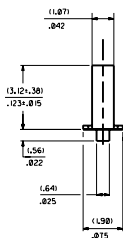
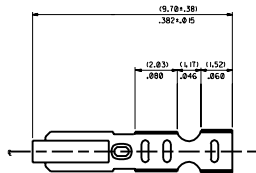
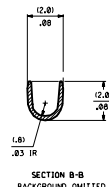
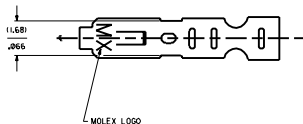
SECTION A-A
BACKGROUND OMITTEDSECTION B-B
BACKGROUND OMITTED

2759-(****)

FORM
L=LOOSE
C=LOOSE CRIMPED
A=CHAIN PER ES-339-A
B=CHAIN PER ES-339-B

PLATING

PER SDES-88
(402) ELECTRO TIN .000300/.000200 OVER
 .000150/.000100 COPPER
(555) SELECT GOLD .000025/.000015 OVER
 .000000/.000030 NICKEL
(558) SELECT GOLD .000040/.000030 OVER
 .000100/.000050 NICKEL
(561) SELECT GOLD .000040/.000030 OVER
 .000100/.000050 NICKEL WITH GOLD FLASH
(P914) HOT TIN-LEAD DIP .000100/.000040
(P915) HOT TIN-LEAD DIP .000250/.000100

NOTES

- CRIMP IS FOR 22-30 GA WIRE, WITH .062 DIA INSULATION MAX.
- INSERTION FORCE OF TERMINAL INTO .100 ϵ CONNECTOR IS 2.5 LBS. MAX
- TERMINALS MUST RETAIN 8 LBS PULL FOR 1 MIN. IN KK .100 ϵ HOUSING.
- GAP REQUIRED ON UNPLATED TERMINALS ONLY.
- MATERIAL .0008 \pm .0004 THICK BRASS, PER ES-24C-6.
- DIMENSIONS GIVEN ACROSS CENTERLINES ARE SYMMETRICAL ABOUT THOSE CENTERLINES WITHIN HALF THE TOTAL TOLERANCE.
- CODE LETTER PRECEDING PART NO. DESIGNATES MANUFACTURING LOCATION 1=IRELAND
- THIS PART CONFORMS TO PRODUCT SPEC 0-07

DESIGNED BY	DATE	REV. 1	REV. 1	REV. 1
DR. J. B. B.	11-29-90			
CHKD. J. B. B.				
APP. J. B. B.				
DATE	TIME	DATE	TIME	DATE
11-29-90				
MOLEX INCORPORATED	CRIMP TERMINAL	22-30 GA WIRE	SD-2759	
MOLEX INCORPORATED	CRIMP TERMINAL	22-30 GA WIRE	SD-2759	

2759-(****):-----		2759-(****):-----		2759-(****):-----		2759-(****):-----		2759-(****):-----	
PART NO.	ENG. NO.	PART NO.	ENG. NO.	PART NO.	ENG. NO.	PART NO.	ENG. NO.	PART NO.	ENG. NO.
08-51-0101	2759-(999)B								
08-51-0102	2759-(999)H								
08-55-0101	2759-(555)B								
08-55-0102	2759-(555)H								
08-55-0126	2759-(555)A								
08-56-0109	2759-(560)B								
08-56-0110	2759-(560)H								
08-50-0113	2759-(P913)B								
08-50-0114	2759-(P913)H								
08-50-0124	2759-(P913)C								
08-51-0108	2759-(122)B								
1 08-50-0274	2759-(P914)B								
1 08-50-0275	2759-(P914)H								
1 08-50-0273	2759-(P914)A								
08-55-0130	2759-(558)B								
08-55-0131	2759-(558)H								
08-50-0151	2759-(P102)H								
08-50-0148	2759-(P102)H								
08-50-0160	2759-(1102)H								
08-50-0159	2759-(1102)H								

SEE SHEET 1.....	SEE SHEET 1.....	DIMENSIONS SHOWN UNLESS NOTED OTHERWISE DECIMALS TO 3 DECIMALS UNLESS NOTED OTHERWISE UNLESS OTHERWISE SPECIFIED 1. DIMENSIONS IN INCH 2. DIMENSIONS IN MILLIMETER	TITLE CRIMP TERMINAL 22-30 GA. WIRE
SEE SHEET 1.....	SEE SHEET 1.....		MOLER INCORPORATED 30-2159 DATE: 10/28/97 DRAWN BY: CHABIS CHECKED BY: KKK PART NO. 30-2159 SCALE: 1:1 SHEET NO. 1 TOTAL SHEETS: 1
L.T.R. REVISIONS	L.T.R. REVISIONS	SHEET NO. 1 TOTAL SHEETS: 1 SCALE: 1:1 DATE: 10/28/97	REVISE ONLY ON CAD SYSTEM DATE: 10/28/97 DRAWN BY: CHABIS CHECKED BY: KKK