

Distributed by:



www.Jameco.com ♦ 1-800-831-4242

The content and copyrights of the attached material are the property of its owner.

USING THE L6506 FOR CURRENT CONTROL OF STEPPING MOTORS

by Thomas Hopkins

Chopper-type current control circuits improve the performance of motor drives. This note shows how this can be done simply using the L6506 current controller IC.

The L6506 is a linear integrated circuit designed to sense and control the current in stepping motors and other similar devices. When used in conjunction with power stages like the L293, L298N, or L7180 the chip set forms a constant current drive for inductive loads and performs all the interface functions from the control logic through the power stage.

The L6506 may be used with either two phase bipolar or four phase unipolar motor configurations. The circuit in figure 1 shows the L6506 used in conjunction with the L298N in a 2 phase bipolar stepper motor application. The circuit in figure 2 implements a similar 4 phase unipolar application.

CURRENT CONTROL LOGIC

In these two circuits, the L6506 is used to sense and control the current in each of the load windings. The

current is sensed by monitoring the voltage across a sense resistor (R_{sense}) and using a Pulse Width Modulated control to maintain the current at the desired value.

An on-chip oscillator drives the dual chopper and sets the operating frequency. An RC network on pin 1 sets the operating frequency, which is given by the equation :

$$f \approx \frac{1}{0.69 R_1 C_1} \quad (1)$$

for $R_1 > 10 \text{ K}\Omega$

The oscillator provides pulses to set the two flip-flops, which in turn cause the outputs to activate the power actuator. Once the outputs have been activated the current in the load starts to increase, limited by the inductive characteristic of the load.

Figure 1 : Application Circuit for Bipolar 2 Phase Stepper Motor.

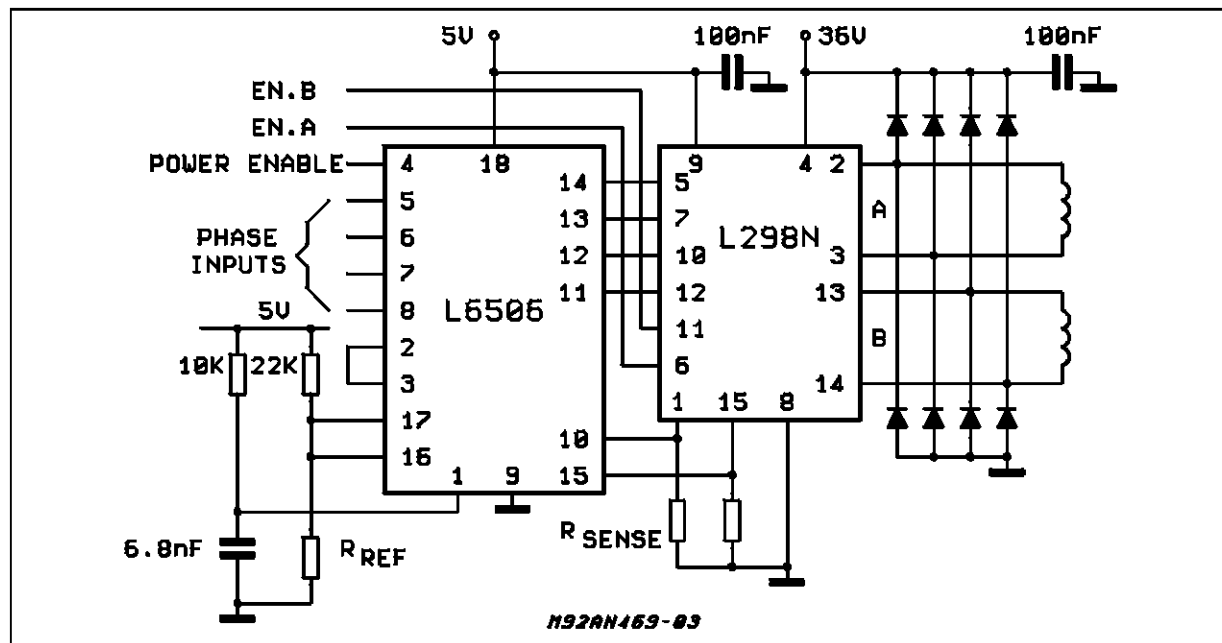

APPLICATION NOTE

Figure 2 : Application Circuit for Unipolar 4 Phase Stepper Motor.

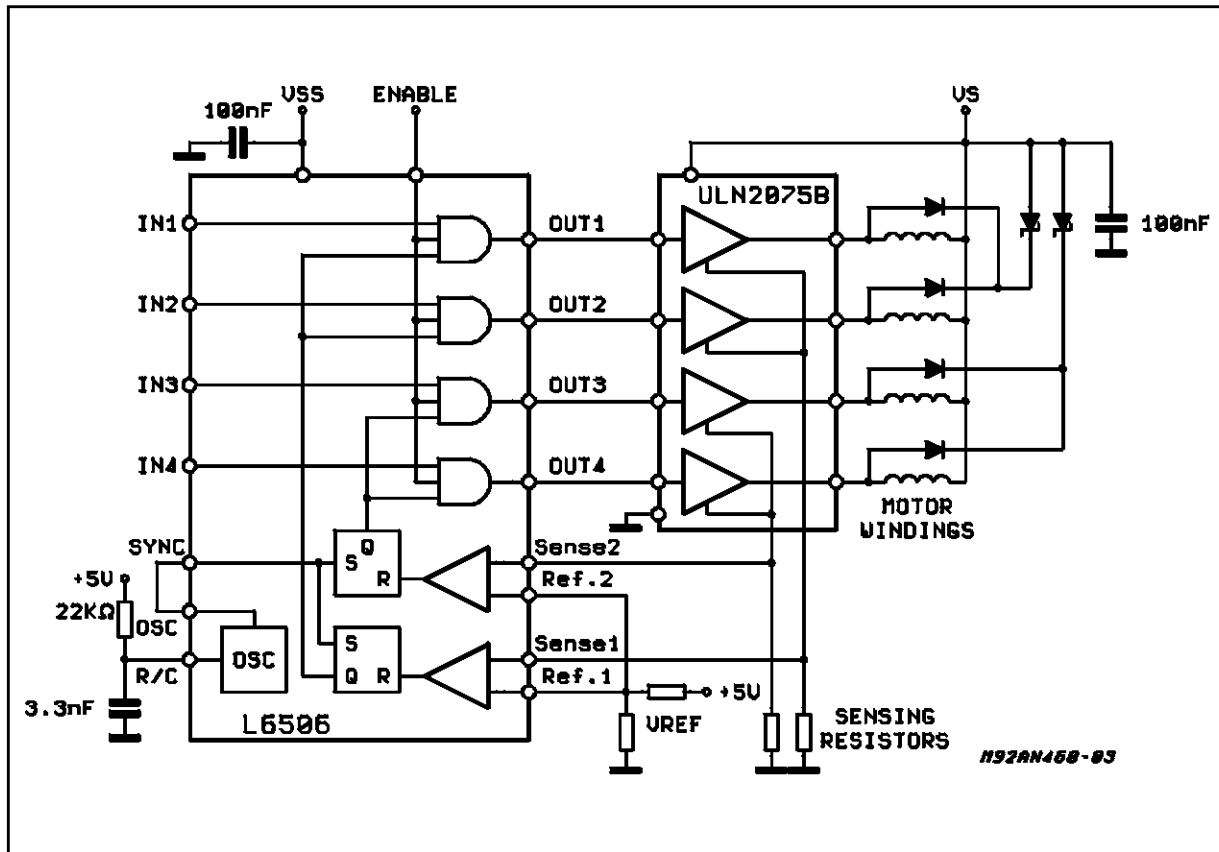

When the current in the load winding reaches the programmed peak value, the voltage across the sense resistor (R_{sense}) is equal to reference voltage input (V_{ref}) and the corresponding comparator resets its flip-flop. This interrupts the drive and allows the current to decay through a recirculating path until the next oscillator pulse occurs. The peak current in each winding is programmed by selecting the value of the sense resistor and V_{ref} and is given by the equation :

$$I_{peak} = \frac{V_{ref}}{R_{sense}} \quad (2)$$

The minimum output pulse width is determined by the pulse width of the oscillator, or other signal applied to the sync input. The internal oscillator is designed to provide narrow pulses to the sync input but the pulse width should be considered carefully. In some applications it is desirable to set the pulse width of this sync pulse to be just longer than the turn on delay time of the actuator stage. This may be useful in systems where the switching noise or recovery current of the catch diodes, which passes through the sense resistor, causes the comparator to sense a current above the peak current. By ma-

king the sync pulse wide enough to hold the flip-flop set at the time the switching transient occurs will cause the device to ignore this false data.

When the internal oscillator is used the pulse width can be modified by changing the value of the capacitor on pin 1.

Increasing the capacitance will widen the pulse width.

The L6506 may be used with either a bridge driver, as shown in figure 1, for bipolar motors or a quad darlington array, as shown in figure 2, for 4 phase unipolar motors. For either configuration, half step may be implemented using the 4 phase inputs with the input waveforms shown in figure 3.

The recirculation path for the motor current is through a catch diode for unipolar motors, or a catch diode and one of the lower transistors of the bridge for bipolar motors. Both of these implementations produce a low ripple current since the voltage across the motor during the recirculation time is much less than the power supply voltage. Figure 4 shows the ripple current for bipolar motor applications using the L6506 and the L298N.

Figure 3 : Input Signal for Stepper Motor Drive.

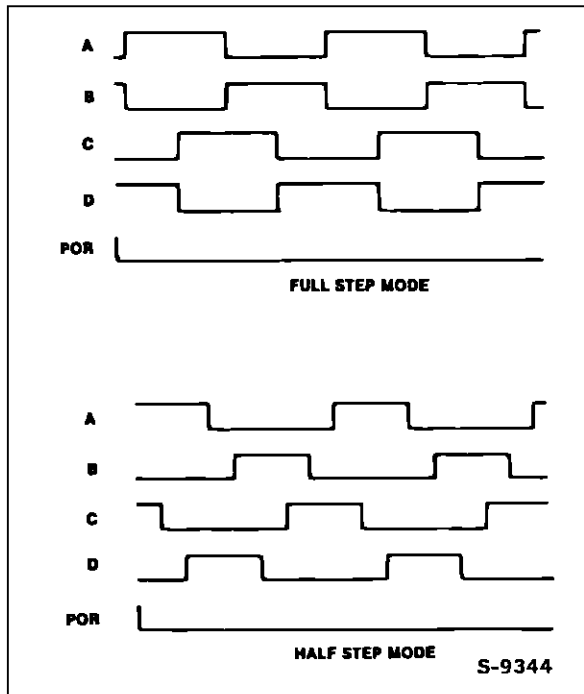

When implementing a half step drive, both outputs of the L6506 will be low during the half step of one phase. This means a very long time is required for the current in the "off" winding to decay when driving bipolar motors.

Alternately, the power stage (L298N) may be inhibited to put the output in the state and achieve a faster current decay.

Since separate V_{ref} inputs are provided for each channel, each of the loads may be programmed independently allowing the device to be used to implement microstepping or applications with different peak and hold currents. In this type of application, changing the reference voltage (V_{ref}) will change the load current, effectively implementing a transconductance amplifier.

Figure 4 : Ripple Current in Bipolar Motors.

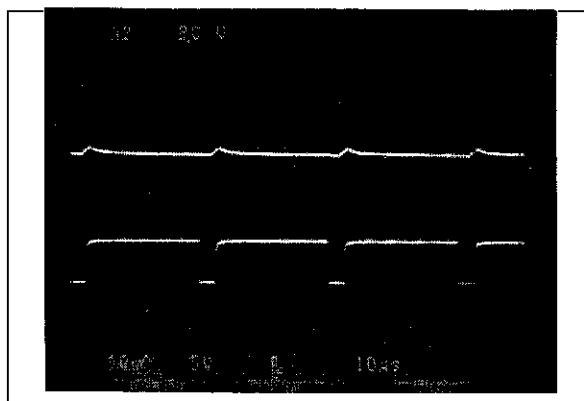

SYNCHRONIZING MULTIPLE DEVICES

Ground noise problems in multiple configurations can be avoided by synchronizing the oscillators. This may be done by connecting the sync pins of each of the devices with the oscillator output of the master device and connecting the R/C pin of the unused oscillators to ground as shown in figure 5. The devices may be synchronized to external circuits by applying synchronizing pulses to the sync pins. It should be noted, however, that the input pulse sets the minimum on time of the outputs and will therefore set a minimum output average current.

SELECTING THE OSCILLATOR COMPONENTS

When selecting the values for the external components for the oscillator one of the primary considerations is the operating frequency. In addition there is another important consideration for these components.

Figure 5 : Synchronizing Multiple Devices.

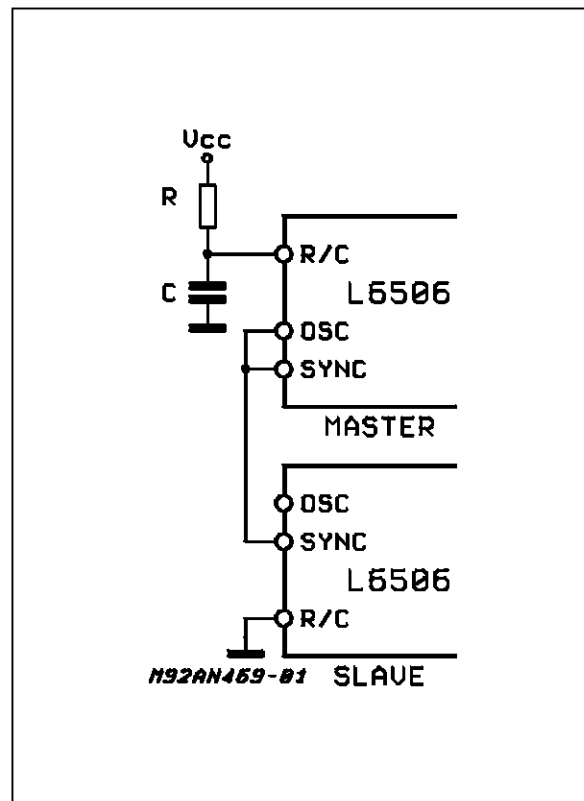

In many applications the reverse recovery current of the free wheeling diodes and of parasitic elements in the power stage will flow through the sensing resistor in addition to the load current. Also there is sometimes noise generated in the system when the power stage is switched on. These two

APPLICATION NOTE

sources of error can fool the current limiting stage and make it appear to operate at a subharmonic of the desired frequency. With the proper selection of the oscillator components this behavior can be avoided.

The design of the L6506 is such that the flip-flops used in the device are set dominant so that whenever the sync input is low the Q output of the flip-flop will be high even if the reset is applied by the comparator at the same time. This characteristic of the flip-flops can be used to make the current sensing immune to the recovery currents and noise spikes that occur when the power devices switch. If the sync pulse is longer than the turn on delay time of the power stage, as shown in figure 6, these two sources of errors will be ignored.

Figure 6 : Load Current and Sync Pulse.

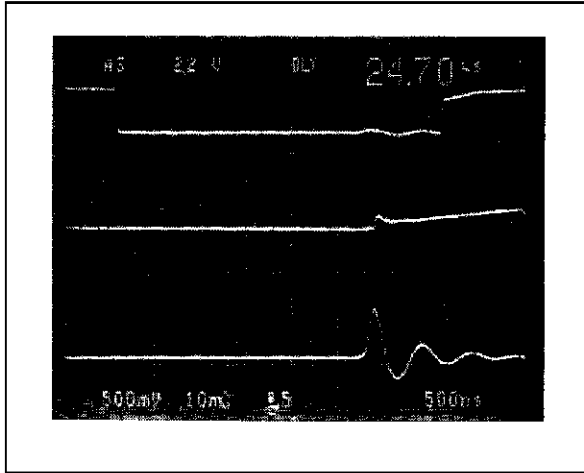

To select the proper values for the oscillator components a more detailed equation for the operating frequency and duty cycle of the oscillator is required. The required equations can be derived from the equivalent circuit for the oscillator section shown in figure 7.

As can be seen from figure 7, the full equation for the operating frequency includes not only the external resistance and capacitance but the internal discharge resistor as well. The full equation for the operating frequency is :

$$f = \frac{1}{0.69C1 \left[R1 + \left(\frac{R1 \cdot Ri}{R1 + Ri} \right) \right]} \quad (3)$$

The equations for the active time of the sync pulse ($T2$), the inactive time of the sync signal ($T1$) and the duty cycle can also be found by looking at the figure 7 and are :

$$T2 = 0.69C1 \frac{R1 Ri}{R1 + Ri} \quad (4)$$

$$T1 = 0.69 R1 C1 \quad (5)$$

$$DC = \frac{T2}{T1 + T2} \quad (6)$$

By substituting equations 4 and 5 into equation 6 and solving for the value of $R1$ the following equations for the external components can be derived:

$$R1 = \left(\frac{1}{DC} - 2 \right) Ri \quad (7)$$

$$C1 = \frac{T1}{0.69 R1} \quad (8)$$

Looking at equation 4 it can easily be seen that the minimum pulse width of $T2$ will occur when the value of Ri is at its minimum and the value of $R1$ at its maximum. Therefore, when evaluating equation 7 the minimum value for Ri of 700Ω ($1\text{K}\Omega -30\%$) should be used to guarantee the required pulse width.

For a typical application using the L298, which has a maximum turn on delay of $2.5\mu\text{s}$, with the L6506 consider the following operating points:

$$f = 20\text{KHz}$$

$$T1 + T2 = 50\mu\text{s}$$

$$T2 \text{ min} = 3\mu\text{s}$$

From equation 6:

$$DC = \frac{3\mu\text{s}}{50\mu\text{s}} = 0.06$$

From equation 7:

$$R1 = \left(\frac{1}{0.06} - 2 \right) 700 = 10.3\text{K}\Omega$$

From equation 8:

$$C1 = \frac{47\mu\text{s}}{(0.69) (10.3\text{K})} = 6.6\text{nF}$$

Figure 7 : Oscillator Circuit and Waveforms.

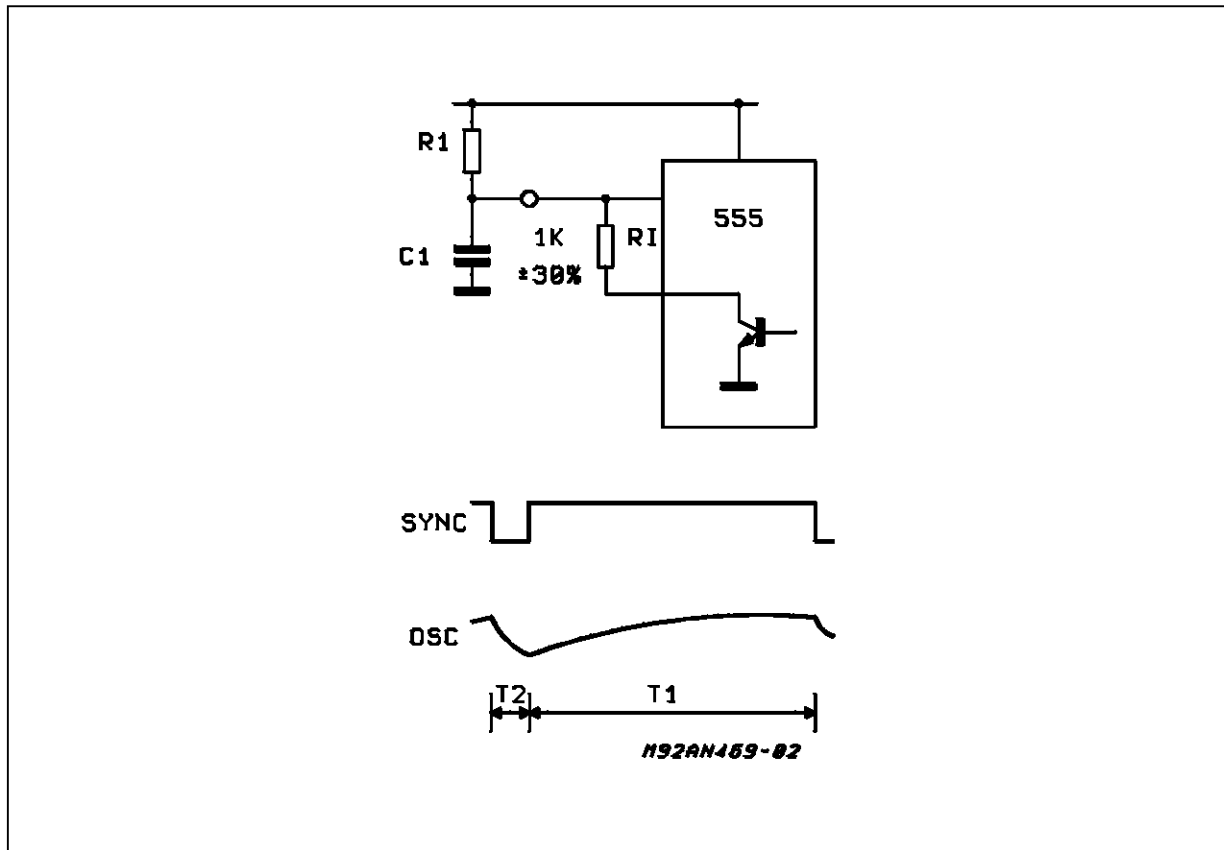

APPLICATION NOTE

Information furnished is believed to be accurate and reliable. However, SGS-THOMSON Microelectronics assumes no responsibility for the consequences of use of such information nor for any infringement of patents or other rights of third parties which may result from its use. No license is granted by implication or otherwise under any patent or patent rights of SGS-THOMSON Microelectronics. Specifications mentioned in this publication are subject to change without notice. This publication supersedes and replaces all information previously supplied. SGS-THOMSON Microelectronics products are not authorized for use as critical components in life support devices or systems without express written approval of SGS-THOMSON Microelectronics.

© 1995 SGS-THOMSON Microelectronics - All Rights Reserved

SGS-THOMSON Microelectronics GROUP OF COMPANIES

Australia - Brazil - France - Germany - Hong Kong - Italy - Japan - Korea - Malaysia - Malta - Morocco - The Netherlands - Singapore - Spain - Sweden - Switzerland - Taiwan - Thailand - United Kingdom - U.S.A.