

Hex Machine Screw Nuts, Zinc Plated

The information below lists the required dimensional, chemical and physical characteristics of the products in this purchase order. If the order received does not meet these requirements, it may result in a supplier corrective action request, which could jeopardize your status as an approved vendor. Unless otherwise specified, all referenced consensus standards must be adhered to in their entirety.

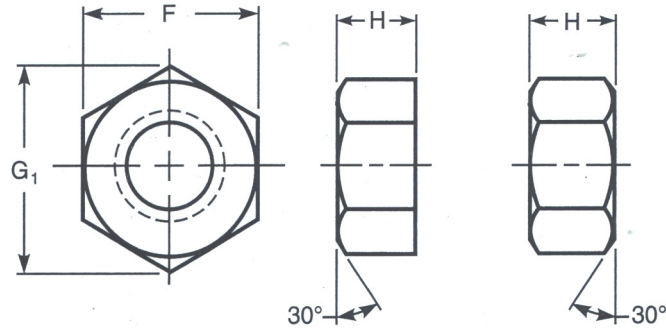

Size	F		G1		H	
	Width Across Flats		Width Across Corners		Thickness	
	Max.	Min.	Max.	Min.	Max.	Min.
0	.156	.150	.180	.171	.050	.043
1	.156	.150	.180	.171	.050	.043
2	.188	.180	.217	.205	.066	.057
3	.188	.180	.217	.205	.066	.057
4	.250	.241	.289	.275	.098	.087
5	.312	.302	.361	.344	.114	.102
6	.312	.302	.361	.344	.114	.102
8	.344	.332	.397	.378	.130	.117
10	.375	.362	.433	.413	.130	.117
12	.438	.423	.505	.482	.161	.148
1/4	.438	.423	.505	.482	.193	.178
5/16	.562	.545	.650	.621	.225	.208
3/8	.625	.607	.722	.692	.257	.239

Specification Requirements:

- Dimensions: ANSI/ASME B18.2.2
- Material: Carbon Steel.
- Threads: ASME B1.1 UNC & UNF Class 2B.
- Finish: Fe/Zn 3AT Per ASTM F1941