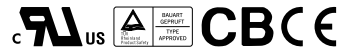
**■ Features :**

- Universal AC input/Full range
- 12V or 24V high peak output current capability
- **Optional L-Bracket and cover**
- Low leakage current<1mA
- Protections: Short circuit / Overload / Over voltage
- 60W free air convection, 77W with 18CFM forced air
- 100% full load burn-in test
- Fixed switching frequency at 65KHz
- 2 years warranty

**SPECIFICATION**

MODEL	RPD-65C		RPD-65D		
OUTPUT	OUTPUT NUMBER	CH1	CH2	CH1	CH2
	DC VOLTAGE	12V	5V	24V	5V
	RATED CURRENT	4.5A	1.2A	2.25A	1.2A
	CURRENT RANGE	0 ~ 5.8A	0 ~ 1.5A	0 ~ 2.9A	0 ~ 1.5A
	PEAK LOAD <small>Note.4</small>	7.5A	Rated load	3.75A	Rated load
	RATED POWER	60W			
	OUTPUT POWER (max.)	Rated output power for convection; 77W with 18CFM min. forced air			
	RIPPLE & NOISE (max.) <small>Note.2</small>	120mVp-p	50mVp-p	150mVp-p	50mVp-p
	VOLTAGE ADJ. RANGE	CH1:11.4 ~ 12.8V		CH1:22.8 ~ 26.4V	
	VOLTAGE TOLERANCE <small>Note.3</small>	±2.0%	±5.0%	±2.0%	±5.0%
	LINE REGULATION	±1.0%	±1.0%	±1.0%	±1.0%
	LOAD REGULATION	±2.0%	±5.0%	±2.0%	±5.0%
	SETUP, RISE TIME	800ms, 20ms at full load			
HOLD UP TIME (Typ.)	20ms at full load				
INPUT	VOLTAGE RANGE	90 ~ 264VAC 127 ~370VDC			
	FREQUENCY RANGE	47 ~ 440Hz			
	EFFICIENCY (Typ.)	79%		81%	
	AC CURRENT (Typ.)	1.5A/115VAC 0.9A/230VAC			
	INRUSH CURRENT (Typ.)	COLD START 25A/115VAC 50A/230VAC			
	LEAKAGE CURRENT	<1mA			
PROTECTION	OVERLOAD	90 ~ 125W output power Protection type : Hiccup mode, recovers automatically after fault condition is removed.			
	OVER VOLTAGE	CH1:13.8 ~ 16.2V		CH1:27.6 ~ 32.4V Protection type : Hiccup mode, recovers automatically after fault condition is removed.	
ENVIRONMENT	WORKING TEMP.	-20 ~ +60°C (Refer to output load derating curve)			
	WORKING HUMIDITY	20 ~ 90% RH non-condensing			
	STORAGE TEMP., HUMIDITY	-40 ~ +85°C, 10 ~ 95% RH			
	TEMP. COEFFICIENT	±0.04%/°C (0 ~ 50°C) on CH1 output			
	VIBRATION	10 ~ 500Hz, 2G 10min./1cycle, period for 60min. each along X, Y, Z axes			
SAFETY & EMC <small>(Note 4)</small>	SAFETY STANDARDS	UL60950-1, TUV EN60950-1 approved			
	WITHSTAND VOLTAGE	I/P-O/P:3KVAC I/P-FG:1.5KVAC O/P-FG:0.5KVAC			
	ISOLATION RESISTANCE	I/P-O/P, I/P-FG, O/P-FG:100M Ohms/500VDC			
	EMI CONDUCTION & RADIATION	Compliance to EN55022 (CISPR22) Class B			
	HARMONIC CURRENT	Compliance to EN61000-3-2,-3			
	EMS IMMUNITY	Compliance to EN61000-4-2,3,4,5,6,8,11; ENV50204, EN55024, light industry level, criteria A			
OTHERS	MTBF	288.1K hrs min. MIL-HDBK-217F (25°C)			
	DIMENSION	PCB:127*76*28mm (L*W*H) with optional CASE:130*84.4*37mm (L*W*H)			
	PACKING	0.24Kg; 63pcs/16Kg/1.35CUFT			
NOTE	<p>1. All parameters NOT specially mentioned are measured at 230VAC input, rated load and 25°C of ambient temperature.</p> <p>2. Ripple & noise are measured at 20MHz of bandwidth by using a 12" twisted pair-wire terminated with a 0.1uf & 47uf parallel capacitor.</p> <p>3. Tolerance : includes set up tolerance, line regulation and load regulation.</p> <p>4. 10% duty cycle maximum within every second. Average output power should not exceed the rated power, output voltage above 90% DC voltage.</p> <p>5. The power supply is considered a component which will be installed into a final equipment. The final equipment must be re-confirmed that it still meets EMC directives.</p>				

Mechanical Specification

Case No. 946A Unit:mm

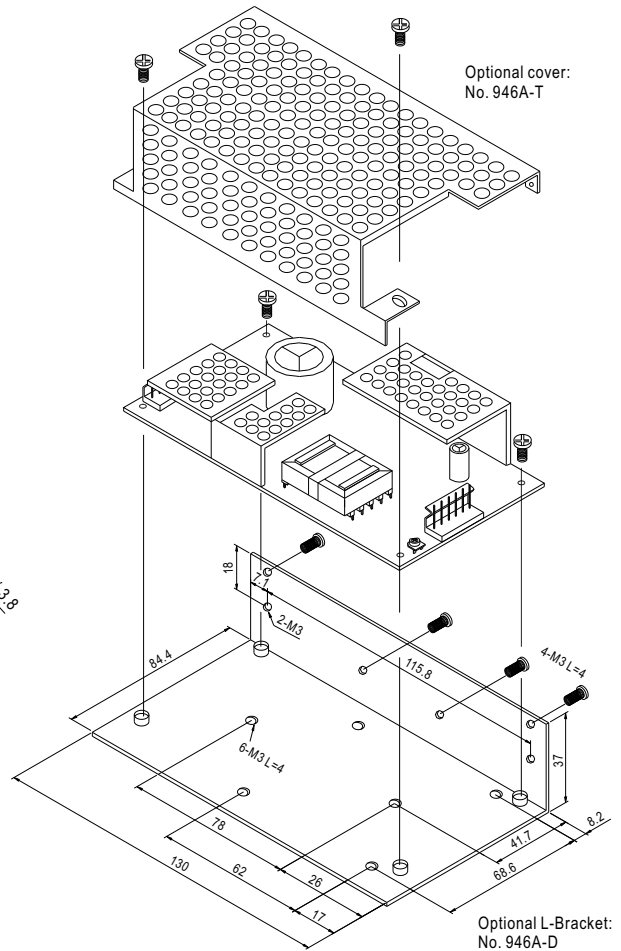
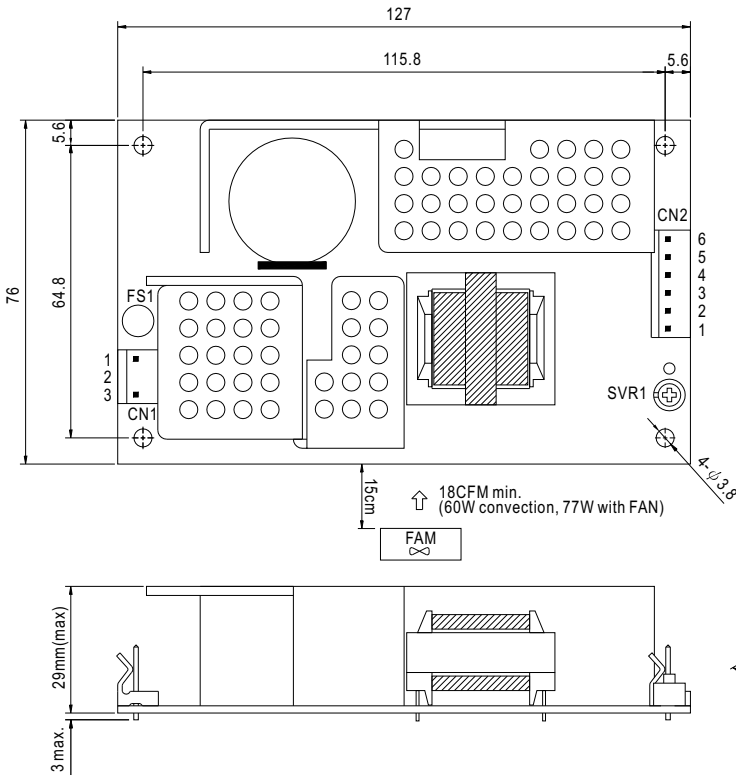

AC Input Connector (CN1) : Molex 5273-03 or equivalent

Pin No.	Assignment	Mating Housing	Terminal
1	AC/L	Molex 5195 or equivalent	Molex 5194 or equivalent
2	No Pin		
3	AC/N		

DC Output Connector (CN2) : Molex 5273-06 or equivalent

Pin No.	Assignment	Mating Housing	Terminal
1,2	V1	Molex 5195 or equivalent	Molex 5194 or equivalent
3,4	GND		
5	V2		
6	NC		

Block Diagram

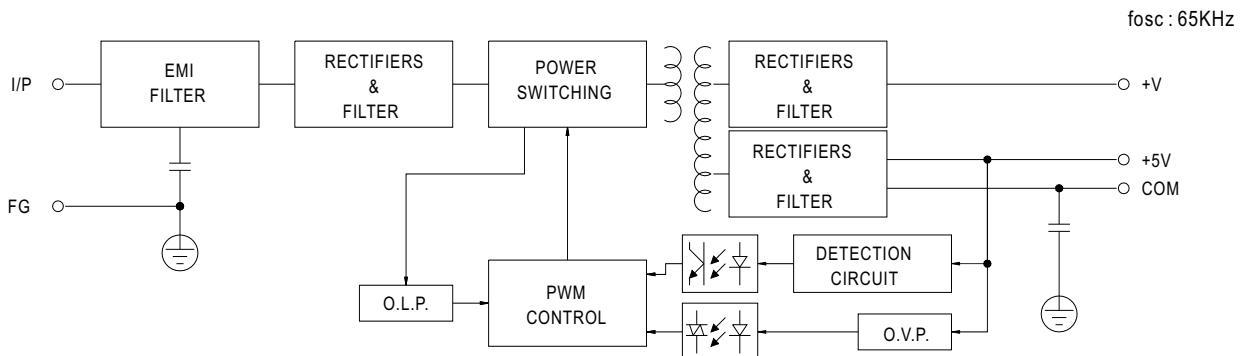



Derating Curve

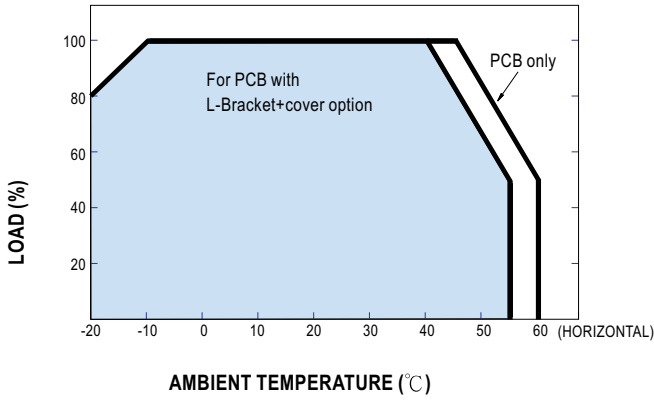

Output Derating VS Input Voltage

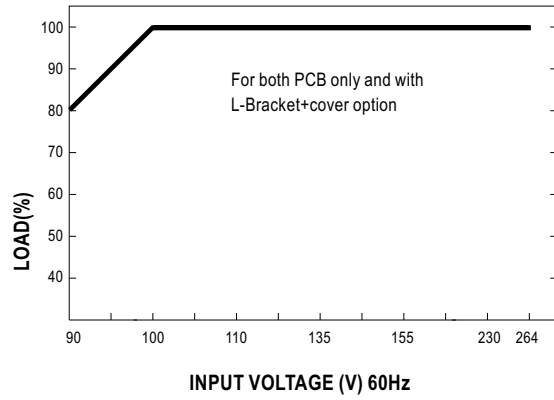

MODEL : RPD-65D

OUTPUT FUNCTION TEST

NO	TEST ITEM	SPECICATION	TEST CONDITION	RESULT	VERDICT
1	RIPPLE & NOISE	V1:150 mVp-p (Max) V2:50 mVp-p (Max)	I/P: 230VAC O/P:FULL LOAD Ta:25°C	V1: 12 mVp-p (Max) V2: 10 mVp-p (Max)	P
2	OUTPUT VOLTAGE ADJUST RANGE	CH1: 22.8V - 26.4V	I/P: 230 VAC I/P: 115 VAC O/P:MIN LOAD Ta:25°C	21.82 V- 27.43 V/ 230 VAC 21.82 V- 27.43 V/ 115 VAC	P
3	OUTPUT VOLTAGE TOLERANCE	V1: 2 % - -2 % (Max) V2: 5 % - -5 % (Max)	I/P: VAC / 264 VAC O/P:FULL/ MIN LOAD Ta:25°C	V1: 0.6 %- -0.6 % V2: 1.7 %- -1.7 %	P
4	LINE REGULATION	V1: 1 % - -1 % (Max) V2: 1 % - -1 % (Max)	I/P: VAC ~ 264 VAC O/P:FULL LOAD Ta:25°C	V1: 0.6 %- -0.08 % V2: 0 %- 0 %	P
5	LOAD REGULATION	V1: 2 % - -2 % (Max) V2: 5 % - -5 % (Max)	I/P: 230 VAC O/P:FULL ~MIN LOAD Ta:25°C	V1: 0.7 %- -0.7 % V2: 0.6 %- -0.6 %	P
6	CROSS REGULATION	V1: 2 % - -2 % (Max) V2: 5 % - -5 % (Max)	I/P: 230 VAC O/P: Testing O/P 60%LOAD Other O/P 40%LOAD Change Ta:25°C	V1: 0.5 %- -1.1 % V2: 0.2 %- -0.2 %	P
7	SET UP TIME	230VAC: 800 ms (Max)	I/P: 230 VAC O/P:FULL LOAD Ta:25°C	230VAC/ 196 ms	P
8	RISE TIME	230VAC: 20 ms (Max)	I/P: 230 VAC O/P:FULL LOAD Ta:25°C	230VAC/ 11 ms	P
9	HOLD UP TIME	230VAC: 20 ms (TYP)	I/P: 230 VAC O/P:FULL LOAD Ta:25°C	230VAC/ 108 ms	P
10	OVER/UNDERSHOOT TEST	< ±5%	I/P: 230 VAC O/P:FULL LOAD Ta:25°C	TEST: <5 %	P
11	DYNAMIC LOAD	V1: 2400 mVp-p	I/P: 230 VAC O/P:FULL /Min LOAD 90%DUTY/1KHZ Ta:25°C	151 mVp-p	P

INPUT FUNCTION TEST

NO	TEST ITEM	SPECICATION	TEST CONDITION	RESULT	VERDICT
1	INPUT VOLTAGE RANGE	90VAC~264 VAC	I/P:TESTING O/P:FULL LOAD Ta:25°C	48V~264V	P
			I/P: LOW-LINE-3V= 87V HIGH-LINE+15%=300 V O/P:FULL/MIN LOAD ON: 30 Sec . OFF: 30 Sec 10MIN (AC POWER ON/OFF NO DAMAGE)	TEST:OK	
2	INPUT FREQUENCY RANGE	47HZ ~440 HZ NO DAMAGE OSC	I/P: 90VAC ~ 264 VAC O/P:FULL~MIN LOAD Ta:25°C	TEST:OK	P
3	EFFICIENCY	81% (TYP)	I/P: 230 VAC O/P:FULL LOAD Ta:25°C	82.4 %	P
4	INPUT CURRENT	230V/ 0.9 A (TYP) 115V/ 1.5 A (TYP)	I/P: 230 VAC I/P: 115 VAC O/P:FULL LOAD Ta:25°C	I = 0.7 A/ 230 VAC I = 1.2 A/ 115 VAC	P
5	INRUSH CURRENT	230V/ 50 A (TYP) 115V/ 25 A (TYP) COLD START	I/P: 230 VAC I/P: 115 VAC O/P:FULL LOAD Ta:25°C	I = 36 A/ 230 VAC I = 18 A/ 115 VAC	P
6	LEAKAGE CURRENT	< 1 mA / 240 VAC	I/P: 254 VAC O/P:Min LOAD Ta:25°C	L-FG: 0.5 mA N-FG: 0.5 mA	P

PROTECTION FUNCTION TEST

NO	TEST ITEM	SPECICATION	TEST CONDITION	RESULT	VERDICT
1	OVER LOAD PROTECTION	90W~125W	I/P: 230 VAC I/P: 115 VAC O/P:TESTING Ta:25°C	114 W/ 230 VAC 112 W/ 115 VAC Hiccup Mode	P
2	OVER VOLTAGE PROTECTION	CH1:27.6V~ 32.4V	I/P: 230 VAC I/P: 115 VAC O/P:MIN LOAD Ta:25°C	30.3 V/ 230 VAC 30.3 V/ 115 VAC Hiccup Model	P
3	SHORT PROTECTION	SHORT EVERY OUTPUT 1 HOUR NO DAMAGE	I/P: 264 VAC O/P:FULL LOAD Ta:25°C	NO DAMAGE Hiccup Mode	P

ENVIRONMENT TEST

NO	TEST ITEM	SPECIFICATION	TEST CONDITION	RESULT	VERDICT																																																																																
1	TEMPERATURE RISE TEST	MODEL : RPD-65D 1. ROOM AMBIENT BURN-IN : 2HRS I/P: 230VAC O/P: FULL LOAD Ta= 26.7°C 2. HIGH AMBIENT BURN-IN : 2HRS I/P: 230VAC O/P: FULL LOAD Ta= 51.7°C																																																																																			
				<table border="1"> <thead> <tr> <th>NO</th> <th>Position</th> <th>P/N</th> <th>ROOM AMBIENT Ta= 26.7°C</th> <th>HIGH AMBIENT Ta=51.7°C</th> </tr> </thead> <tbody> <tr><td>1</td><td>LF1</td><td>TF-484</td><td>52.4°C</td><td>72.8°C</td></tr> <tr><td>2</td><td>BD1</td><td>D3SB60 4A/600V SHI</td><td>60.1°C</td><td>77.8°C</td></tr> <tr><td>3</td><td>C5</td><td>150U/400V RUB 85°C USP</td><td>58.2°C</td><td>76.8°C</td></tr> <tr><td>4</td><td>R5</td><td>47K/2W R/MO</td><td>78.7°C</td><td>93.8°C</td></tr> <tr><td>5</td><td>Q1</td><td>2SK3562 6A/600V</td><td>67.4°C</td><td>86.5°C</td></tr> <tr><td>6</td><td>C10</td><td>100U/35V RUB 105°C YXF</td><td>54.6°C</td><td>75.0°C</td></tr> <tr><td>7</td><td>D1</td><td>HER306 3A/600V</td><td>72.5°C</td><td>91.1°C</td></tr> <tr><td>8</td><td>D100</td><td>D9202 20A/200V</td><td>74.3°C</td><td>91.8°C</td></tr> <tr><td>9</td><td>C106</td><td>470U/35V RUB 105°C YXG</td><td>68.8°C</td><td>86.4°C</td></tr> <tr><td>10</td><td>T1 COIL</td><td>TF-1342</td><td>68.8°C</td><td>84.5°C</td></tr> <tr><td>11</td><td>C206</td><td>1000U/25V RUB 105°C YXG</td><td>59.2°C</td><td>78.2°C</td></tr> <tr><td>12</td><td>U1</td><td>1203</td><td>57.4°C</td><td>77.2°C</td></tr> <tr><td>13</td><td>D200</td><td>SF10SC60 10A/60V</td><td>69.5°C</td><td>87.8°C</td></tr> <tr><td>14</td><td>RG200</td><td>78R05 3A/5V</td><td>69.4°C</td><td>87.8°C</td></tr> <tr><td>15</td><td></td><td></td><td>°C</td><td>°C</td></tr> </tbody> </table>	NO	Position	P/N	ROOM AMBIENT Ta= 26.7°C	HIGH AMBIENT Ta=51.7°C	1	LF1	TF-484	52.4°C	72.8°C	2	BD1	D3SB60 4A/600V SHI	60.1°C	77.8°C	3	C5	150U/400V RUB 85°C USP	58.2°C	76.8°C	4	R5	47K/2W R/MO	78.7°C	93.8°C	5	Q1	2SK3562 6A/600V	67.4°C	86.5°C	6	C10	100U/35V RUB 105°C YXF	54.6°C	75.0°C	7	D1	HER306 3A/600V	72.5°C	91.1°C	8	D100	D9202 20A/200V	74.3°C	91.8°C	9	C106	470U/35V RUB 105°C YXG	68.8°C	86.4°C	10	T1 COIL	TF-1342	68.8°C	84.5°C	11	C206	1000U/25V RUB 105°C YXG	59.2°C	78.2°C	12	U1	1203	57.4°C	77.2°C	13	D200	SF10SC60 10A/60V	69.5°C	87.8°C	14	RG200	78R05 3A/5V	69.4°C	87.8°C	15			°C	°C	P
NO	Position	P/N	ROOM AMBIENT Ta= 26.7°C	HIGH AMBIENT Ta=51.7°C																																																																																	
1	LF1	TF-484	52.4°C	72.8°C																																																																																	
2	BD1	D3SB60 4A/600V SHI	60.1°C	77.8°C																																																																																	
3	C5	150U/400V RUB 85°C USP	58.2°C	76.8°C																																																																																	
4	R5	47K/2W R/MO	78.7°C	93.8°C																																																																																	
5	Q1	2SK3562 6A/600V	67.4°C	86.5°C																																																																																	
6	C10	100U/35V RUB 105°C YXF	54.6°C	75.0°C																																																																																	
7	D1	HER306 3A/600V	72.5°C	91.1°C																																																																																	
8	D100	D9202 20A/200V	74.3°C	91.8°C																																																																																	
9	C106	470U/35V RUB 105°C YXG	68.8°C	86.4°C																																																																																	
10	T1 COIL	TF-1342	68.8°C	84.5°C																																																																																	
11	C206	1000U/25V RUB 105°C YXG	59.2°C	78.2°C																																																																																	
12	U1	1203	57.4°C	77.2°C																																																																																	
13	D200	SF10SC60 10A/60V	69.5°C	87.8°C																																																																																	
14	RG200	78R05 3A/5V	69.4°C	87.8°C																																																																																	
15			°C	°C																																																																																	
2	OVER LOAD BURN-IN TEST	NO DAMAGE 1 HOUR (MIN)	I/P: 230 VAC O/P: 109W Ta:25°C	TEST : OK	P																																																																																
3	LOW TEMPERATURE TURN ON TEST	TURN ON AFTER 1.5 HOUR	I/P: 230 VAC O/P: 100% LOAD Ta= -10°C	TEST : OK	P																																																																																
4	HIGH HUMIDITY HIGH TEMPERATURE HIGH VOLTAGE TURN ON TEST	AFTER 12 HOURS IN CHAMBER ON CONTROL 50°C NO DAMAGE	I/P: 272 VAC O/P:FULL LOAD Ta= 50°C HUMIDITY= 95 %R.H	TEST : OK	P																																																																																
5	TEMPERATURE COEFFICIENT	± 0.04 %(0-50°C)	I/P: 230 VAC O/P:FULL LOAD	± 0.01%(0-50°C)	P																																																																																
6	VIBRATION TEST	1 Set (1) Waveform: Sine Wave (2) Frequency:10-500Hz (3) Sweep Time:10min/sweep cycle (4) Acceleration:2G (5) Test Time:1 hour in each axis (X.Y.Z) (6) Ta:25°C		TEST : OK	P																																																																																

SAFETY TEST

NO	TEST ITEM	SPECIFICATION	TEST CONDITION	RESULT	VERDICT
1	WITHSTAND VOLTAGE	I/P-O/P: 3 KVAC/min I/P-FG: 1.5 KVAC/min O/P-FG: 0.5 KVAC/min	I/P-O/P: 3.6 KVAC/min I/P-FG: 1.8 KVAC/min O/P-FG: 0.6 KVAC/min Ta:25°C	I/P-O/P: 4.92 mA I/P-FG: 4.21 mA O/P-FG: 3.39 mA NO DAMAGE	P
2	ISOLATION RESISTANCE	I/P-O/P:500VDC>100MΩ I/P-FG: 500VDC>100MΩ O/P-FG:500VDC>100MΩ	I/P-O/P: 500 VDC I/P-FG: 500 VDC O/P-FG: 500 VDC Ta:25°C	I/P-O/P: 5 GΩ I/P-FG: 2 GΩ O/P-FG: 2 GΩ NO DAMAGE	P
3	GROUNDING CONTINUITY	FG(PE) TO CHASSIS OR TRACE < 100 mΩ	40 A / 2min Ta:25°C	5 mΩ	P
4	APPROVAL	TUV: Certificate NO : R50072114 UL: File NO : E183223			P

E.M.C TEST

NO	TEST ITEM	SPECIFICATION	TEST CONDITION	RESULT	VERDICT
1	HARMONIC	EN61000-3-2 CLASS A	I/P: 230 VAC/50HZ O/P:FULL LOAD Ta:25°C	PASS	P
2	CONDUCTION	EN55022 CLASS B	I/P: 230 VAC (50HZ) O/P:FULL/50% LOAD Ta:25°C	PASS Test by certified Lab	P
3	RADIATION	EN55022 CLASS B	I/P: 230 VAC (50HZ) O/P:FULL LOAD Ta:25°C	PASS Test by certified Lab	P
4	E.S.D	EN61000-4-2 LIGHT INDUSTRY AIR:8KV / Contact:4KV	I/P: 230 VAC/50HZ O/P:FULL LOAD Ta:25°C	CRITERIA A	P
5	E.F.T	EN61000-4-4 LIGHT INDUSTRY INPUT: 1KV	I/P: 230 VAC/50HZ O/P:FULL LOAD Ta:25°C	CRITERIA A	P
6	SURGE	IEC61000-4-5 LIGHT INDUSTRY L-N :1KV L,N-PE:2KV	I/P: 230 VAC/50HZ O/P:FULL LOAD Ta:25°C	CRITERIA A	P
7	Test by certified Lab & Test Report Prepare				

M.T.B.F & LIFE CYCLE CALCULATION

NO	TEST ITEM	SPECIFICATION	TEST CONDITION	RESULT	VERDICT
1	CAPACITOR LIFE CYCLE	SUPPOSE C105 IS THE MOST CRITICAL COMPONENT I/P: 230VAC O/P:FULL LOAD Ta=25 °C LIFE TIME= 82703 HRS I/P: 230VAC O/P:FULL LOAD Ta=50 °C LIFE TIME= 24398 HRS			P
2	MTBF	MIL-HDBK-217F NOTICES2 PARTS COUNT TOTAL FAILURE RATE: 288.1KHRS			P

COMPONENT STRESS TEST

NO	TEST ITEM	SPECICATION	TEST CONDITION	RESULT	VERDICT
1	Power Transistor (D to S) or (C to E) Peak Voltage	Q1 Rated 2SK3562 : 600V 6A	I/P:High-Line +3V = 267 V O/P: (1)Full Load Turn on (2) Full Load (3)Output Short Ta:25°C	(1) 478 V (2) 480 V (3) 548 V	P
2	Diode Peak Voltage	D100 Rated D9202 : 200V 20 A D200 Rated SF10SC6 : 60V 10 A	I/P:High-Line +3V = 267 V O/P: (1)Full Load Turn on (2) Full Load (3)Output Short Ta:25°C	(1) 138 V (2) 150 V (3) 138 V (1) 41.6 V (2) 44.4 V (3) 42.8 V	P
3	Clamp Diode Peak Voltage	D1 Rated HER306 : 600V 3A	I/P:High-Line +3V = 267 V O/P: (1)Full Load (2) Dynamic Load 90%Duty/1KHz Ta:25°C	(1) 454 V (2) 454 V	P
4	Input Capacitor Voltage	C5 Rated : 150u/ 400V/ 85°C	I/P:High-Line +3V = 267 V O/P: (1)Full Load Turn on /Off (2) Min load Turn on /Off (3)Full Load /Min load Change (4)Burn in 1hour Ta:25°C	(1) 382 V (2) 382 V (3) 382 V (4) 376 V	P
5	Control IC Voltage Test	U1 Rated 1203 : 16V	I/P:High-Line +3V = 267 V O/P: (1)Full Load Turn on /Off (2) Min load Turn on /Off (3)Full Load /Min load Change Ta:25°C	(1) 13.1 V (2) 13.1 V (3) 10.8 V	P

DATE	SAMPLE	TEST RESULT	TESTER	APPROVAL
2005/5/31	RD SAMPLE	PASS	VINCENT TSENG	MAX LIN
2005/11/18	PRODUCT SAMPLE W0510A21	PASS	VINCENT TSENG	MAX LIN
2006/3/29	PRODUCT SAMPLE W0603B31	PASS	VINCENT TSENG	MAX LIN

2003/12/12 A50-F023