

Distributed by:

**JAMECO**<sup>®</sup>  
ELECTRONICS

**www.Jameco.com ♦ 1-800-831-4242**

The content and copyrights of the attached  
material are the property of its owner.

Jameco Part Number 739972

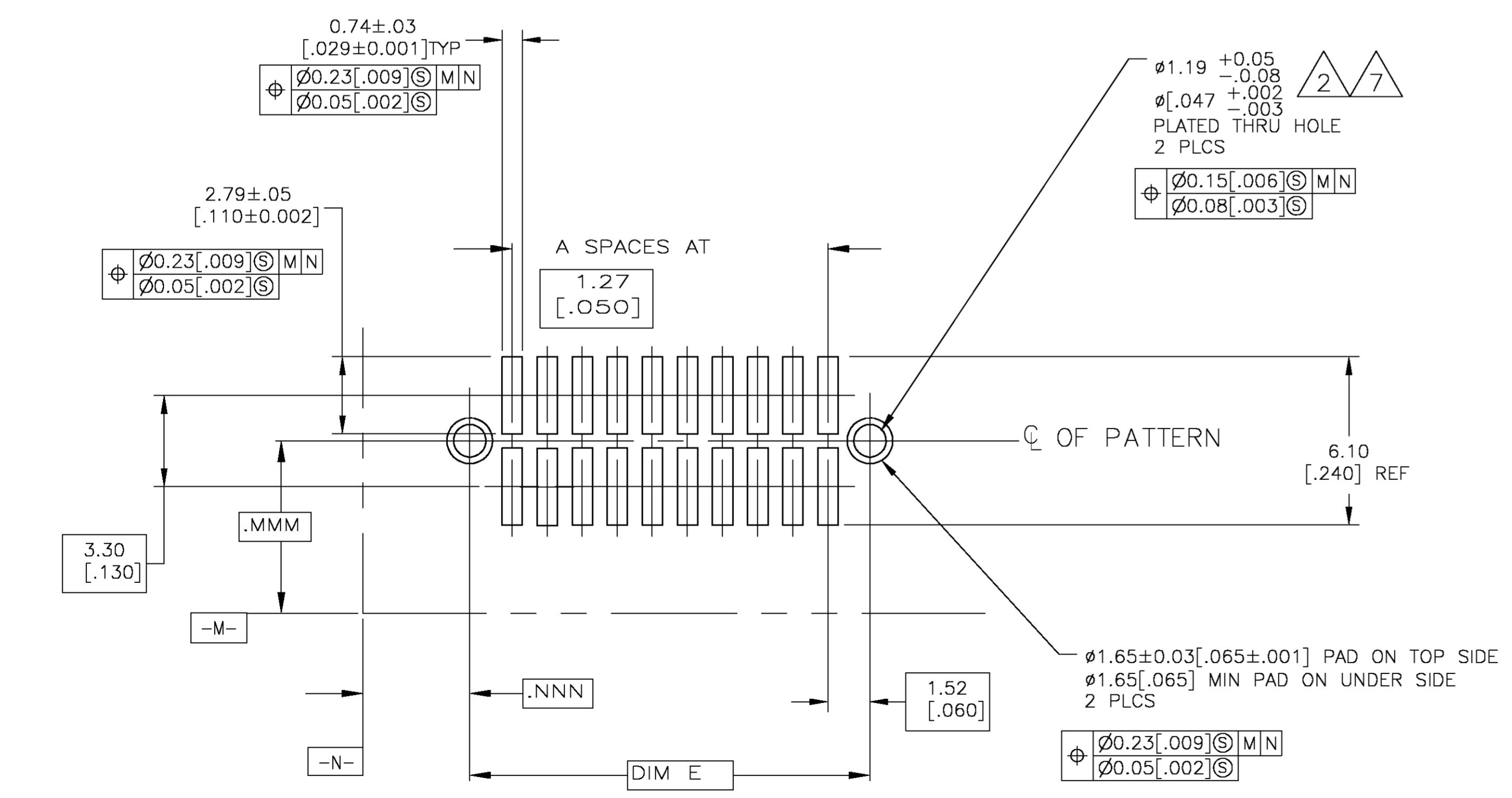
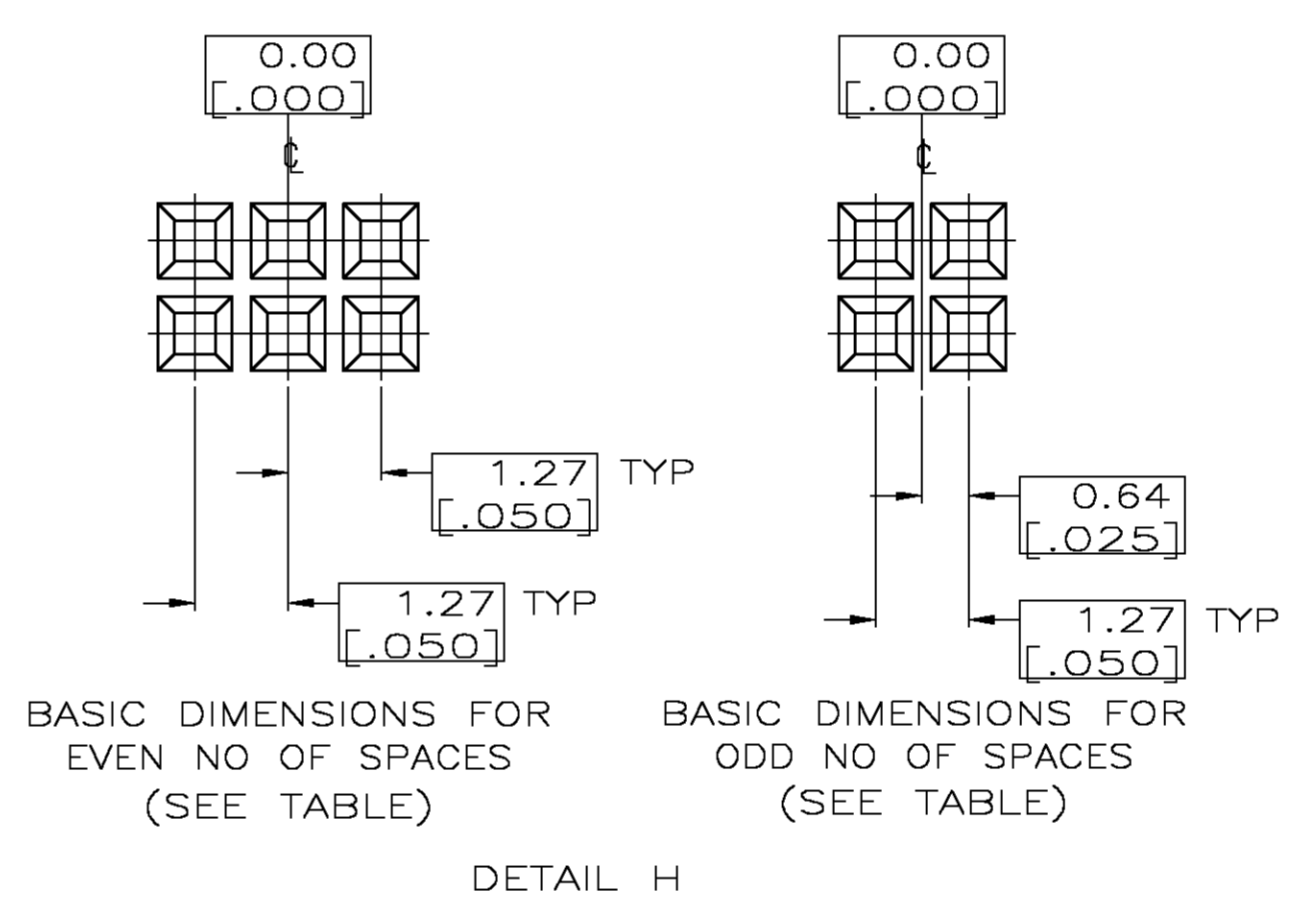
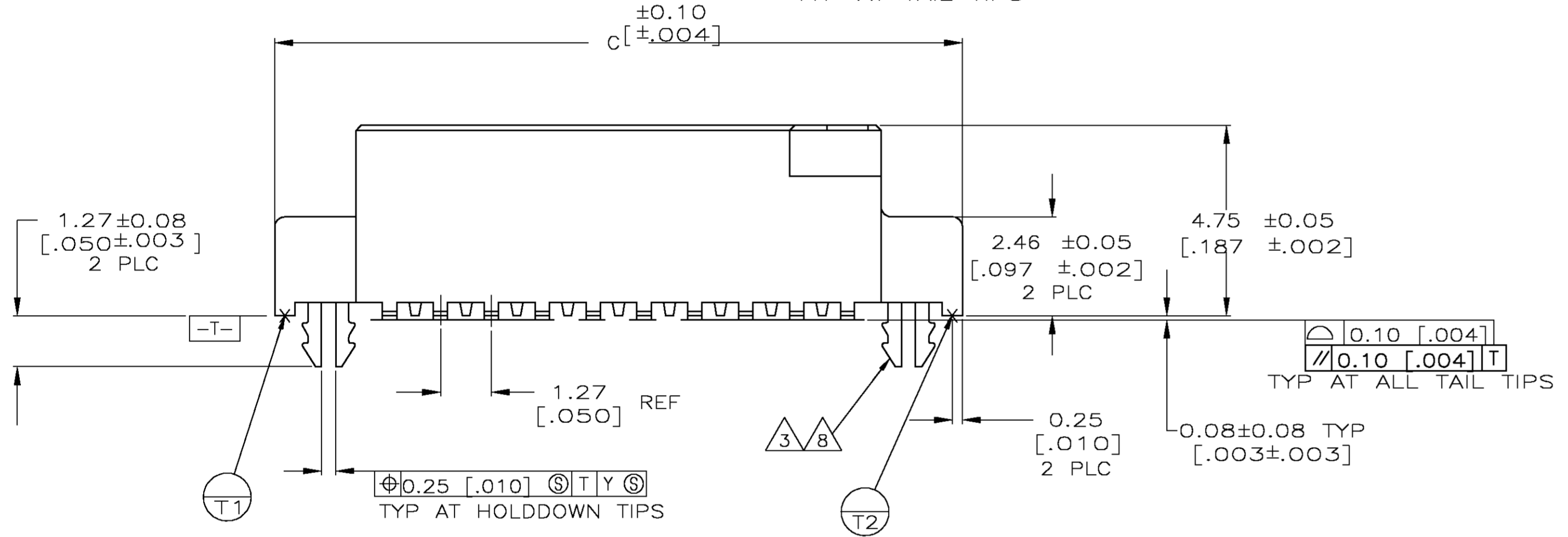
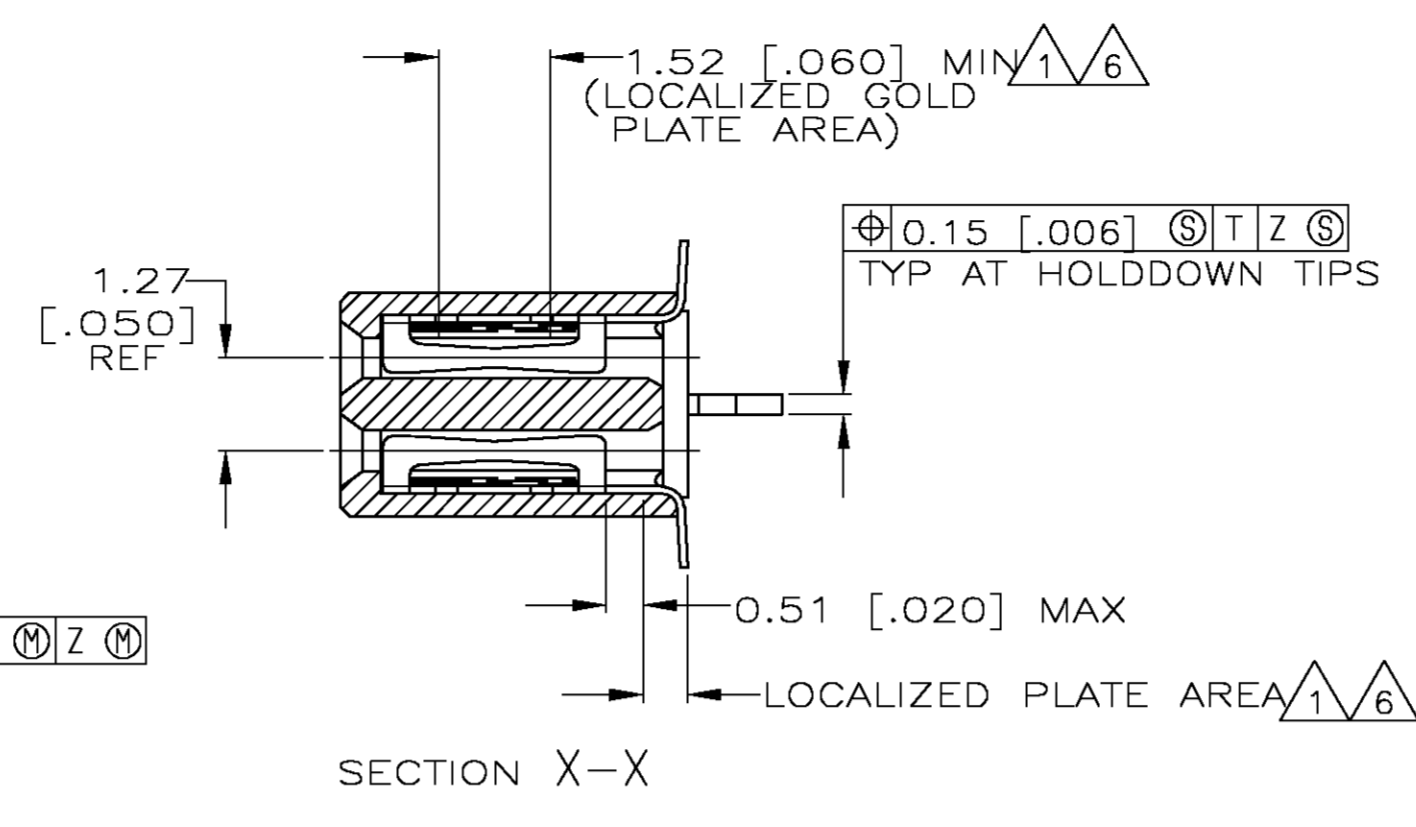
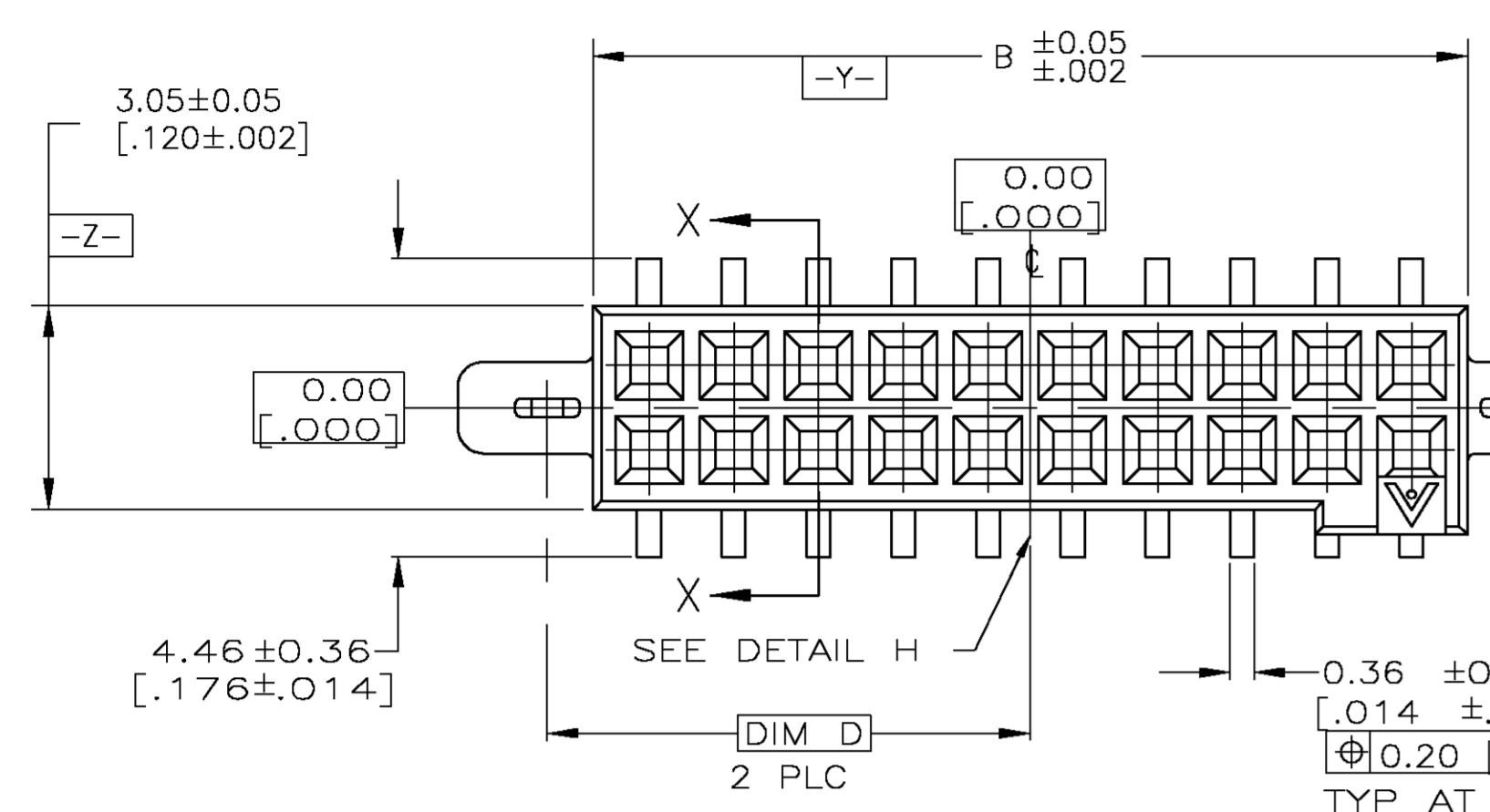

- 1 0.00076 [.000030] GOLD IN LOCALIZED PLATE AREA  
0.00381 [.000150] TIN-LEAD ON SOLDER TAILS  
ALL OVER 0.00127 [.000050] NICKEL
- 2 USE 1.32±0.02 [.0520±.0010] DRILLED HOLE (#55 DRILL)  
FINISH TO BE TIN/LEAD OVER 0.02 [.001] MIN COPPER
- 3 PLATING: 0.0038 [.000150] TIN-LEAD OVER 0.00127 [.000050] NICKEL
- 4. IF PLANNING TO USE MORE THAN ONE MATING PAIR OF CONNECTORS  
TO INTERCONNECT 2 BOARDS, PLEASE REFER TO "SPACING"  
PARAGRAPH IN THE APPLICATION SPEC, #114-7010
- 5 HOUSING: LCP, COLOR:BLACK.  
CONTACT: COPPER ALLOY PER ASTM SPECIFICATION B422.  
HOLDDOWN: COPPER ALLOY PER ASTM SPECIFICATION B194.
- 6 0.00076 [.000030] GOLD IN LOCALIZED PLATE AREA  
0.00381 [.000150] TIN ON SOLDER TAILS  
ALL OVER 0.00127 [.000050] NICKEL
- 7 USE 1.32±0.02 [.0520±.0010] DRILLED HOLE (#55 DRILL)  
FINISH TO BE TIN OVER 0.02 [.001] MIN COPPER
- 8 PLATING: 0.0038 [.000150] TIN OVER 0.00127 [.000050] NICKEL
- 9 PRELIMINARY PART - NOT RELEASED FOR PRODUCTION.

6/8	11.93	5.97	14.63	10.56	7	16	6-104652-1
6/8	65.28	32.640	67.97	63.91	49	100	6-104652-0
6/8	2.570	1.285	2.676	2.516	44	90	5-104652-9
6/8	58.93	29.46	61.62	57.56	44	90	5-104652-8
6/8	2.320	1.160	2.426	2.266	39	80	5-104652-8
6/8	52.58	26.290	55.27	51.21	34	70	5-104652-7
6/8	2.070	1.035	2.176	2.016	34	70	5-104652-7
6/8	46.23	23.11	48.92	44.86	29	60	5-104652-6
6/8	1.820	.910	1.926	1.766	29	60	5-104652-6
6/8	39.88	19.940	42.57	38.51	24	50	5-104652-5
6/8	1.570	.785	1.676	1.516	24	50	5-104652-5
6/8	33.53	16.76	36.22	32.16	19	40	5-104652-4
6/8	1.320	.660	1.426	1.266	19	40	5-104652-4
6/8	27.18	13.590	29.87	25.81	14	30	5-104652-3
6/8	1.070	.535	1.176	1.016	14	30	5-104652-3
6/8	20.83	10.41	23.52	19.46	9	20	5-104652-2
6/8	.820	.410	.926	.766	9	20	5-104652-2
6/8	14.48	7.240	17.17	13.11	4	10	5-104652-1
6/8	.570	.285	.676	.516	4	10	5-104652-1
6/8	8.12	4.06	10.82	6.75			
6/8	.320	.160	.426	.266			
OBSOLETE	11.93	5.97	14.63	10.56	7	16	1-104652-1
OBSOLETE	65.28	32.640	67.97	63.91	49	100	1-104652-0
OBSOLETE	2.570	1.285	2.676	2.516	44	90	104652-9
OBSOLETE	58.93	29.46	61.62	57.56	44	90	104652-8
OBSOLETE	2.320	1.160	2.426	2.266	39	80	104652-8
OBSOLETE	52.58	26.290	55.27	51.21	34	70	104652-7
OBSOLETE	2.070	1.035	2.176	2.016	34	70	104652-7
OBSOLETE	46.23	23.11	48.92	44.86	29	60	104652-6
OBSOLETE	1.820	.910	1.926	1.766	29	60	104652-6
OBSOLETE	39.88	19.940	42.57	38.51	24	50	104652-5
OBSOLETE	1.570	.785	1.676	1.516	24	50	104652-5
OBSOLETE	33.53	16.76	36.22	32.16	19	40	104652-4
OBSOLETE	1.320	.660	1.426	1.266	19	40	104652-4
OBSOLETE	27.18	13.590	29.87	25.81	14	30	104652-3
OBSOLETE	1.070	.535	1.176	1.016	14	30	104652-3
OBSOLETE	20.83	10.41	23.52	19.46	9	20	104652-2
OBSOLETE	.820	.410	.926	.766	9	20	104652-2
OBSOLETE	14.48	7.240	17.17	13.11	4	10	104652-1
OBSOLETE	.570	.285	.676	.516	4	10	104652-1
OBSOLETE	8.12	4.06	10.82	6.75			
OBSOLETE	.320	.160	.426	.266			
FINISH	E	D	C	B	A	NO OF POS	PART NUMBER

THIS DRAWING IS A CONTROLLED DOCUMENT. DWG: KATE HELM 08/07/91  
 CHK: D. GORENC 8/12/91  
 DIMENSIONS: mm [INCHES] TOLERANCES UNLESS OTHERWISE SPECIFIED:  
 0 PLC ± -  
 1 PLC ± -  
 2 PLC ± -  
 3 PLC ± -  
 4 PLC ± -  
 ANGLES ± -  
 MATERIAL: 5 FINISH: SEE TABLE  
 PRODUCT SPEC: 108-1332  
 APPLICATION SPEC: 114-7010  
 WEIGHT: -  
 CUSTOMER DRAWING: -  
 Tyco Electronics Corporation  
 Harrisburg, Pa 17105-3608  
 ASSEMBLY, RECEPTACLE, VERTICAL, DOUBLE ROW, SURFACE MOUNT, AMPMODU 50/50 GRID CONNECTOR  
 SIZE: A1 CAGE CODE: 00779 DRAWING NO: 104652  
 SCALE: 10:1 SHEET: 1 OF 1 REV: L

RECOMMENDED BOARD LAYOUT  
 SCALE: 7:1