

Distributed by:

JAMECO[®]
ELECTRONICS

www.Jameco.com ♦ 1-800-831-4242

The content and copyrights of the attached
material are the property of its owner.

Jameco Part Number 741677

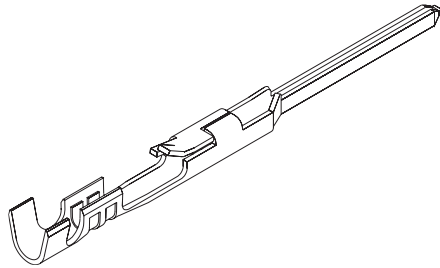
2.54mm (.100") Pitch**SL™
Terminal****70021
Male, Crimp****Features and Benefits**

- Dual tab strain relief
- Locking tang secures terminal in housing

Reference Information

Product Specification: PS-70021
 Packaging: Reel or bag
 Mates With: 70058 and 71851 female crimp terminals,
 and 70400 and 70430 connector assemblies
 Use With: 70066D and 70107 housings
 Designed In: Inches

Electrical

Voltage: 250V
 Current: 3.0A
 Contact Resistance: 15 milliohms max.
 Insulation Resistance: 10,000 Megohms min.

Mechanical

Wire Pull-Out Force: 17.79N (4.0 lb) min.
 Durability: Tin—25 cycles; Gold—50 cycles

Physical

Contact: Copper Alloy
 Plating: See Table
 Operating Temperature: -40 to +105°C
 Wire Gauge: 22 to 24 and 24 to 30 AWG

Not For Use With C-Grid III™ Components

Reel				
Order No.	Plating	Wire Range (AWG) Stranded	Insulation Maximum Outside Diameter	Lead-free
16-02-0116	1	22-24	1.63 (.064)	Yes
16-02-0078		24-30	1.52 (.060)	
16-02-0081	2	22-24	1.63 (.064)	
16-02-0077		24-30	1.52 (.060)	
16-02-0107	3	22-24	1.63 (.064)	
16-02-0105		24-30	1.52 (.060)	

Plating No. 1: 30µm min. Gold in select area over 50µm min. Nickel overall with 75µm Tin in select area
 Plating No. 2: 15µm min. Gold in select area over 50µm min. Nickel overall with 75µm min. Tin in select area
 Plating No. 3: 150µm Tin over 50µm Nickel overall
 Each reel contains 20,000 terminals

Bag				
Order No.	Plating	Wire Range (AWG) Stranded	Insulation Maximum Outside Diameter	Lead-free
16-02-0117	1	22-24	1.63 (.064)	Yes
16-02-0110		24-30	1.52 (.060)	
16-02-0115	2	22-24	1.63 (.064)	
16-02-0109		24-30	1.52 (.060)	
16-02-0114	3	22-24	1.63 (.064)	
16-02-0108		24-30	1.52 (.060)	

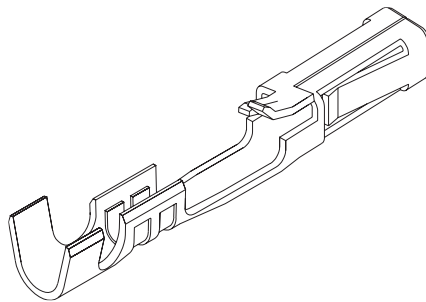
2.54mm (.100") Pitch**SL™
Terminal****70058
Female Box, Crimp****Features and Benefits**

- Dual beam, fully-enclosed box contact
- Dual tab strain relief
- Locking tang secures terminal in housing

Reference Information

Product Specification: PS-70058
 Packaging: Reel or bag
 Mates With: 70021 male crimp terminals and
 0.64mm (.025") square pins
 Use With: All 70066 and 70450 housings
 Designed In: Inches

Electrical

Voltage 250V
 Current: 3.0A
 Contact Resistance: 15 milliohms max.
 Insulation Resistance: 10,000 Megohms min.

Mechanical

Contact Retention to Housing: 17.79N (4.0 lb) min.
 Wire Pull-Out Force: 17.79N (4.0 lb) min.
 Mating Force: 2.22N (.50 lb) max.
 Unmating Force: 0.28N (.06 lb) min.
 Normal Force: 0.98N (.22 lb) min.
 Durability: Tin—25 cycles; Gold—50 cycles

Physical

Contact: Copper Alloy
 Plating: See Table
 Operating Temperature: -40 to +105°C
 Wire Gauge: 22 to 24 and 24 to 30 AWG

Not For Use With C-Grid III™ Components

Reel				
Order No.	Plating	Wire Range (AWG) Stranded	Insulation Maximum Outside Diameter	Lead-free
16-02-0088	1	22-24	1.63 (.064)	Yes
16-02-0083		24-30	1.52 (.060)	
16-02-0087	2	22-24	1.63 (.064)	
16-02-0082		24-30	1.52 (.060)	
16-02-0086	3	22-24	1.63 (.064)	
16-02-0069		24-30	1.52 (.060)	

Plating No. 1: 30µm min. Gold in select area over 50µm min. Nickel overall with 75µm Tin in select area
 Plating No. 2: 15µm min. Gold in select area over 50µm min. Nickel overall with 75µm min. Tin in select area
 Plating No. 3: 150µm Tin over 50µm Nickel overall
 Each reel contains 20,000 terminals

Bag				
Order No.	Plating	Wire Range (AWG) Stranded	Insulation Maximum Outside Diameter	Lead-free
16-02-0104	1	22-24	1.63 (.064)	Yes
16-02-0098		24-30	1.52 (.060)	
16-02-0103	2	22-24	1.63 (.064)	
16-02-0097		24-30	1.52 (.060)	
16-02-0102	3	22-24	1.63 (.064)	
16-02-0096		24-30	1.52 (.060)	



PRODUCT SPECIFICATION

“SL CRIMP TERMINAL”

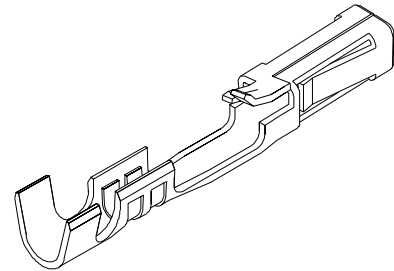

1.0 SCOPE

This specification covers the crimp terminal #70058-**** used with the single row fully stackable connector housing #70066-****, and the dual row fully stackable connector housing #70450-****.

2.0 PRODUCT DESCRIPTION

SERIES 70058 TERMINAL

2.1 Product is available in single row 2-25 circuits, on (2.54) .100” centers, or dual row 4-50 circuits on (2.54) .100 x (2.54) .100 centers.

2.2 Connector assemblies will mate with the following:

2.2.1 (0.64) .025” square or round pins assembled directly into P.C. board on .100 centers.

2.2.2 Shrouded or unshrouded single or dual-row wafers, with (0.64) .025 square or round pins.

2.2 Connectors are stackable end to end, side to side on (2.54) .100” center pins with option “A” housing only.

2.2.1 Polarizing ribs available on front of housing for use with headers, or on back for use with interim clip assemblies, housing #70066-**** only.

2.2.2 Active latch with polarizing ribs, for use with headers, housing #70066-**** only.

2.3 Maximum mating pin height to be (8.13) .320”, minimum pin height to be (5.08) .200”. Pin height, measured from top of wafers or P.C. board, to top of pin.

REVISION: F	ECR/ECN INFORMATION: EC No: UDT2002-1319 DATE: 2002 / 04 / 30	TITLE: PRODUCT SPECIFICATION FOR SL CRIMP TERMINAL SERIES 70058	SHEET No. 1 of 8
DOCUMENT NUMBER: PS-70058	CREATED / REVISED BY: ACHAMMER	CHECKED BY: BRINKMAN	APPROVED BY: BRINKMAN



PRODUCT SPECIFICATION

"SL CRIMP TERMINAL"

2.4 Connector assembly will accept wire range from 36 to 20 AWG. Refer to the table below for the wire gage, wire requirements, and crimp height.

WIRE GAGE (AWG)	CRIMP HEIGHT	WIRE TYPE
30	.027" to .029"	Stranded, Stranded
28	.030" to .032"	Tinned, Stranded Top Coated
26	.031" to .033"	1.52mm/.060in Maximum Insulation Diameter
24	.033" to .035"	Stranded, Stranded Tinned, Stranded Top
22	.033" to .035"	Coated 1.63mm/.064in Maximum Insulation Diameter
20	.033" to .035"	Stranded 0.5mm ² /.0078in ² Maximum Conductor Area. PVC Insulation, 1.70mm/.067in Maximum Diameter

<u>REVISION:</u> F	<u>ECR/ECN INFORMATION:</u> EC No: UDT2002-1319 DATE: 2002 / 04 / 30	<u>TITLE:</u> PRODUCT SPECIFICATION FOR SL CRIMP TERMINAL SERIES 70058	<u>SHEET No.</u> 2 of 8
<u>DOCUMENT NUMBER:</u> PS-70058	<u>CREATED / REVISED BY:</u> ACHAMMER	<u>CHECKED BY:</u> BRINKMAN	<u>APPROVED BY:</u> BRINKMAN



PRODUCT SPECIFICATION

“SL CRIMP TERMINAL”

3.0 RECOGNIZED AGENCY APPROVALS

3.1 Underwriters Laboratories: UL #E29179.

3.2 Canadian Standards Associations: CSA #LR19980.

4.0 MECHANICAL SPECIFICATIONS

4.1 Materials

4.1.1 Housing #70066-**** and #70450-**** is molded of black G.F. polyester 94V-0.

4.1.2 Terminal 70058-**** is a high strength copper alloy.

4.1.2.1 Finish .000200 min. electro-tin plate over .000100 min. copper plate overall.

4.1.2.2 Finish .000015 min. gold plate in selected area over .000050 min. nickel overall, with .000075 min. electro-tin lead (90/10) in selected area.

4.1.2.3 Finish .000030 min. gold in selected area over .000050 min. nickel plate overall, with .000075 min. electro-tin/lead (90/10) in selected area.

4.1.2.4 For special finish requirements, consult Molex marketing as to availability, cost and lead time.

4.2 Terminal Pull-Out Force, from Housing:

Must withstand gradual applied force of 4 pounds for 15 seconds.

4.3 Insulating Materials:

Temperature rating -40°C to +105°C

<u>REVISION:</u> F	<u>ECR/ECN INFORMATION:</u> EC No: UDT2002-1319 DATE: 2002 / 04 / 30	<u>TITLE:</u> PRODUCT SPECIFICATION FOR SL CRIMP TERMINAL SERIES 70058	<u>SHEET No.:</u> 3 of 8
<u>DOCUMENT NUMBER:</u> PS-70058	<u>CREATED / REVISED BY:</u> ACHAMMER	<u>CHECKED BY:</u> BRINKMAN	<u>APPROVED BY:</u> BRINKMAN



PRODUCT SPECIFICATION

“SL CRIMP TERMINAL”

4.4 Insertion/Withdrawal Forces:

AVERAGE INSERTION AND WITHDRAWAL FORCES *

PLATING TYPE	AFTER 1 CYCLE		AFTER 10 CYCLES		AFTER 25 CYCLES		AFTER 50 CYCLES	
	INSERTION FORCE	WITHDRAWAL FORCE	INSERTION FORCE	WITHDRAWAL FORCE	INSERTION FORCE	WITHDRAWAL FORCE	INSERTION FORCE	WITHDRAWAL FORCE
TIN	.32 lbf	.26 lbf	.23 lbf	.27 lbf	.24 lbf	.25 lbf	No	No
4.4.1	1.4 N	1.2 N	1.0 N	1.2 N	1.1 N	1.1 N	Data	data
GOLD	.34 lbf	.18 lbf	.27 lbf	.15 lbf	No	No	.25 lbf	.14 lbf
4.4.4	1.5 N	0.8 N	1.2 N	0.7 N	Data	Data	1.1 N	0.6 N

*Steel gage pins used to perform test:

Insertion Gage Pin: .0260+.0000-.0001

Withdrawal Gage Pin: .0240+.0001-.0000

4.4.1 “Tin” Plating System: .000200 Min. Tin over .000100 Min. copper

4.4.2 “Gold” Plating System: .000030 Min. Gold over .000050 Min. nickel

5.0 ELECTRICAL/ENVIRONMENTAL SPECIFICATIONS:

5.1 The following performance criteria is based on grouped, sequential testing.

5.2 All contact resistance values measured at 20 millivolts max. open circuit voltage and 5-15 milliamperes using the 4 point dry circuit method, with a Hewlett-Packard Milliohmmeter, Model #4328A.

5.3 All tin contact systems cycled 1, 5 & 25 times prior to grouped sequential testing, using (0.64) .025” square pins with .000200 min. tin over .000100 min. copper.

All gold contact systems cycled 1, 25 & 50 times prior to grouped sequential testing, using (0.64) .025” square pins with .000030 min. gold over .000050 min. nickel.

REVISION: F	ECR/ECN INFORMATION: EC No: UDT2002-1319 DATE: 2002 / 04 / 30	TITLE: PRODUCT SPECIFICATION FOR SL CRIMP TERMINAL SERIES 70058	SHEET No. 4 of 8
DOCUMENT NUMBER: PS-70058	CREATED / REVISED BY: ACHAMMER	CHECKED BY: BRINKMAN	APPROVED BY: BRINKMAN



PRODUCT SPECIFICATION

“SL CRIMP TERMINAL”

5.4 Group I Sequence: Mated Environment

	Test/Specifications	Test Severity/Duration
5.4.1	Thermal Shock IEC 68-2-14	-40°C to +105°C 30 minute dwell at each temperature is one cycle. 10 cycles
5.4.2	Thermal Aging Mil. Std. -202F, 108A	+105°C for 10 days
5.4.3	Cyclic Humidity Mil. Std. -202F, 106D without cold dip	Temperature cycles between +25°C to +65°C at 96% R.H. for 240 hours.
5.4.4	Flowers of Sulphur	Exposed to sulphur vapors for 24 hours at +65°C.
5.4.5	Contact Resistance not to exceed 15 milliohms, total	

<u>REVISION:</u> F	<u>ECR/ECN INFORMATION:</u> EC No: UDT2002-1319 DATE: 2002 / 04 / 30	<u>TITLE:</u> PRODUCT SPECIFICATION FOR SL CRIMP TERMINAL SERIES 70058	<u>SHEET No.</u> 5 of 8
<u>DOCUMENT NUMBER:</u> PS-70058	<u>CREATED / REVISED BY:</u> ACHAMMER	<u>CHECKED BY:</u> BRINKMAN	<u>APPROVED BY:</u> BRINKMAN



PRODUCT SPECIFICATION

"SL CRIMP TERMINAL"

5.5 Group II Sequence: Un-Mated Environment:

	Test/Specifications	Test Severity/Duration
5.5.1	Thermal Shock IEC 68-2-14	-40°C to +105°C 30 minute dwell at each temperature is one cycle. 10 cycles
5.5.2	Thermal Aging Mil. Std. -202F, 108A	+105°C for 10 days
5.5.3	Steady State Humidity Mil. Std. -202F, 103B Condition A	+40°C at 96% R.H. for 10 days
5.5.4	Flowers of Sulphur IEC 69-2-42	Exposed to sulphur vapors for 24 hours at +65°C
5.5.5	Mate once, contact resistance not to exceed 15 milliohms, total	

<u>REVISION:</u> F	<u>ECR/ECN INFORMATION:</u> EC No: UDT2002-1319 DATE: 2002 / 04 / 30	<u>TITLE:</u> PRODUCT SPECIFICATION FOR SL CRIMP TERMINAL SERIES 70058	<u>SHEET No.:</u> 6 of 8
<u>DOCUMENT NUMBER:</u> PS-70058	<u>CREATED / REVISED BY:</u> ACHAMMER	<u>CHECKED BY:</u> BRINKMAN	<u>APPROVED BY:</u> BRINKMAN



PRODUCT SPECIFICATION

“SL CRIMP TERMINAL”

5.6 Group III Sequence: Mated Environment Gold Contact System

	Test/Specifications	Test Severity/Duration
5.6.1	Steady State Humidity, Mil. Std. -202F, 103B Condition A	+40°C at 96% R.H. for 10 days.
5.6.2	Salt Spray Mil. Std. -202F 101D, Condition A	96 hours at +35°C, 5% sodium chloride
5.6.3	Physical Shock Mil. Std. -202F 213B	½ Sine Wave, 50G, 11MS pulse 3 shocks per axis for 240 hours.
5.6.4	Vibration Mil. Std. -202F, 201A	10-55-10 HZ, 1 minute cycles for 2 hours in each axis. .03 inch excursion, 10G.
5.6.5	Contact resistance not to exceed 15 milliohms, total	

<u>REVISION:</u> F	<u>ECR/ECN INFORMATION:</u> EC No: UDT2002-1319 DATE: 2002 / 04 / 30	<u>TITLE:</u> PRODUCT SPECIFICATION FOR SL CRIMP TERMINAL SERIES 70058	<u>SHEET No.</u> 7 of 8
<u>DOCUMENT NUMBER:</u> PS-70058	<u>CREATED / REVISED BY:</u> ACHAMMER	<u>CHECKED BY:</u> BRINKMAN	<u>APPROVED BY:</u> BRINKMAN



PRODUCT SPECIFICATION

“SL CRIMP TERMINAL”

5.7 Group IV Sequence: Mated Electrical

	Test/Specifications	Test Severity/Duration
5.7.1	Steady State Humidity, Mil. Std. -202F, 103B Condition A	+40°C at 96% R.H. for 10 days.
5.7.2	Temperature Rise	Increase current to achieve 30°C rise above ambient. Dwell for 48 hours at that current.
5.7.3	Current Ratings:	30 Awg - 0.7A 36 Awg - 0.21A 28 Awg - 1.2A 34 Awg - 0.32A 26 Awg - 1.8A 32 Awg - .045A 24 Awg - 3.0A 22 Awg - 3.0A

5.8 Insulation Resistance: Per Mil. Std. 202, Method 302, Condition B. Resistance measured after sequence 5.5.1 thru 5.5.5 to be no less than 10K megohms.

5.9 Dielectric Strength: AC voltage increased until breakdown.

Voltage measured after sequence 5.5.1 thru 5.5.5 to be no less than 600 volts AC R.M.S. for 1 minute at sea level to 5,000 feet.

5.10 Capacitance: Less than 1.2 pico-farads.

<u>REVISION:</u> F	<u>ECR/ECN INFORMATION:</u> EC No: UDT2002-1319 DATE: 2002 / 04 / 30	<u>TITLE:</u> PRODUCT SPECIFICATION FOR SL CRIMP TERMINAL SERIES 70058	<u>SHEET No.</u> 8 of 8
<u>DOCUMENT NUMBER:</u> PS-70058	<u>CREATED / REVISED BY:</u> ACHAMMER	<u>CHECKED BY:</u> BRINKMAN	<u>APPROVED BY:</u> BRINKMAN

NOTES:

1. TERMINAL TO BE USED IN HOUSINGS 70066-**** AND 70450-****
2. REFER TO PRODUCT SPECIFICATION PS-70058
3. REFER TO MOLEX OPERATIONS AND SERVICE MANUAL FOR CRIMP DETAILS
4. TERMINAL TO BE USED WITH (0.64)/.025 SQUARE PINS
5. TERMINAL TO BE USED WITH 22-24 AWG STRANDED WIRE WITH (1.63)/.064 MAX. DIA. INSULATION
6. TERMINALS SUPPLIED IN REEL FORM
7. CRIMP SIZE INDICATOR C=22-24 AWG

*THE PRIMARY SHIPPING CARTON WILL BE LABELED "COMPLIANT TO RoHS DIRECTIVE 2002/95/EC AND ELV ANNEX II OF DIRECTIVE 2000/53/EC". CARTONS WITHOUT THIS LABEL MAY CONTAIN PRODUCT WITH LEAD.

PLATING:

.000150 MIN. TIN PLATE
OVER NICKEL PLATE.

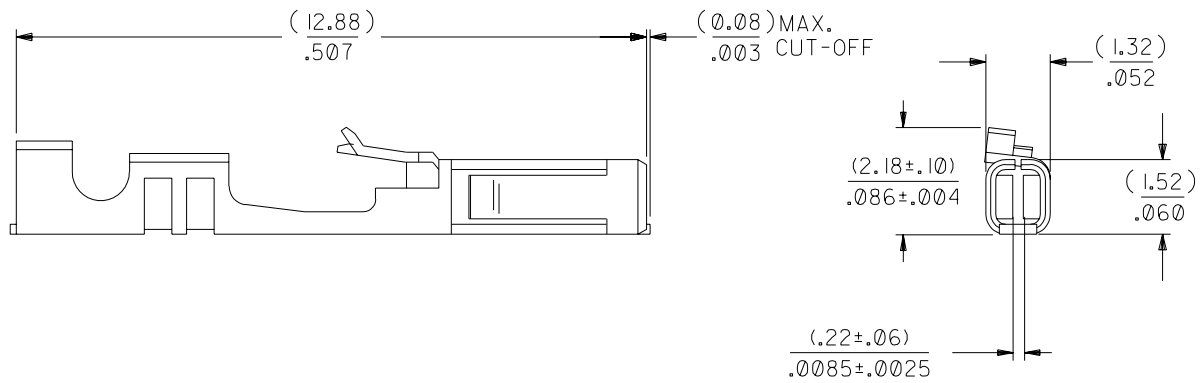
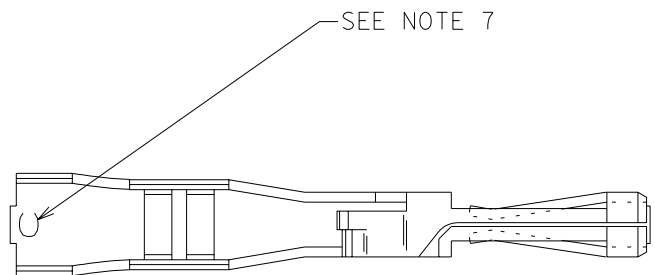

		DI	REVISED ECR #U80270 MCGRATH 97/07/31
E	LEAD FREE UCP2004-1769 RWHITE 04/03/11	D	164 PLATING WAS 102 PER ECR # U31149 08/17/93 REED
D2	ADD. CRP. SIZE&NOTE 7 ECN UDT1998-0183 MQWANG 04/16/98	C	REDRAWN & REVISED PER ECR #U81133 03/02/88 MJM/JAS
LTR.	REVISIONS	LTR.	REVISIONS

DIMENSIONS SHOWN (METRIC) INCH	
UNLESS OTHERWISE SPECIFIED TOLERANCES: ANGULAR ± 1/2°	
3 PLACE	± .005 ---
2 PLACE	± .01 ± 0.13
1 PLACE	--- ± 0.25
DRAFT WHERE APPLICABLE MUST REMAIN WITHIN DIMENSIONS	
DRWG. BY: JAS	CHK'D. BY:
APP'D. BY:	SCALE 10:1

▽ = 0	▼ = 0	REVISE ONLY ON CAD SYSTEM	
TITLE TERMINAL - BOX/CRIMP			
MOLEX INCORPORATED LISLE, ILL. 60532 U.S.A.		SHEET NO. 1 OF 1	DATE 03/02/88
PART NO. 016-02-0086		DRWG. NO. SD-70058-0022	
FILE NAME S70058C3 DGN	THIS DRAWING CONTAINS INFORMATION THAT IS PROPRIETARY TO MOLEX INC. AND SHOULD NOT BE USED WITHOUT WRITTEN PERMISSION.		DIV. SIZE DA B