

Distributed by:

JAMECO[®]
ELECTRONICS

www.Jameco.com ♦ 1-800-831-4242

The content and copyrights of the attached
material are the property of its owner.

Jameco Part Number 752042

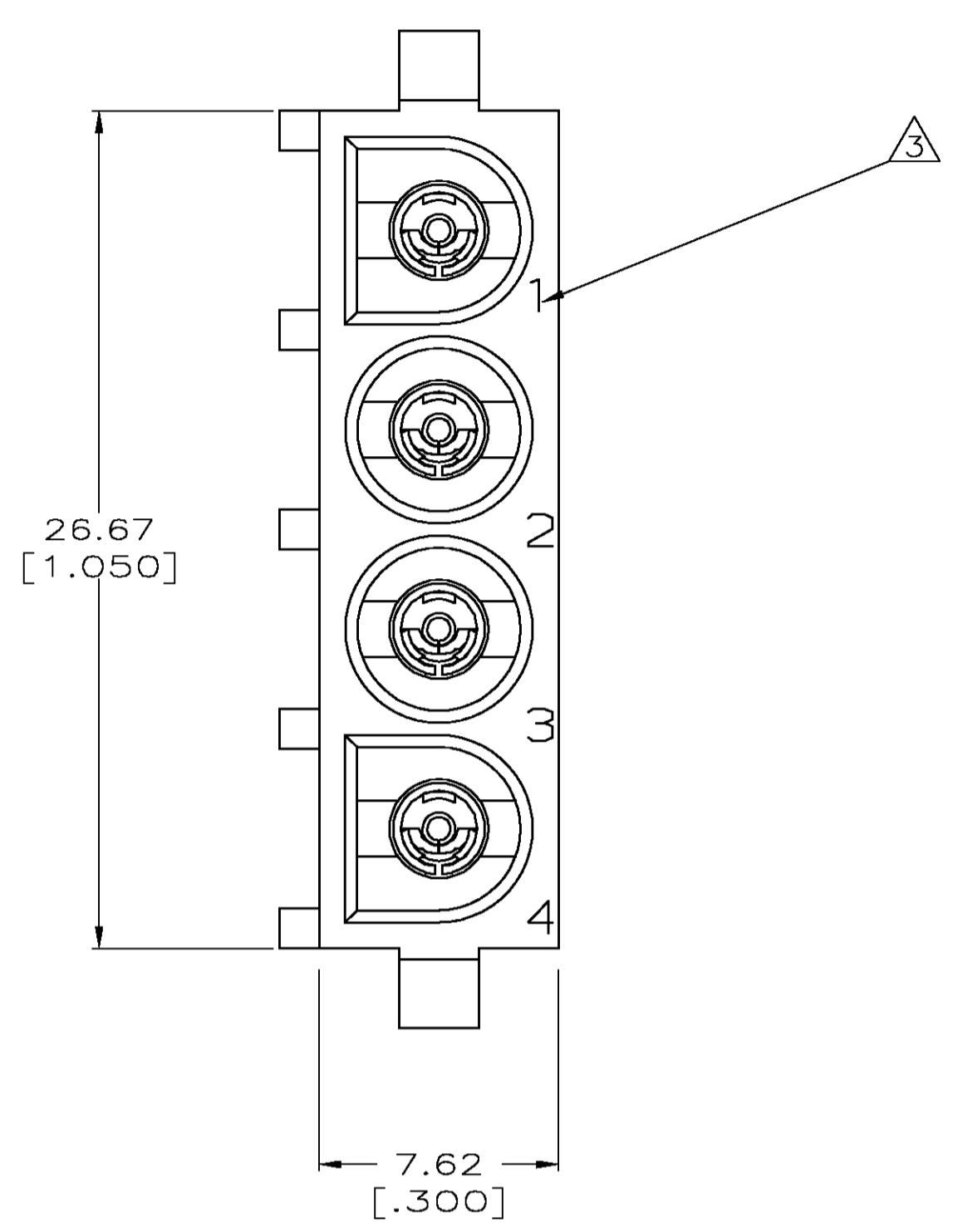
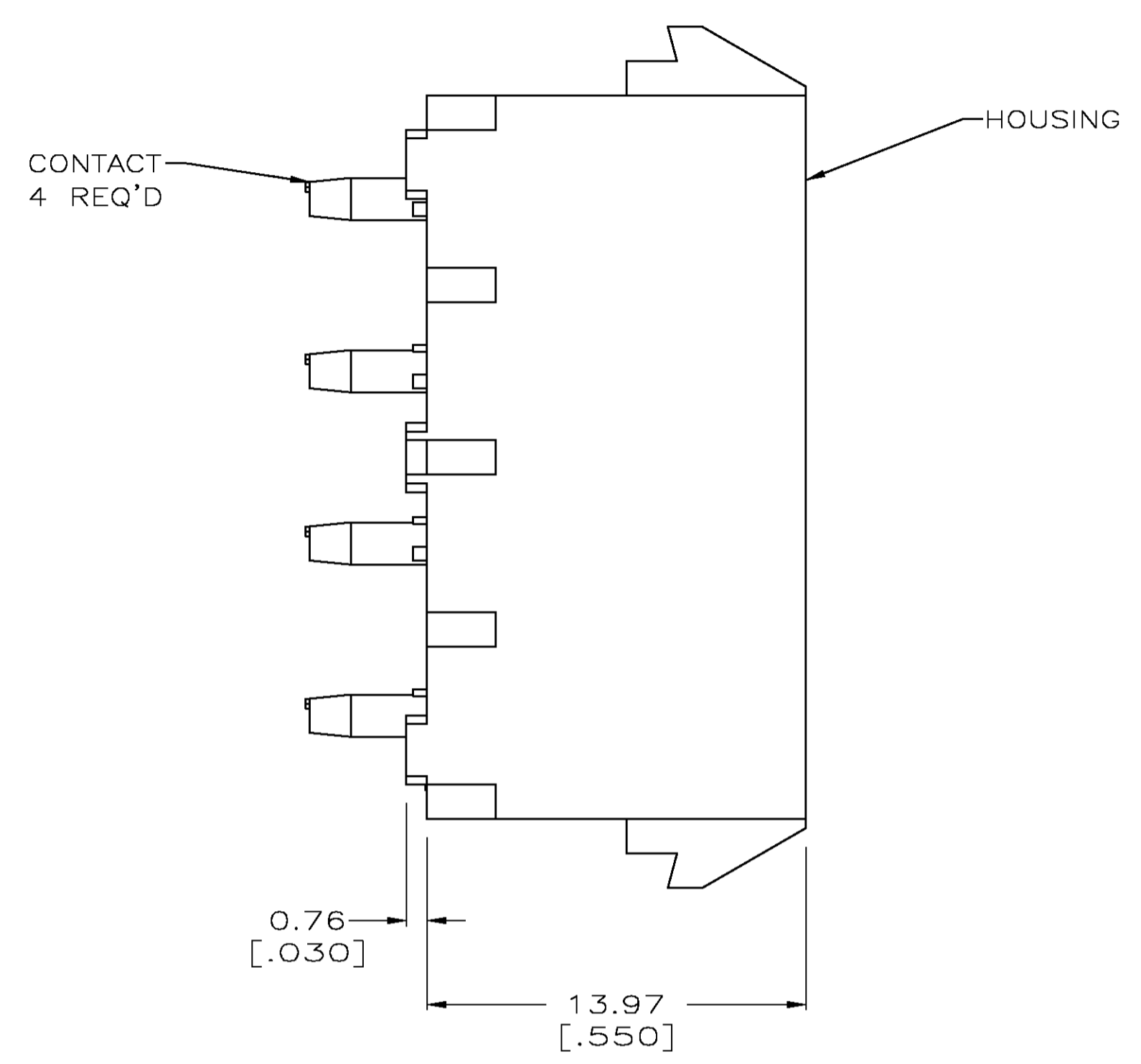
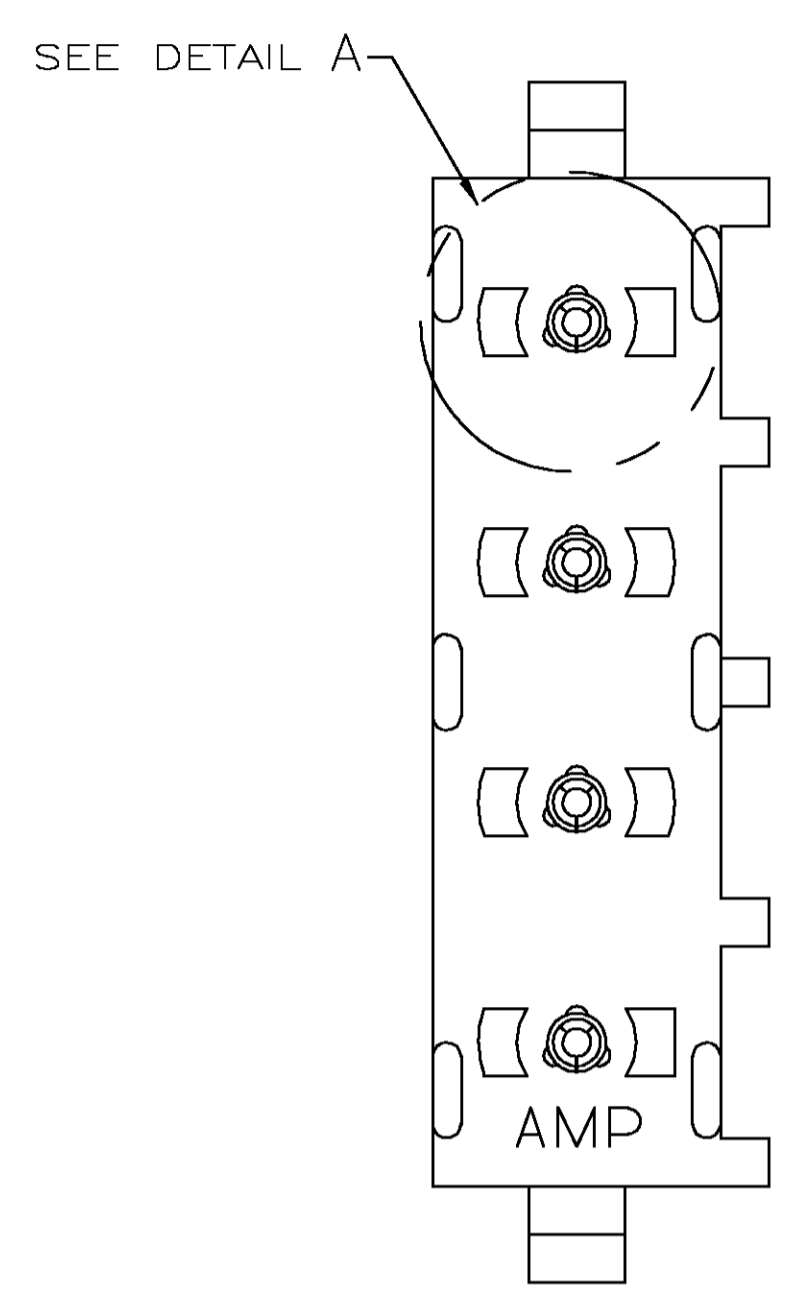

- PARTS COMPLY TO AMP SOLDERABILITY SPECIFICATION 109-11-3.
- CONTACT IS PLATED OVERALL WITH 0.00127 [.000050] NICKEL, THEN 0.00076 [.000030] GOLD OVER CONTACT LENGTH INDICATED AND MATTE TIN LEAD ON SOLDER TAIL END.
- CIRCUIT IDENTIFICATION CHARACTERS ARE ADJACENT TO THE INDICATED CAVITIES, BUT LOCATION AND ORIENTATION MAY DIFFER FROM PRINT.
- DIMENSIONS IN BRACKETS ARE IN INCHES.
- DRAIN HOLES LOCATED AS SHOWN. OPTIONAL CONSTRUCTION - ALL DRAIN HOLES LOCATED 90° AS SHOWN IN DETAIL A.
- CONTACT IS PLATED OVERALL WITH 0.00127 [.000050] NICKEL, THEN 0.00076 [.000030] GOLD OVER CONTACT LENGTH INDICATED AND MATTE TIN ON SOLDER TAIL END.

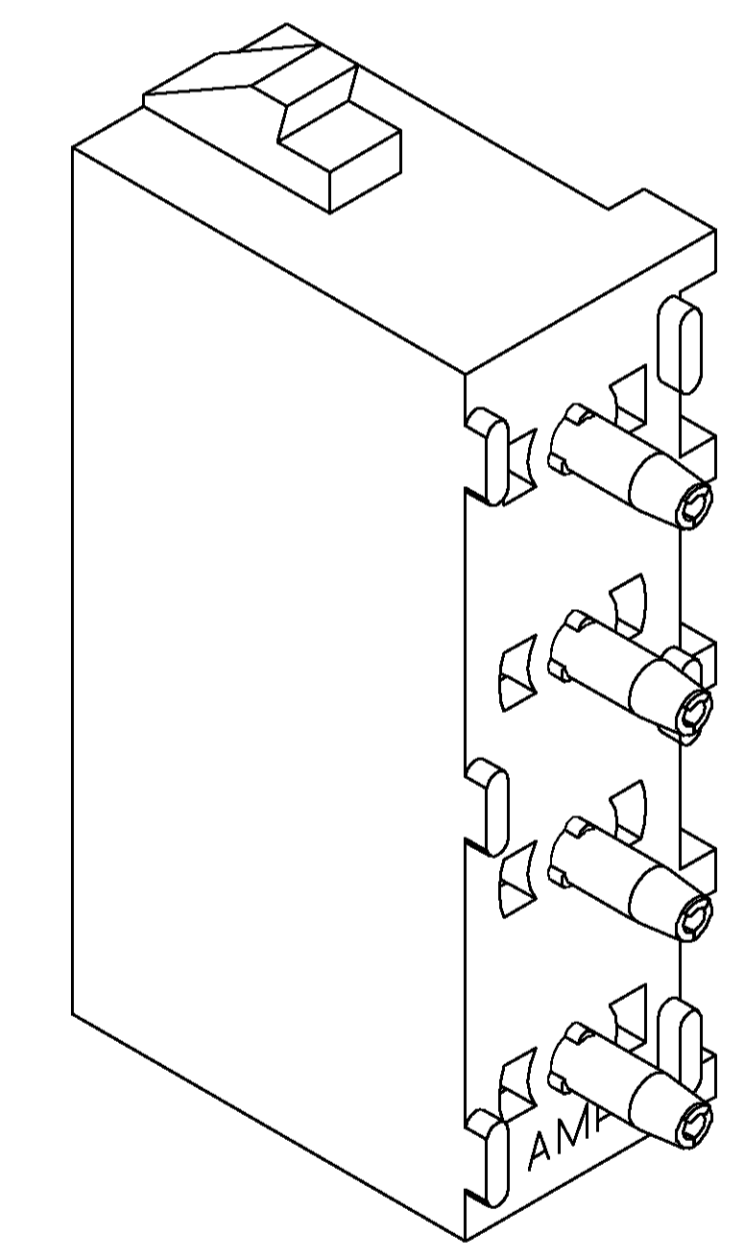
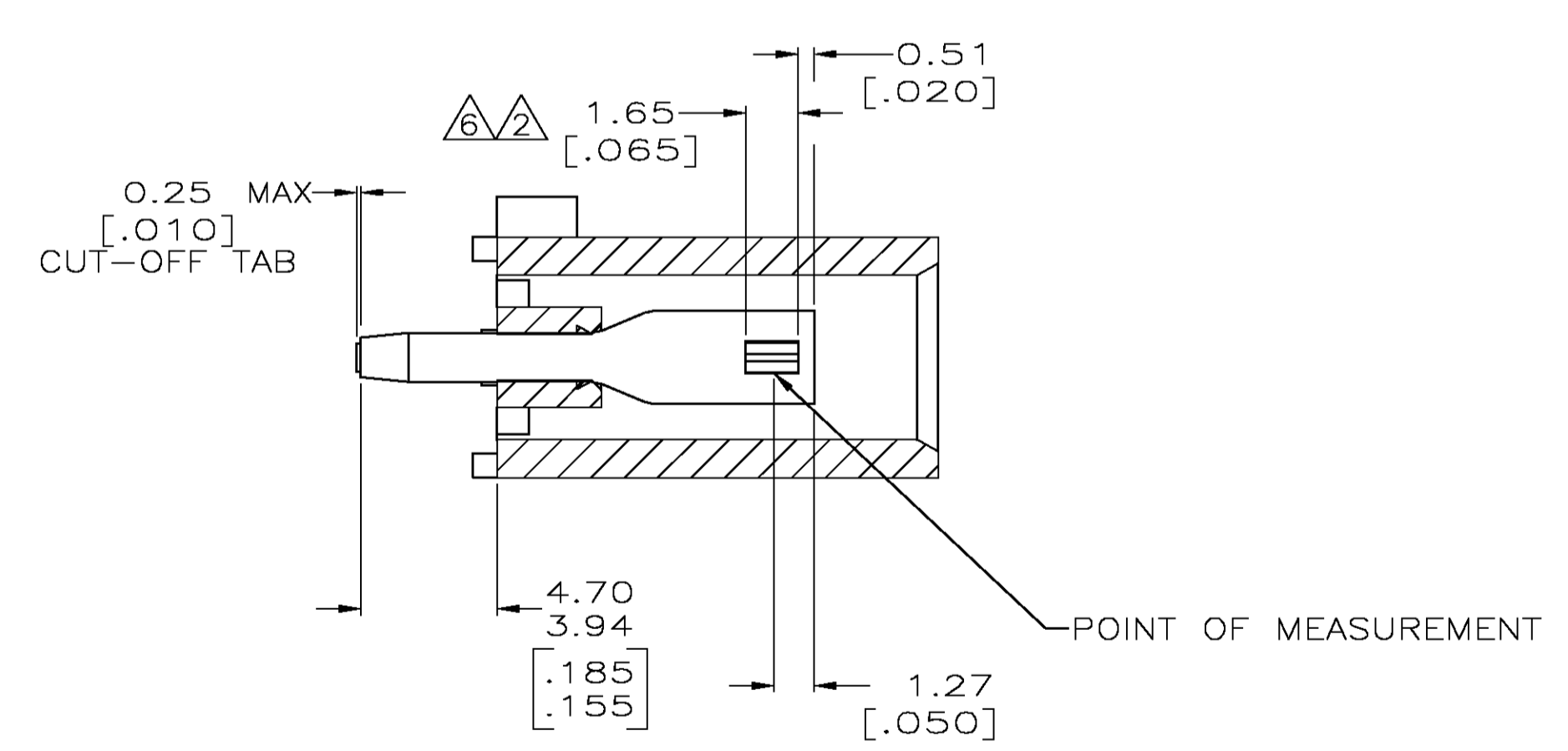

3-DIMENSIONAL MODEL NTS

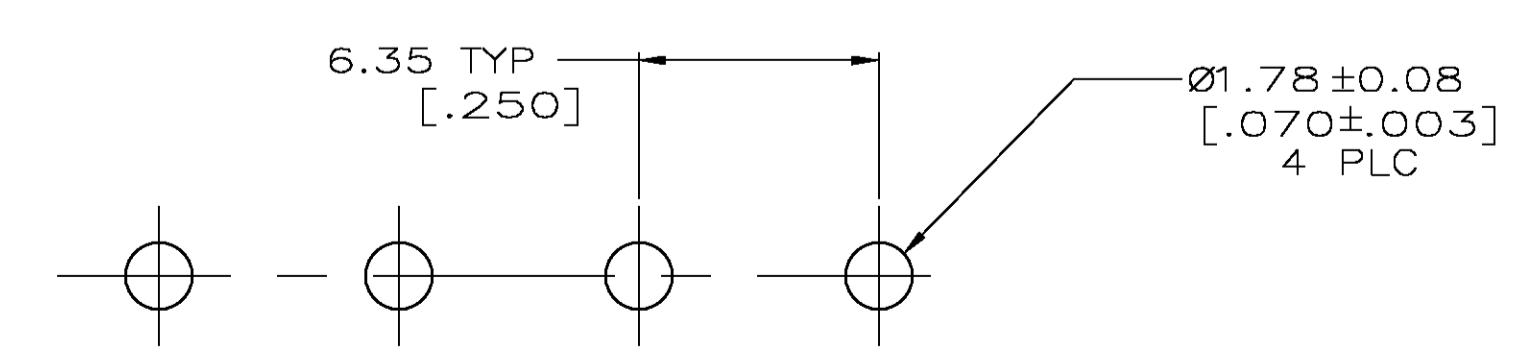
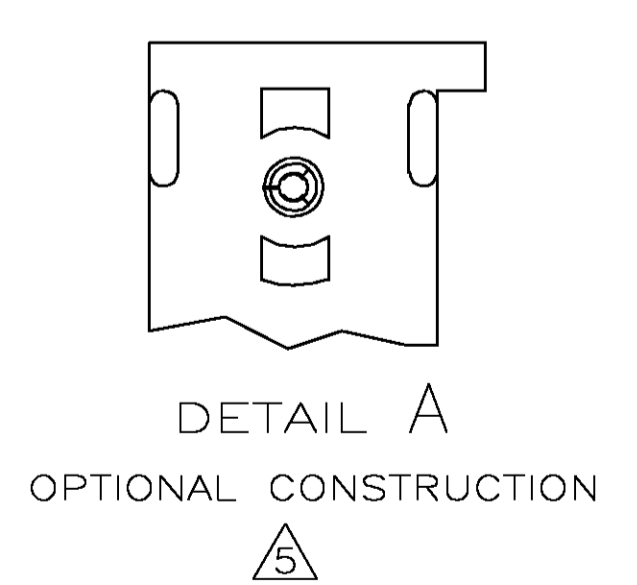

RECOMMENDED MOUNTING HOLE PATTERN FOR 1.57 [.062] THICK P.C. BOARD

PHOSPHOR BRONZE, GOLD	NYLON, UL94V-0, WHITE	350826-4
PHOSPHOR BRONZE, GOLD	NYLON, UL94V-0, WHITE	350826-2
PHOSPHOR BRONZE, PRE-TIN	NYLON, UL94V-0, WHITE	350826-1
CONTACT MATERIAL AND FINISH	HOUSING MATERIAL	PART NUMBER

METRIC

THIS DRAWING IS A CONTROLLED DOCUMENT.

DIMENSIONS: mm [INCHES]	TOLERANCES UNLESS OTHERWISE SPECIFIED:	DMN: B. LEWIS 10-02-98	APVD: M. TRULL 10-02-98	NAME: Tyco Electronics Corporation, Greensboro, NC 27409
0 PLC ± -	1 PLC ± -	2 PLC ± 0.13 [.005]	3 PLC ± -	4 PLC ± -
ANGLES ± 0.30°	FINISH: SEE TABLE	SIZE: A1	SCALE: 5:1	RESTRICTED TO: -
MATERIAL: SEE TABLE	FINISH: SEE TABLE	WEIGHT: -	DRAWING NO: 00779	CUSTOMER DRAWING

SOCKET HEADER ASSEMBLY, 4 CIRCUIT UNIVERSAL MATE-N-LOK™

SCALE 5:1 SHEET 1 OF 1 REV P