

Distributed by:

**JAMECO**<sup>®</sup>  
ELECTRONICS

**www.Jameco.com ♦ 1-800-831-4242**

The content and copyrights of the attached  
material are the property of its owner.

Jameco Part Number 882242

## FEATURES AND SPECIFICATIONS

### Features and Benefits

- Peg-mounted for increased board retention
- Low profile for space constraints
- Positive housing locks
- Fully isolated terminals to protect contacts from damage

### Reference Information

Product Specification: PS-5556-0001  
 Packaging: Tray or bag  
 UL File No.: E29179  
 CSA File No.: LR19980  
 TUV License No.: R75142  
 Mates With: [5557](#) dual row receptacle  
 Designed In: Millimeters

### Electrical

Voltage: 600V  
 Current: (Used with 16 AWG)

Circuits	2-3	4-6	7-10	12-24
Amperes-Jr.	9	8	7	6
Amperes-HCS	12	11	10	9

Contact Resistance: 10mΩ max.  
 Dielectric Withstanding Voltage: 1500V  
 Insulation Resistance: 1000 MΩ min.

### Mechanical

Insertion Force to PCB: 5.0kg max.  
 Mating Force: 0.7kg (1.54 lb) max.  
 Unmating Force: 0.35kg (0.7 lb) min.  
 Normal Force: 200g min.  
 Durability: 30 cycles

### Physical

Housing: 6/6 nylon, UL 94V-2 or 94V-0  
 Contact: Brass  
 Plating: Tin, select Gold or overall Gold  
 Operating Temperature: -40 to +105°C

# molex® 4.20mm (.165") Pitch Mini-Fit, Jr.™ Header

## 5569

## Right Angle, Dual Row With Pegs

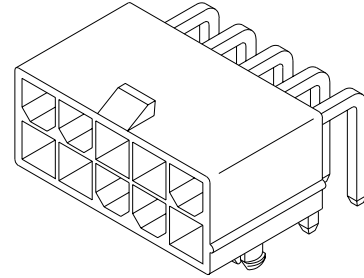

Power Connectors

F

## CATALOG DRAWING (FOR REFERENCE ONLY)

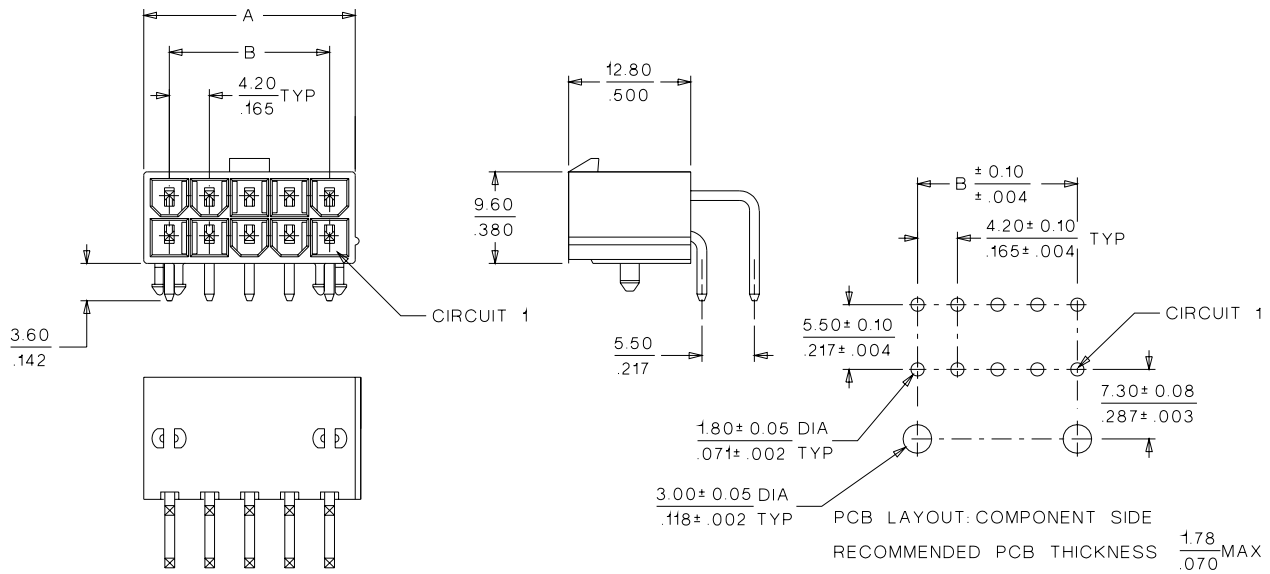

## ORDERING INFORMATION AND DIMENSIONS

Circuits	Order No.						Dimension	
	Tin Plated		Gold Plated (30μ")		Select Gold Plated (30μ")		A	B
	94V-2	94V-0	94V-2	94V-0	94V-2	94V-0		
2	● 39-30-1020	● 39-30-0020	39-30-1021	39-30-1022	39-30-0023	39-30-0024	5.40 (.213)	
4	● 39-30-1040	● 39-30-0040	39-30-1041	39-30-1042	39-30-0043	39-30-0044	9.60 (.378)	4.20 (.165)
6	● 39-30-1060	● 39-30-0060	39-30-1061	39-30-1062			13.80 (.543)	8.40 (.331)
8	● 39-30-1080	● 39-30-0080	39-30-1081	39-30-1082			18.00 (.709)	12.60 (.496)
10	● 39-30-1100	● 39-30-0100	39-30-1101	39-30-1102			22.20 (.874)	16.80 (.661)
12	● 39-30-1120	● 39-30-0120	39-30-1121	39-30-1122			26.40 (1.039)	21.00 (.827)
14	● 39-30-1140	● 39-30-0140	39-30-1141	39-30-1142			30.60 (1.205)	25.20 (.992)
16	● 39-30-1160	● 39-30-0160	39-30-1161	39-30-1162			34.80 (1.370)	29.40 (1.158)
18	● 39-30-1180		39-30-1181				39.00 (1.535)	33.60 (1.323)
20	● 39-30-1200	● 39-30-0200	39-30-1201	39-30-1202			43.20 (1.701)	37.80 (1.488)
22	● 39-30-1220		39-30-1221				47.40 (1.866)	42.00 (1.654)
24	● 39-30-1240	● 39-30-0240	39-30-1241	39-30-1242			51.60 (2.031)	46.20 (1.819)

● US Standard Product, available through Molex franchised distributors



# PRODUCT SPECIFICATION

## MINI-FIT JR.

### 1.0 SCOPE

This Product Specification covers performance requirements for the MINI-FIT JR. 4.20 mm (.165 inch) centerline (pitch) printed circuit board (PCB) connector series with Tin or Gold plating, and The MINI-FIT JR. connector series terminated with 16 to 28 AWG wire using Crimp technology with Tin or Gold plating.

### 2.0 PRODUCT DESCRIPTION

#### 2.1 PRODUCT NAME AND SERIES NUMBER (S)

<u>PRODUCT NAME</u>	<u>PART NUMBER</u>
Female Crimp Terminal	5556-****
Male Crimp Terminal	5558-****
Receptacle Housing	5557-****
Plug Housing	5559-****
Vertical Header Assembly	5566-****
Right Angle Header Assembly	5569-****

#### 2.2 DIMENSIONS, MATERIALS, PLATINGS AND MARKINGS

See the appropriate sales drawings for the information on dimensions, materials, platings and markings.

#### 2.3 SAFETY AGENCY APPROVALS

UL File: E29179  
CSA Certificate: LR 19980  
TUV Certificate: R75142-8

### 3.0 APPLICABLE DOCUMENTS AND SPECIFICATIONS

See sales drawings and the other sections of this specification for the necessary referenced documents and specifications

### 4.0 RATINGS

#### 4.1 VOLTAGE

600 Volts AC (RMS) (or 600 Volts DC)

#### 4.2 CURRENT AND APPLICABLE WIRES

<b>Maximum Insulation Diameter and Applicable Wire Gauges</b>	16 AWG: 3.10/. 122 MAXIMUM
	18-24 AWG: 3.10/. 122 MAXIMUM
	22-28 AWG: 1.80/. 071 MAXIMUM

<b>REVISION:</b> <b>C</b>	<b>EGR/ECN INFORMATION:</b> EC No: <b>UCP2004-2349</b> DATE: <b>2004 / 05 / 25</b>	<b>TITLE:</b> <b>PRODUCT SPECIFICATION FOR MINI-FIT JR. CONNECTOR SYSTEM</b>	<b>SHEET No.</b> <b>1 of 5</b>
<b>DOCUMENT NUMBER:</b> <b>PS-5556-001</b>	<b>CREATED / REVISED BY:</b> <b>BANDURA</b>	<b>CHECKED BY:</b> <b>BANDURA</b>	<b>APPROVED BY:</b> <b>MARGULIS</b>



# PRODUCT SPECIFICATION

## 4.2 CURRENT AND APPLICABLE WIRES (continued)

MAXIMUM CURRENT RATING (Amperes)									
Brass					Phosphor Bronze				
Wire \ Ckt. Size	2 & 3	4 - 6	7 - 10	12 - 24	Wire \ Ckt. Size	2 & 3	4 - 6	7 - 10	12 - 24
AWG #16	9	8	7	6	AWG #16	8	7	6	5
AWG #18	9	8	7	6	AWG #18	8	7	6	5
AWG #20	7	6	5	5	AWG #20	6	5	4	4
AWG #22	5	4	4	4	AWG #22	4	3	3	3
AWG #24	4	3	3	3	AWG #24	3	2	2	2
AWG #26	3	2	2	2	AWG #26	2	1	1	1
AWG #28	2	1	1	1	AWG #28	1	1	1	1

## 4.3 TEMPERATURE

Operating: \* - 40°C to + 105°C

Nonoperating: - 40°C to + 105°C

\*Including 30°C terminal temperature at rated current

## 5.0 PERFORMANCE

### 5.1 ELECTRICAL REQUIREMENTS

ITEM	DESCRIPTION	TEST CONDITION	REQUIREMENT
1	<b>Contact Resistance (Low Level)</b>	Mate connectors: apply a maximum voltage of 20 mV and a current of 100 mA. Wire resistance shall be removed from the measured value.	10 milliohms MAXIMUM [initial]
2	<b>Contact Resistance @ Rated Current</b>	Mate connectors: apply a maximum voltage of 20 mV at rated current.	10 milliohms MAXIMUM [initial]
3	<b>Contact Resistance of Wire Termination (Low Level)</b>	Terminate the applicable wire to the terminal and measure wire using a voltage of 20 mV and a current of 100 mA.	5 milliohms MAXIMUM [initial]
4	<b>Insulation Resistance</b>	Mate connectors: apply a voltage of 500 VDC between adjacent terminals and between terminals to ground.	1000 Megohms MINIMUM

REVISION: <b>C</b>	EGR/ECN INFORMATION: EC No: <b>UCP2004-2349</b> DATE: <b>2004 / 05 / 25</b>	TITLE: <b>PRODUCT SPECIFICATION FOR MINI-FIT JR. CONNECTOR SYSTEM</b>	SHEET No. <b>2 of 5</b>
DOCUMENT NUMBER: <b>PS-5556-001</b>		CREATED / REVISED BY: <b>BANDURA</b>	CHECKED BY: <b>BANDURA</b>
		APPROVED BY: <b>MARGULIS</b>	



# PRODUCT SPECIFICATION

## 5.1 ELECTRICAL REQUIREMENTS (continued)

ITEM	DESCRIPTION	TEST CONDITION	REQUIREMENT
5	<b>Dielectric Withstanding Voltage</b>	Mate connectors: apply a voltage of 1500 VAC for 1 minute between adjacent terminals and between terminals to ground.	No breakdown. Current leakage < 5 mA
6	<b>Temperature Rise (via Current Cycling)</b>	Mate connectors. Measure the temperature rise at the rated current after 96 hours, during current cycling (45 minutes ON and 15 minutes OFF per hour) for 240 hours, and after final 96-hour steady state.	Temperature rise: +30°C MAXIMUM

## 5.2 MECHANICAL REQUIREMENTS

ITEM	DESCRIPTION	TEST CONDITION	REQUIREMENT
1	<b>Terminal Insertion and Withdrawal Forces</b>	Insert and withdraw terminal (male to female) at a rate of 25 ± 6 mm (1 ± ¼ inch) per minute.	14.7 N (3.30 lbf) MAXIMUM insertion force & 1.0 N (0.02 lbf) MINIMUM withdrawal force
2	<b>Terminal Retention Force (in Housing)</b>	Axial pullout force on the terminal in the housing at a rate of 25 ± 6 mm (1 ± ¼ inch) per minute.	30 N (6.74 lbf) MINIMUM retention force
3	<b>Durability</b>	Mate connectors up to 30 cycles at a maximum rate of 10 cycles per minute prior to Environmental Tests.	20 milliohms MAXIMUM
4	<b>Vibration (Random)</b>	Mate connectors and vibrate per EIA 364-28, test condition VII.	10 milliohms MAXIMUM (change from initial) & Discontinuity < 1 microsecond
5	<b>Shock (Mechanical)</b>	Mate connectors and shock at 50 g's with ½ sine wave (11 milliseconds) shocks in the ±X, ±Y, ±Z axes, (18 shocks total).	20 milliohms MAXIMUM & Discontinuity < 1 microsecond
6	<b>Wire Pullout Force (Axial)</b>	Apply an axial pullout force on the wire at a rate of 25 ± 6 mm (1 ± ¼ inch).	16 Awg = 88.0 N (19.8 lbf) Min. 18 Awg = 88.0 N (19.8 lbf) Min. 20 Awg = 59.0 N (13.3 lbf) Min. 22 Awg = 39.0 N (8.78 lbf) Min. 24 Awg = 29.0 N (6.52 lbf) Min. 26 Awg = 19.0 N (4.27 lbf) Min. 28 Awg = 9.80 N (2.20 lbf) Min.

REVISION: <b>C</b>	EGR/ECN INFORMATION: EC No: UCP2004-2349 DATE: 2004 / 05 / 25	TITLE: <b>PRODUCT SPECIFICATION FOR MINI-FIT JR. CONNECTOR SYSTEM</b>	SHEET No. <b>3 of 5</b>
DOCUMENT NUMBER: <b>PS-5556-001</b>	CREATED / REVISED BY: <b>BANDURA</b>	CHECKED BY: <b>BANDURA</b>	APPROVED BY: <b>MARGULIS</b>



# PRODUCT SPECIFICATION

## 5.2 MECHANICAL REQUIREMENTS (continued)

7	<b>Terminal Insertion Force (into Housing)</b>	Apply an axial insertion force on the terminal at a rate of $25 \pm 6$ mm ( $1 \pm \frac{1}{4}$ inch).	15.0 N (3.37 lbf) MAXIMUM insertion force
8	<b>Normal Force</b>	Apply a perpendicular force.	0.49 N (50 grams) MINIMUM [Gold (noble) plating] OR 1.47 N (150 grams) MINIMUM [Tin (non-noble) plating]
9	<b>PCB Engagement and Separation Forces</b>	Engage and separate a connector at a rate of $25 \pm 6$ mm ( $1 \pm \frac{1}{4}$ inch) per minute. (Applies to parts with PCB retention features only)	49.0 N (11.0 lbf) MAXIMUM insertion force & 10.0 N (2.24 lbf) MINIMUM withdrawal force
10	<b>Panel Insertion and Withdrawal Forces</b>	Insert and withdraw a connector at a rate of $25 \pm 6$ mm ( $1 \pm \frac{1}{4}$ inch) per minute. (Applies to parts with panel retention features only)	225 N (50.7 lbf) MAXIMUM insertion force & 157 N (35.3 lbf) MINIMUM withdrawal force
11	<b>Pin Retention Force</b>	Apply axial push force at the speed rate of $25 \pm 3$ mm/minute.	1.0 KGF MIN.
12	<b>Thumb latch Operation Force</b>	Depress latch at a speed rate of 25.4 mm/minute.	1.7 KGF MAX.
13	<b>Thumb latch Yield Strength</b>	Mate loaded connectors fully. Pull apart via wires at a speed rate of 25.4 mm/minute.	7.0 KGF MIN.

<u>REVISION:</u> <b>C</b>	<u>EGR/ECN INFORMATION:</u> EC No: <b>UCP2004-2349</b> DATE: <b>2004 / 05 / 25</b>	<u>TITLE:</u> <b>PRODUCT SPECIFICATION FOR MINI-FIT JR. CONNECTOR SYSTEM</b>	<u>SHEET No.</u> <b>4 of 5</b>
<u>DOCUMENT NUMBER:</u> <b>PS-5556-001</b>	<u>CREATED / REVISED BY:</u> <b>BANDURA</b>	<u>CHECKED BY:</u> <b>BANDURA</b>	<u>APPROVED BY:</u> <b>MARGULIS</b>



# PRODUCT SPECIFICATION

## 5.3 ENVIRONMENTAL REQUIREMENTS (continued)

ITEM	DESCRIPTION	TEST CONDITION	REQUIREMENT
1	<b>Thermal Shock</b>	Mate connectors: expose for 5 cycles Between temperatures -55 and 105° C; Dwell 0.5 hours at each temperature.	20 milliohms MAXIMUM Visual: No Damage Dielectric Strength per 5.1.5 Insulation Resistance per 5.1.4
2	<b>Thermal Aging</b>	Mate connectors; expose to: 96 hours at 105 ± 2°C	20 milliohms MAXIMUM & Visual: No Damage
3	<b>Humidity (Steady State)</b>	Mate connectors: expose to a temperature of 60 ± 2°C with a relative humidity of 90-95% for 96 hours.	20 milliohms MAXIMUM Dielectric Strength per 5.1.5 Insulation Resistance per 5.1.4 Visual: No Damage
4	<b>Solderability</b>	Per SMES-152	Solder coverage: 95% MINIMUM (per SMES-152)
5	<b>Solder Resistance</b>	Dip connector terminals tail in solder: Solder Duration: 5 ± 0.5 seconds; Solder Temperature: 260 ± 5°C	Visual: No Damage to insulator material
6	<b>Cold Resistance</b>	Mate connectors: Duration; 96 hours; Temperature: -40 ± 3°C	20 milliohms MAXIMUM Visual: No Damage
7	<b>Corrosive Atmosphere: Sulfur Dioxide Gas (SO<sub>2</sub>)</b>	Mate connectors: Duration; 24 hours exposure. Atmosphere: 50 parts per million (ppm) SO <sub>2</sub> Gas. Temperature: 40 ± 3°C	20 milliohms MAXIMUM Visual: No Damage

## 6.0 PACKAGING

Parts shall be packaged to protect against damage during handling, transit and storage.

REVISION: <b>C</b>	EGR/ECN INFORMATION: EC No: UCP2004-2349 DATE: 2004 / 05 / 25	TITLE: <b>PRODUCT SPECIFICATION FOR MINI-FIT JR. CONNECTOR SYSTEM</b>	SHEET No. <b>5 of 5</b>
DOCUMENT NUMBER: <b>PS-5556-001</b>	CREATED / REVISED BY: <b>BANDURA</b>	CHECKED BY: <b>BANDURA</b>	APPROVED BY: <b>MARGULIS</b>



# PRODUCT SPECIFICATION

<u>REVISION:</u> <b>C</b>	<u>EGR/ECN INFORMATION:</u> EC No: <b>UCP2004-2349</b> DATE: <b>2004 / 05 / 25</b>	<u>TITLE:</u> <b>PRODUCT SPECIFICATION FOR MINI-FIT JR. CONNECTOR SYSTEM</b>	<u>SHEET No.</u> <b>6 of 5</b>
<u>DOCUMENT NUMBER:</u> <b>PS-5556-001</b>	<u>CREATED / REVISED BY:</u> <b>BANDURA</b>	<u>CHECKED BY:</u> <b>BANDURA</b>	<u>APPROVED BY:</u> <b>MARGULIS</b>





# PRODUCT SPECIFICATION

<u>REVISION:</u> <b>C</b>	<u>EGR/ECN INFORMATION:</u> <u>EC No:</u> <b>UCP2004-2349</b> <u>DATE:</u> <b>2004 / 05 / 25</b>	<u>TITLE:</u> <b>PRODUCT SPECIFICATION FOR MINI-FIT JR. CONNECTOR SYSTEM</b>	<u>SHEET No.</u> <b>7 of 5</b>
<u>DOCUMENT NUMBER:</u> <b>PS-5556-001</b>	<u>CREATED / REVISED BY:</u> <b>BANDURA</b>	<u>CHECKED BY:</u> <b>BANDURA</b>	<u>APPROVED BY:</u> <b>MARGULIS</b>

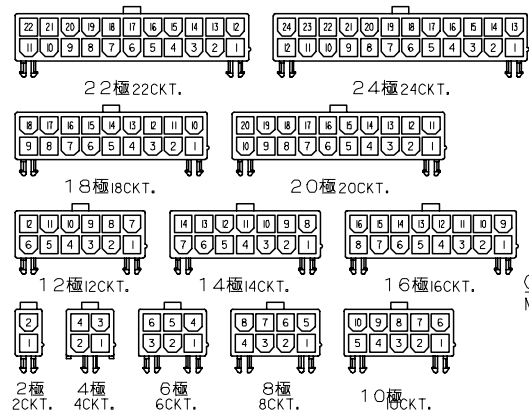
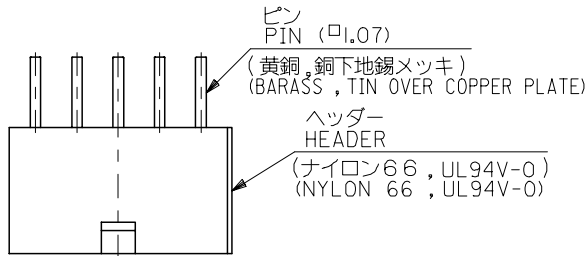

極数別レイアウト図  
LAYOUT ACCORDING TO CKT NO.  
(SCALE : 1:1)

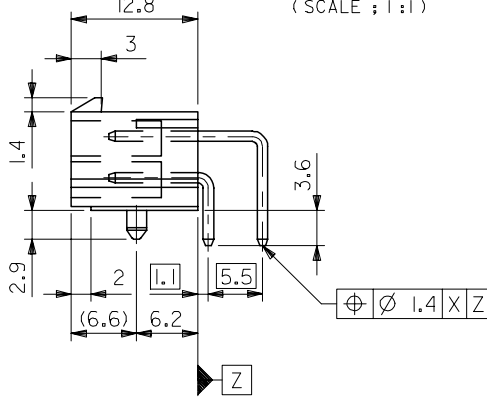
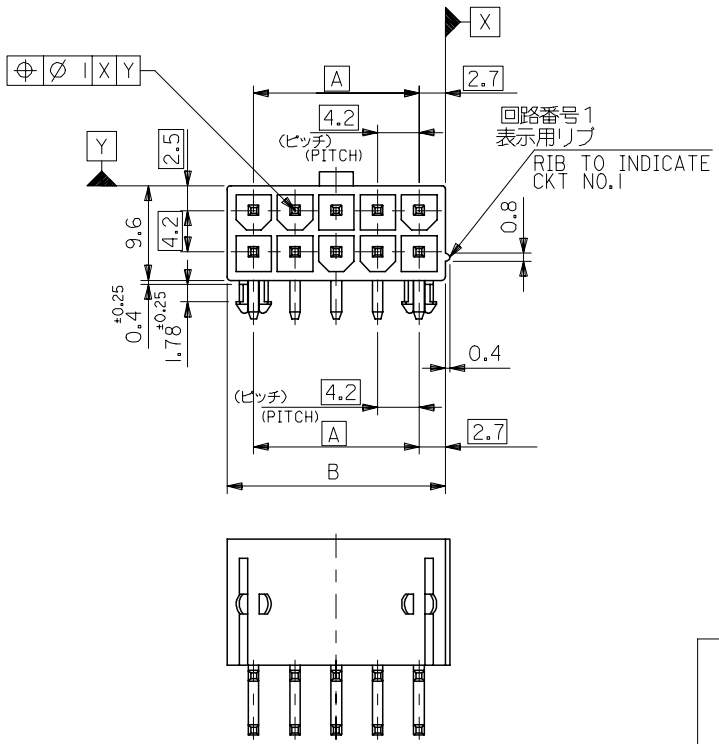
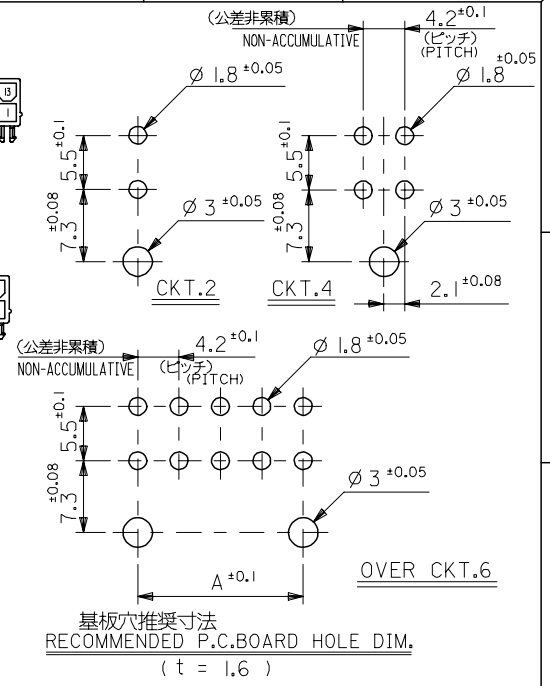

51.6	46.2	39-30-0240	5569-24A2-210	24
47.4	42.0	39-30-0220	5569-22A2-210	22
43.2	37.8	39-30-0200	5569-20A2-210	20
39.0	33.6	39-30-0180	5569-18A2-210	18
34.8	29.4	39-30-0160	5569-16A2-210	16
30.6	25.2	39-30-0140	5569-14A2-210	14
26.4	21.0	39-30-0120	5569-12A2-210	12
22.2	16.8	39-30-0100	5569-10A2-210	10
18.0	12.6	39-30-0080	5569-08A2-210	8
13.8	8.4	39-30-0060	5569-06A2-210	6
9.6	4.2	39-30-0040	5569-04A2-210	4
5.4	—	39-30-0020	5569-02A2-210	2
B	A	EDP NO.	ENG. NO.	極数

- 注記  
NOTES
1. 嵌合相手: 5557-NR-210  
MATES WITH : 5557-NR-210
  2. 一般公差: ±0.38  
GENERAL TOLERANCE : ±0.38

材料  
MATERIAL    図中参照  
SEE DRAWING  
仕上げ  
FINISH    図中参照  
SEE DRAWING

RELEASED EC NO: J2007-1208 2006/10/27 DRW:KSAITO 2006/10/31 CHK:KTOYODA 2006/10/31 APPR:NUKITA 2006/10/31	GENERAL TOLERANCES (UNLESS SPECIFIED)	DIMENSION STYLE MM ONLY	SCALE 2:1	DESIGN UNITS METRIC	THIRD ANGLE PROJECTION
	10 UNDER ± ---	DRAWN BY K. SAITO	DATE 2006/10/24	TITLE MINI-FIT JR R/A HEADER ASSY WITH MOUNTING PEGS	
	10 OVER 30 UNDER ± ---	CHECKED BY K. TOYODA	DATE 2006/10/24	MOLEX INCORPORATED	
	30 OVER ± ---	APPROVED BY N. UKITA	DATE 2006/10/24	DOCUMENT NO. SD-5569-001	SHEET NO. 1 OF 1
ANGULAR ± --- °	DRAFT WHERE APPLICABLE MUST REMAIN WITHIN DIMENSIONS	SEE CHART	THIS DRAWING CONTAINS INFORMATION THAT IS PROPRIETARY TO MOLEX INCORPORATED AND SHOULD NOT BE USED WITHOUT WRITTEN PERMISSION		

**LEGEND:**

5569 - N A \* \* \* \*

BASE NUMBER

CIRCUIT SIZE

ASSEMBLY

MOUNTING OPTION (SEE NOTE 6.)

PLATING (SEE NOTE 2.)

HOUSING MAT'L. (SEE NOTE 1.)

CIRCUIT SIZE	DIM. "A"	DIM. "B"
6	.54 (13.8)	.33 (8.4)
8	.71 (18.0)	.50 (12.6)
10	.87 (22.2)	.66 (16.8)
12	1.04 (26.4)	.83 (21.0)
14	1.20 (30.6)	.99 (25.2)
16	1.37 (34.8)	1.16 (29.4)
18	1.54 (39.0)	1.32 (33.6)
20	1.70 (43.2)	1.49 (37.8)
22	1.87 (47.4)	1.65 (42.0)
24	2.03 (51.6)	1.82 (46.2)

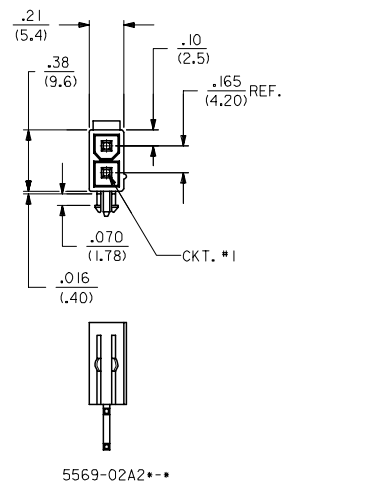
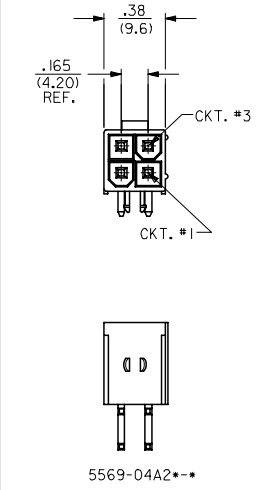
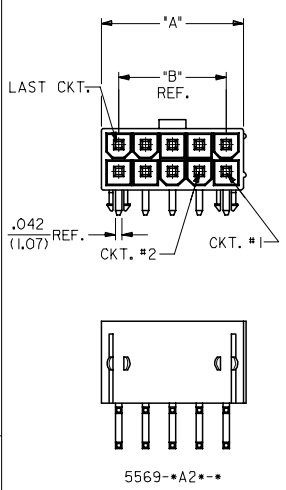
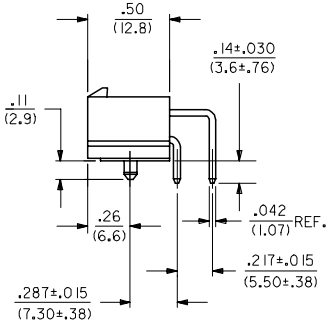

**NOTES:**

1) MATERIAL: HOUSING: "BLANK" = NYLON (PA66), UNFILLED, UL94V-2, COLOR: NATURAL "100" = NYLON (PA66), UNFILLED, UL94V-2, COLOR: BLACK "BL" = NYLON (PA66), UNFILLED, UL94V-2, COLOR: BLACK "210" = NYLON (PA66), UNFILLED, UL94V-0, COLOR: NATURAL "400" = NYLON (PA66), UNFILLED, UL94V-0, COLOR: BLACK

TERMINAL: BRASS ALLOY

2) FINISH (PLATING): "A" = .000200/(0.00508) MIN. BRIGHT TIN OVER .000100/(0.00254) MIN. COPPER "G" = .000030/(0.00076) MIN. GOLD OVER .000050/(0.00127) MIN. NICKEL "G2" = .000015/(0.00038) MIN. GOLD OVER .000030/(0.00076) MIN. NICKEL "G3" = .000050/(0.00127) MIN. GOLD OVER .000050/(0.00127) MIN. NICKEL "GS" = .000030/(0.00076) MIN. SELECT GOLD OVER .000100/(0.00254) MIN. SELECT MATTE TIN OVER .000050/(0.00127) MIN. NICKEL OVERALL "GS2" = .000015/(0.00038) MIN. SELECT GOLD OVER .000100/(0.00254) MIN. SELECT MATTE TIN OVER .000050/(0.00127) MIN. NICKEL OVERALL "GS3" = .000050/(0.00127) MIN. SELECT GOLD OVER .000100/(0.00254) MIN. SELECT MATTE TIN OVER .000050/(0.00127) MIN. NICKEL OVERALL "S" = .000100/(0.00254) MIN. BRIGHT TIN OVER .000050/(0.00127) MIN. NICKEL

\*THE PRIMARY SHIPPING CARTON WILL BE LABELED "COMPLIANT TO RoHS DIRECTIVE 2002/95/EC AND ELV ANNEX II OF DIRECTIVE 2000/53/EC"; CARTONS WITHOUT THIS LABEL MAY CONTAIN PRODUCT WITH TIN-LEAD PLATING.

3) PRODUCT SPECIFICATION: SHOWN IN CHART AT RIGHT

4) PACKAGING: BULK

5) PART MATES WITH MINI-FIT JR. RECEPTACLE SERIES 5557.

6) MOUNTING OPTIONS:  
1 = SCREW MOUNT (SEE SD-5569-NA\* SERIES DRAWING)  
2 = PEG MOUNT

7) DISCOLORATION IN THE BANDOLIER CARRIER AREA OF THE PIN IS INHERENT TO THE PLATING PROCESS AND IS DUE TO THE MASKING EFFECT OF THE CARRIER. THIS DISCOLORATION IS IN A NON-FUNCTIONAL AREA OF THE PIN AND WILL NOT AFFECT THE PERFORMANCE OF THE HEADER ASSEMBLY.

8) PART CONFORMS TO CLASS "B" REQUIREMENTS OF COSMETIC SPECIFICATION PS-45499-002.

9) CONNECTORS ARE NOT TO BE MATED AND UNMATED WHILE CIRCUITS ARE LIVE.

10) PARTS ARE NOT DESIGNED FOR CURRENT SHARING.

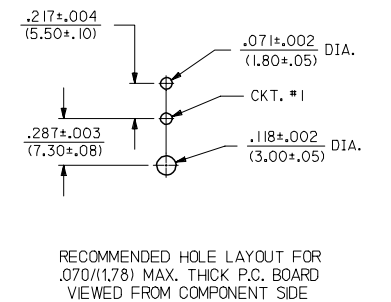
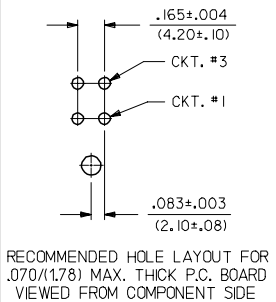
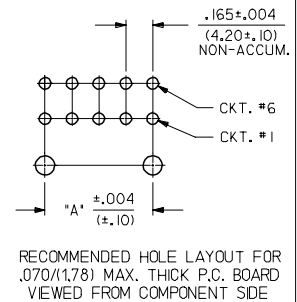

5569-A2S-BL	PS-5556-001
5569-A2G3-BL	PS-5556-001
5569-A2G2-BL	PS-5556-001
5569-A2G-BL	PS-5556-001
5569-A2-BL	PS-5556-001
5569-A2G3 & A2G3-210	PS-5556-001
5569-A2S & A2S-210	PS-5556-001
5569-A2GS3 & A2GS3-210	PS-5556-001
5569-A2GS2 & A2GS2-210	PS-5556-001
5569-A2GS & A2GS-210	PS-5556-001
5569-A2G2 & A2G2-210	PS-5556-001
5569-A2G & A2G-210	PS-5556-001
5569-A2 & A2-210	PS-5556-001

5	K1
4	K1
3	K1
2	K1
1	K3

ENG. NO. PROD. SPEC. NO.

PRODUCT SPEC. CHART

<p><b>UPDATED NOTES</b></p> <p>EC NO: UCP2007-0664</p> <p>DRW:WLSCHM1D 2006/09/22</p> <p>CHKD: 2006/09/25</p> <p>APPR:FSM TH 2006/09/26</p> <p>REV: K3</p>	<p>QUALITY SYMBOLS</p> <p>▽=0</p> <p>▽=0</p>	<p>GENERAL TOLERANCES (UNLESS SPECIFIED)</p> <table border="1"> <thead> <tr> <th></th> <th>mm</th> <th>INCH</th> </tr> </thead> <tbody> <tr> <td>4 PLACES</td> <td>± .10</td> <td>± .004</td> </tr> <tr> <td>3 PLACES</td> <td>± .15</td> <td>± .010</td> </tr> <tr> <td>2 PLACES</td> <td>± .25</td> <td>± .015</td> </tr> <tr> <td>1 PLACE</td> <td>± .38</td> <td>± .015</td> </tr> </tbody> </table> <p>ANGULAR ±1/2°</p>		mm	INCH	4 PLACES	± .10	± .004	3 PLACES	± .15	± .010	2 PLACES	± .25	± .015	1 PLACE	± .38	± .015	<p>DIMENSION STYLE</p> <p>IN/MM</p>	<p>DRAWN BY</p> <p>RJF</p> <p>DATE</p> <p>02/16/88</p>	<p>SCALE</p> <p>1:1</p>	<p>DESIGN UNITS</p> <p>METRIC</p>	<p>THIRD ANGLE PROJECTION</p>
				mm	INCH																	
			4 PLACES	± .10	± .004																	
			3 PLACES	± .15	± .010																	
2 PLACES	± .25	± .015																				
1 PLACE	± .38	± .015																				
<p>DRAFT WHERE APPLICABLE MUST REMAIN WITHIN DIMENSIONS</p>	<p>SEE CHART</p>	<p>MATERIAL NO.</p> <p>SDA-5569-NA2*-*</p>	<p>DOCUMENT NO.</p> <p>1 OF 5</p>																			
<p>THIS DRAWING CONTAINS INFORMATION THAT IS PROPRIETARY TO MOLEX INCORPORATED AND SHOULD NOT BE USED WITHOUT WRITTEN PERMISSION</p>																						
<p>MINI-FIT JR RIGHT ANGLE HEADER ASSEMBLIES WITH MOUNTING PEGS</p> <p>MOLEX MOLEX INCORPORATED</p>																						

SEE SHEET ONE  
EC NO: UCP2005-1130  
DRAWN: STEWART 2004/12/04  
CHKD: GPOLGAR 2004/12/09  
APPR: YMARGULLI 2004/12/13

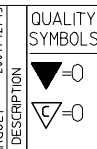

GENERAL TOLERANCES (UNLESS SPECIFIED)	
mm	INCH
4 PLACES ± .005	± .0002
3 PLACES ± .005	± .0002
2 PLACES ± .005	± .0002
1 PLACE ± .005	± .0002
ANGULAR ±1/2°	

DIMENSION STYLE	
IN/MM	
DRAWN BY	DATE
RJF	08/16/88
CHECKED BY	DATE
JTR	08/16/88
APPROVED BY	DATE
RAS	08/16/88
MATERIAL NO.	DOCUMENT NO.
SDA-5569-NA2*-*	SDA-5569-NA2*-*

SCALE 1:1  
DESIGN UNITS INCH  
THIRD ANGLE PROJECTION  
MINI-FIT JR. RIGHT ANGLE HEADER ASSEMBLIES WITH MOUNTING PEGS  
MOLEX INCORPORATED  
SHEET NO. 2 OF 5  
THIS DRAWING CONTAINS INFORMATION THAT IS PROPRIETARY TO MOLEX INCORPORATED AND SHOULD NOT BE USED WITHOUT WRITTEN PERMISSION

PART NUMBER	ENG. NUMBER	CKT. SIZE	MTG. OPTION	PLATING (NOTE 6)	HSG. MAT'L.
39-30-1020	5569-02A2	2	PEGS	TIN OVER COPPER	94V-2
↑ -1040	↑ -04A2	4	↑	↑	↑
↑ -1060	↑ -06A2	6	↑	↑	↑
↑ -1080	↑ -08A2	8	↑	↑	↑
↑ -1100	↑ -10A2	10	↑	↑	↑
↑ -1120	↑ -12A2	12	↑	↑	↑
↑ -1140	↑ -14A2	14	↑	↑	↑
↑ -1160	↑ -16A2	16	↑	↑	↑
↑ -1180	↑ -18A2	18	↑	↑	↑
↑ -1200	↑ -20A2	20	↑	↑	↑
↑ -1220	↑ -22A2	22	↑	↑	↑
39-30-1240	5569-24A2	24	PEGS	TIN OVER COPPER	94V-2
39-30-1021	5569-02A2G	2	PEGS	30 M.I. GOLD	94V-2
↑ -1041	↑ -04A2G	4	↑	↑	↑
↑ -1061	↑ -06A2G	6	↑	↑	↑
↑ -1081	↑ -08A2G	8	↑	↑	↑
↑ -1101	↑ -10A2G	10	↑	↑	↑
↑ -1121	↑ -12A2G	12	↑	↑	↑
↑ -1141	↑ -14A2G	14	↑	↑	↑
↑ -1161	↑ -16A2G	16	↑	↑	↑
↑ -1181	↑ -18A2G	18	↑	↑	↑
↑ -1201	↑ -20A2G	20	↑	↑	↑
↑ -1221	↑ -22A2G	22	↑	↑	↑
39-30-1241	5569-24A2G	24	PEGS	30 M.I. GOLD	94V-2
39-30-0021	5569-02A2G2	2	PEGS	15 M.I. GOLD	94V-2
↑ -0041	↑ -04A2G2	4	↑	↑	↑
↑ -0061	↑ -06A2G2	6	↑	↑	↑
↑ -0081	↑ -08A2G2	8	↑	↑	↑
↑ -0101	↑ -10A2G2	10	↑	↑	↑
↑ -0121	↑ -12A2G2	12	↑	↑	↑
↑ -0141	↑ -14A2G2	14	↑	↑	↑
↑ -0161	↑ -16A2G2	16	↑	↑	↑
↑ -0181	↑ -18A2G2	18	↑	↑	↑
↑ -0201	↑ -20A2G2	20	↑	↑	↑
↑ -0221	↑ -22A2G2	22	↑	↑	↑
39-30-0241	5569-24A2G2	24	PEGS	15 M.I. GOLD	94V-2
NOT TOOLED	5569-02A2G3	2	PEGS	50 M.I. GOLD	94V-2
↑ -1514	↑ -04A2G3	4	↑	↑	↑
↑ -1511	↑ -06A2G3	6	↑	↑	↑
↑ -1512	↑ -08A2G3	8	↑	↑	↑
↑ -1503	↑ -10A2G3	10	↑	↑	↑
NOT TOOLED	↑ -12A2G3	12	↑	↑	↑
NOT TOOLED	↑ -14A2G3	14	↑	↑	↑
↑ -1513	↑ -16A2G3	16	↑	↑	↑
NOT TOOLED	↑ -18A2G3	18	↑	↑	↑
↑	↑ -20A2G3	20	↑	↑	↑
↑	↑ -22A2G3	22	↑	↑	↑
NOT TOOLED	5569-24A2G3	24	PEGS	50 M.I. GOLD	94V-2

13 12 11 10 9 8 7 6 5 4 3 2 1

J I H G F E D C B A