

Distributed by:

JAMECO[®]
ELECTRONICS

www.Jameco.com ♦ 1-800-831-4242

The content and copyrights of the attached
material are the property of its owner.

Jameco Part Number 883579

FEATURES AND SPECIFICATIONS

Features and Benefits

- "Offset Terminal Retention" for optimum retention to PC board during wave soldering
- Fully polarized to mating receptacle
- Peg feature provides polarization to PCB
- Surface Mount Compatible

Reference Information

Product Specification: PS-43045

Packaging: Tray

UL File No.: E29179

CSA File No.: LR19980

TUV License No.: R95107

Mates With: [43025](#)

Designed In: Millimeters

Electrical

Voltage: 250V

Current: 5.0A max.

Contact Resistance: 10mΩ max.

Dielectric Withstanding Voltage: 1500V AC

Insulation Resistance: 1000 MΩ min.

Mechanical

Insertion Force to PCB: 7.5kgf max. (16.5 lb)

Physical

Housing: High temperature LCP, UL 94V-0

Contact: Brass

Plating: Tin or Gold



3.00mm (.118") Pitch Micro-Fit 3.0™ Wire-to-Board Header

43045 Dual Row Vertical

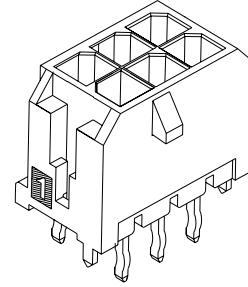

CATALOG DRAWING (FOR REFERENCE ONLY)

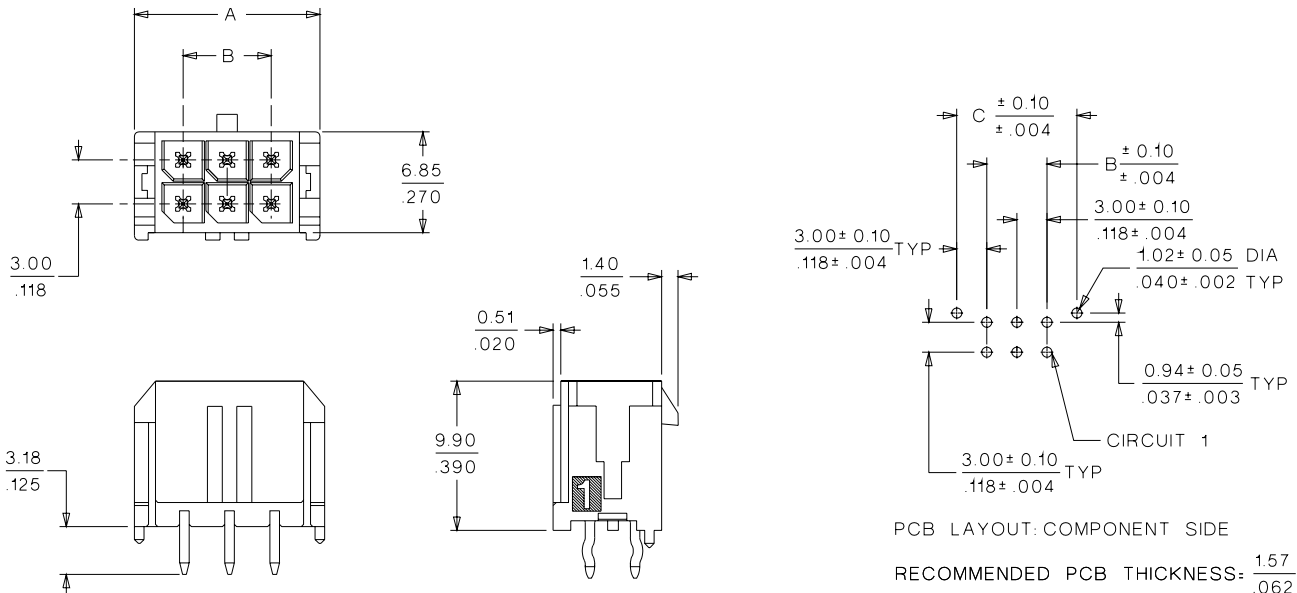

ORDERING INFORMATION AND DIMENSIONS

Circuits	Order No.						Dimension		
	Standard "OTR" Version			Straight Tail Version			A	B	C
	Tin	15μ" Gold	30μ" Gold	Tin	15μ" Gold	30μ" Gold			
2	• 43045-0212	• 43045-0213	• 43045-0214	43045-0227	43045-0228	43045-0229	6.65 (.262)	6.00 (.236)	6.00 (.236)
4	• 43045-0412	• 43045-0413	• 43045-0414	43045-0427	43045-0428	43045-0429	9.65 (.380)	3.00 (.118)	9.00 (.354)
6	• 43045-0612	• 43045-0613	• 43045-0614	43045-0627	43045-0628	43045-0629	12.65 (.498)	6.00 (.236)	12.00 (.472)
8	• 43045-0812	• 43045-0813	• 43045-0814	43045-0827	43045-0828	43045-0829	15.65 (.616)	9.00 (.354)	15.00 (.591)
10	• 43045-1012	• 43045-1013	• 43045-1014	43045-1027	43045-1028	43045-1029	18.65 (.734)	12.00 (.472)	18.00 (.709)
12	• 43045-1212	• 43045-1213	• 43045-1214	43045-1227	43045-1228	43045-1229	21.65 (.852)	15.00 (.591)	21.00 (.827)
14	• 43045-1412	• 43045-1413	• 43045-1414	43045-1427	43045-1428	43045-1429	24.65 (.970)	18.00 (.709)	24.00 (.945)
16	• 43045-1612	• 43045-1613	• 43045-1614	43045-1627	43045-1628	43045-1629	27.65 (1.088)	21.00 (.827)	27.00 (1.063)
18	• 43045-1812	• 43045-1813	• 43045-1814	43045-1827	43045-1828	43045-1829	30.65 (1.206)	24.00 (.945)	30.00 (1.181)
20	• 43045-2012	• 43045-2013	• 43045-2014	43045-2027	43045-2028	43045-2029	33.65 (1.325)	27.00 (1.063)	33.00 (1.299)
22	• 43045-2212	• 43045-2213	• 43045-2214	43045-2227	43045-2228	43045-2229	36.65 (1.443)	30.00 (1.181)	36.00 (1.417)
24	• 43045-2412	• 43045-2413	• 43045-2414	43045-2427	43045-2428	43045-2429	39.65 (1.561)	33.00 (1.299)	39.00 (1.535)

• US Standard Product, available through Molex franchised distributors



PRODUCT SPECIFICATION

MICRO-FIT

1.0 SCOPE

This Product Specification covers the 3.00 mm (.118 inch) centerline (pitch) square pin headers when mated with either printed circuit board (PCB) connector or connectors terminated with 20 to 30 AWG wire using crimp technology.

2.0 PRODUCT DESCRIPTION

2.1 PRODUCT NAME AND SERIES NUMBERS

Receptacle: 43025 Terminal: 43030
Plug: 43020 Terminal: 43031
Headers: 43045, 44914

Test Plug: 44242 (recommended for continuity testing only)

Other products conforming to this specification are noted on the individual drawings.

2.2 DIMENSIONS, MATERIALS, PLATINGS AND MARKINGS

Housings: Polyester or LCP
Terminal: Phosphor Bronze
Pins: Brass, Modified Tin/Brass

2.3 SAFETY AGENCY APPROVALS

UL File Number: E29179
CSA: LR19980
TUV: 72040445

3.0 APPLICABLE DOCUMENTS AND SPECIFICATIONS

Test Summary: TS-43045-001

4.0 RATINGS

4.1 VOLTAGE

UL: 250 Volts AC (MAX) {or 176 Volts DC}
TUV: 250 Volts

4.2 CURRENT AND APPLICABLE WIRES (Current is dependent on connector size, contact material, plating, ambient temperature, printed circuit board characteristics and related factors. Actual current rating is application dependent and should be evaluated for each application.)

AWG	Amps	Max. Outside Insulation Diameter
20	5	1.85 mm (.073 inch)
22	5	1.85 mm (.073 inch)
24	4	1.85 mm (.073 inch)
26	3	1.27 mm (.050 inch)
28	2	1.27 mm (.050 inch)
30	1	1.27 mm (.050 inch)

4.2.1 CURRENT FOR TEST PLUG 44242

2.5 Amps Maximum (Pogo pin current capacity)

(Test plugs are for testing purposes only and not intended for continuous use.)

4.3 TEMPERATURE

Operating: - 40°C to + 105°C (Including Terminal Temperature Rise)
Nonoperating: - 40°C to + 105°

REVISION: L	EGR/ECN INFORMATION: EC No: UCP2007-1024 DATE: 2006/10/24	TITLE: PRODUCT SPECIFICATION MICRO-FIT DUAL ROW CONNECTORS	SHEET No. 1 of 5
DOCUMENT NUMBER: PS-43045		CREATED / REVISED BY: M.KIPPER	CHECKED BY: S.SOUSEK
		APPROVED BY: F.SMITH	



PRODUCT SPECIFICATION

5.0 PERFORMANCE

5.1 ELECTRICAL REQUIREMENTS

DESCRIPTION	TEST CONDITION	REQUIREMENT
Contact Resistance (Low Level)	Mate connectors: apply a maximum voltage of 20 mV and a current of 100 mA. (Does not include wire resistance)	10 milliohms MAXIMUM [initial]
Contact Resistance @ Rated Current	Mate connectors: apply a maximum voltage of 20 mV at rated current.	30 milliohms MAXIMUM [initial]
Contact Resistance of Wire Termination (Low Level)	Terminate the applicable wire to the terminal and measure wire using a voltage of 20 mV and a current of 100 mA.	5 milliohms MAXIMUM [initial]
Insulation Resistance	Unmate & unmount connectors: apply a voltage of 500 VDC between adjacent terminals and between terminals to ground.	1000 Megohms MINIMUM
Dielectric Withstanding Voltage	Unmate connectors: apply a voltage of {two times the rated voltage plus 1000 volts} VAC for 1 minute between adjacent terminals and between terminals to ground.	No breakdown; current leakage < 5 mA
Capacitance	Measure between adjacent terminals at 1 MHz.	2 picofarads MAXIMUM
Temperature Rise (via Current Cycling)	Mate connectors: measure the temperature rise at the rated current after: 1) 96 hours (steady state) 2) 240 hours (45 minutes ON and 15 minutes OFF per hour) 3) 96 hours (steady state)	Temperature rise: +30°C MAXIMUM

5.2 MECHANICAL REQUIREMENTS

DESCRIPTION	TEST CONDITION	REQUIREMENT
Connector Mate and Unmate Forces	Mate and unmate connector (male to female) at a rate of 25 ± 6 mm (1 ± ¼ inch) per minute. (Per circuit)	8.0 N (1.8 lbf) MAXIMUM insertion force & 3.7 N (0.8 lbf) MINIMUM withdrawal force
Terminal Retention Force (in Housing)	Axial pullout force on the terminal in the housing at a rate of 25 ± 6 mm (1 ± ¼ inch) per minute.	24.5 N (5.5 lbf) MINIMUM retention force
Terminal Insertion Force (into Housing)	Apply an axial insertion force on the terminal at a rate of 25 ± 6 mm (1 ± ¼ inch) per minute.	14.7 N (3.3 lbf) MAXIMUM insertion force

REVISION: L	EGR/ECN INFORMATION: EC No: UCP2007-1024 DATE: 2006/10/24	TITLE: PRODUCT SPECIFICATION MICRO-FIT DUAL ROW CONNECTORS	SHEET No. 2 of 5
DOCUMENT NUMBER: PS-43045	CREATED / REVISED BY: M.KIPPER	CHECKED BY: S.SOUSEK	APPROVED BY: F.SMITH



PRODUCT SPECIFICATION

5.2 MECHANICAL REQUIREMENTS

Durability	Mate connectors up to 30 cycles at a maximum rate of 10 cycles per minute prior to Environmental Tests.	20 milliohms MAXIMUM (change from initial)
Vibration (Random)	Mate connectors and vibrate per EIA 364-28, test condition VII.	20 milliohms MAXIMUM (change from initial) & Discontinuity < 1 microsecond
Shock (Mechanical)	Mate connectors and shock at 50 g's with ½ sine wave (11 milliseconds) shocks in the ±X,±Y,±Z axes (18 shocks total).	20 milliohms MAXIMUM (change from initial) & Discontinuity < 1 microsecond
Wire Pullout Force (Axial) (Wire from Terminal)	Apply an axial pullout force on the wire at a rate of 25 ± 6 mm (1 ± ¼ inch) per minute.	MINIMUM pullout force 20 awg: 57.8 N (13.0 lbf) 22 awg: 35.6 N (8.0 lbf) 24 awg: 22.2 N (5.0 lbf) 26 awg: 13.3 N (3.0 lbf) 28 awg: 8.9 N (2.0 lbf) 30 awg: 6.6 N (1.5 lbf)
Normal Force	Apply a perpendicular force.	2.7 N (275 grams) MINIMUM
Pin to Header Retention	Apply axial push force to pin at a rate of 25 ± 6 mm (1 ± ¼ inch) per minute.	13.7 N (3.1 lbf) MINIMUM pushout force
Thumb Latch to Ramp Yield Strength	Full mate and then Unmate the connectors at a rate of 25 ± 6 mm (1 ± ¼ inch) per minute.	68.4 N (15.4 lbf) MINIMUM Yield Strength
Panel Mount Retention	Full mate and then Unmate the connectors at a rate of 25 ± 6 mm (1 ± ¼ inch) per minute.	155.7 N (35 lbf) MINIMUM pushout force
Compliant Pin Insertion Force into PCB Hole (44914 Series)	Apply an axial insertion force on the terminal at a rate of 25 ± 6 mm (1 ± ¼ inch) per minute.	106.7 N (24 lbf) MAXIMUM Insertion force (Per Terminal)
Compliant Pin Retention Force in PCB Hole (44914 Series)	Apply an axial extraction force on the terminal at a rate of 25 ± 6 mm (1 ± ¼ inch) per minute.	35.6 N (8 lbf) MINIMUM Retention force (Per Terminal)

REVISION: L	EGR/ECN INFORMATION: EC No: UCP2007-1024 DATE: 2006/10/24	TITLE: PRODUCT SPECIFICATION MICRO-FIT DUAL ROW CONNECTORS	SHEET No. 3 of 5
DOCUMENT NUMBER: PS-43045	CREATED / REVISED BY: M.KIPPER	CHECKED BY: S.SOUSEK	APPROVED BY: F.SMITH



PRODUCT SPECIFICATION

5.3 ENVIRONMENTAL REQUIREMENTS

DESCRIPTION	TEST CONDITION	REQUIREMENT
Thermal Aging	Mate connectors; expose to: 240 hours at 105 ± 2°C OR 500 hours at 85 ± 2°C	20 milliohms MAXIMUM (change from initial)]
Humidity (Steady State)	Mate connectors: expose to a temperature of 40 ± 2°C with a relative humidity of 90-95% for 96 hours. Note: Remove surface moisture and air dry for 1 hour prior to measurements.	20 milliohms MAXIMUM (change from initial) & Dielectric Withstanding Voltage: No Breakdown at 500 VAC & Insulation Resistance: 1000 Megohms MINIMUM
Solderability	Per SMES-152	Solder coverage: 95% MINIMUM (per SMES-152)
Solder Resistance	A) Wave Solder Process Dip connector terminal tails in solder; Solder Duration: 5 ± 0.5 seconds; Solder Temperature: 260°C MAX B) Convection Reflow Solder Process 235°C MAX Per SMES-152	Visual: No Damage to insulator material
Cold Resistance	Mate connectors: Duration: 96 hours; Temperature: -40 ± 3°C	20 milliohms MAXIMUM (change from initial)

6.0 PACKAGING

Parts shall be packaged to protect against damage during handling, transit and storage per the packaging specifications listed below:

Receptacle: PK-43025-001

Plug: PK-43020-001

Headers: PK-70873-0313, PK-70873-0314, PK-70873-05**.

REVISION: L	EGR/ECN INFORMATION: EC No: UCP2007-1024 DATE: 2006/10/24	TITLE: PRODUCT SPECIFICATION MICRO-FIT DUAL ROW CONNECTORS	SHEET No. 4 of 5
DOCUMENT NUMBER: PS-43045	CREATED / REVISED BY: M.KIPPER	CHECKED BY: S.SOUSEK	APPROVED BY: F.SMITH



PRODUCT SPECIFICATION

7.0 GAGES AND FIXTURES

It is recommended that test plugs (Series 44242) be used for continuity testing of receptacles. Standard mating parts should not be used for harness testing.

8.0 OTHER INFORMATION

8.1 CABLE TIE AND OR WIRE TWIST LOCATION

CKT Sizes	Dim T	Min.
2-8	.500	(12.70)
10-16	.750	(19.10)
18-24	1.000	(25.40)

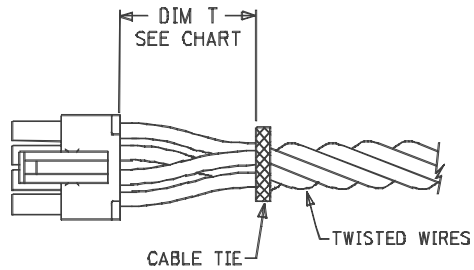

REVISION: L	EGR/ECN INFORMATION: EC No: UCP2007-1024 DATE: 2006/10/24	TITLE: PRODUCT SPECIFICATION MICRO-FIT DUAL ROW CONNECTORS	SHEET No. 5 of 5
DOCUMENT NUMBER: PS-43045	CREATED / REVISED BY: M.KIPPER	CHECKED BY: S.SOUSEK	APPROVED BY: F.SMITH

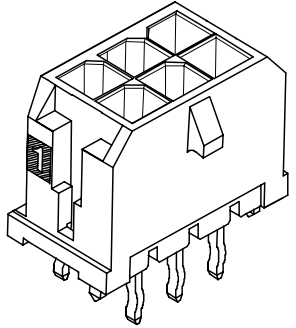
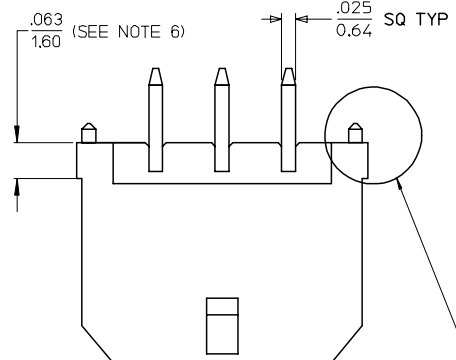

NOTE : (2) POLARIZATION PEGS ARE SHOWN. HOWEVER, ASSEMBLIES MAY BE MANUFACTURED WITH (1) PEG ONLY.

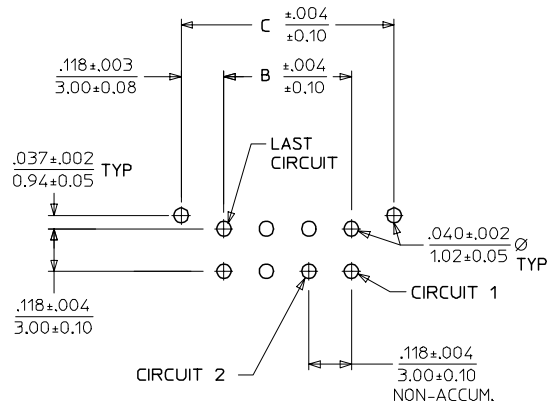

PCB LAYOUT: COMPONENT SIDE
RECOMMEND PCB THICKNESS: .062/1.57

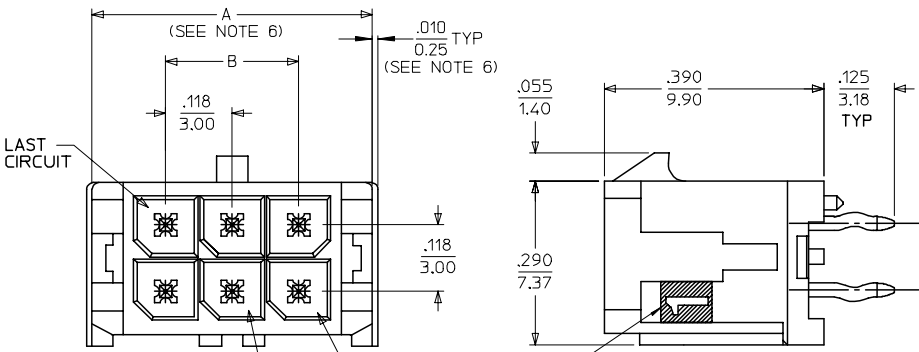

CKTS	A (SEE NOTE 6)	B	C
02	.262 6.65	NA	.236 6.00
04	.380 9.65	.118 3.00	.354 9.00
06	.498 12.65	.236 6.00	.472 12.00
08	.616 15.65	.354 9.00	.591 15.00
10	.734 18.65	.472 12.00	.709 18.00
12	.852 21.65	.591 15.00	.827 21.00
14	.970 24.65	.709 18.00	.945 24.00
16	1.088 27.65	.827 21.00	1.063 27.00
18	1.206 30.65	.945 24.00	1.181 30.00
20	1.325 33.65	1.063 27.00	1.299 33.00
22	1.443 36.65	1.181 30.00	1.417 36.00
24	1.561 39.65	1.299 33.00	1.535 39.00

NOTES:

- HOUSING MATERIAL: GLASS FILLED LIQUID CRYSTAL POLYMER, UL94V-0, COLOR: BLACK
TERMINAL MATERIAL: BRASS ALLOY
- FINISH:
A = .000100/(0.00254) MIN. TIN OVER
.000050/(0.00127) MIN. NICKEL PLATE.
B = .000015/(0.00038) MIN. SELECT GOLD IN CONTACT AREA,
.000100/(0.00254) MIN. SELECT MATTE TIN ON SOLDER TAILS,
BOTH OVER .000050/(0.00127) MIN. NICKEL PLATE.
C = .000030/(0.00076) MIN. SELECT GOLD IN CONTACT AREA,
.000100/(0.00254) MIN. SELECT MATTE TIN ON SOLDER TAILS,
BOTH OVER .000050/(0.00127) MIN. NICKEL PLATE.
* THE PRIMARY SHIPPING CARTON WILL BE LABELED *COMPLIANT TO
RoHS DIRECTIVE 2002/95/EC AND ELV ANNEX II OF DIRECTIVE 2000/53/EC.*
CARTONS WITHOUT THIS LABEL MAY CONTAIN PRODUCT WITH TIN/LEAD
IN THE PC TAIL AREA.
- PRODUCT SPECIFICATION: PS-43045
- MATES WITH MICRO FIT (3,0) RECEPTACLE SERIES 43025
- TRAY PACKAGED: SEE MOLEX DRAWING PK-70873-0314
- PARTS MANUFACTURED AFTER 2007/02/28 MAY HAVE ADDITIONAL .010/0.25
OFFSETS AS INDICATED. THE PRIMARY SHIPPING CARTON LABEL WILL CONTAIN
A GREEN DOT TO IDENTIFY THESE PARTS.

CIRCUIT "1" IDENTIFIED ON THIS SURFACE
(APPROX. LOCATION SHOWN FOR REF.)

	FINISH A	FINISH B	FINISH C
CKTS	MATERIAL NO:	MATERIAL NO:	MATERIAL NO:
02	43045-0212	43045-0213	43045-0214
04	43045-0412	43045-0413	43045-0414
06	43045-0612	43045-0613	43045-0614
08	43045-0812	43045-0813	43045-0814
10	43045-1012	43045-1013	43045-1014
12	43045-1212	43045-1213	43045-1214
14	43045-1412	43045-1413	43045-1414
16	43045-1612	43045-1613	43045-1614
18	43045-1812	43045-1813	43045-1814
20	43045-2012	43045-2013	43045-2014
22	43045-2212	43045-2213	43045-2214
24	43045-2412	43045-2413	43045-2414

ADD OFFSET/NOTE 6 EC NO: UCP2007-1883 DRAWN:MKL/PER 2007/03/05 CHKD:SSOUSEK 2007/03/05 APPR:FSM/TH 2007/03/05 REVISION DESCRIPTION	QUALITY SYMBOLS	GENERAL TOLERANCES (UNLESS SPECIFIED)	DIMENSION STYLE	SCALE	DESIGN UNITS	THIRD ANGLE PROJECTION
	▽=0 ▽=0	mm INCH 4 PLACES ± --- ± --- 3 PLACES ± --- ± .010 2 PLACES ± 0.25 ± .014 1 PLACE ± 0.36 ± --- ANGULAR ±1/2°	IN/MM	---	METRIC	MICRO FIT (3,0) DUAL ROW VERTICAL THRU HOLE HEADER ASS'Y
	DRAWN BY: SAMIEC CHECKED BY: MUELLER APPROVED BY: EDGLEY	DATE: 2000/03/15 DATE: 2000/03/15 DATE: 2000/03/15	TITLE			MOLEX INCORPORATED DOCUMENT NO. SD-43045-005
	DRAFT WHERE APPLICABLE MUST REMAIN WITHIN DIMENSIONS	SEE CHART	MATERIAL NO. SHEET NO. 1 OF 1	THIS DRAWING CONTAINS INFORMATION THAT IS PROPRIETARY TO MOLEX INCORPORATED AND SHOULD NOT BE USED WITHOUT WRITTEN PERMISSION		